

WINDSHIELD INFO

DODGE POWER GIANT & TOWN WAGON 1955-1966

The windshields are still available, in both "tinted", and "shaded" (same as tinted, plus a 5 inch dark green band across the top). Our trucks were originally equipped with "clear" (no tinting or shade whatsoever), however, that version has been discontinued.

PPG part: # DW425GTN (tinted) - Retail list: \$525.45

PPG part: # DW425GBN (tinted & shaded) - Retail \$525.45

Can be purchased for about \$225.00 by any auto glass company or body shop.

The correct windshield gasket (rubber), is also available still.

Made by "Precision Rubber Products Inc.", and it is top quality!

GASKET: Pt# WCR D425 - Retail list: \$63.29 Jobber= less 25%

It fits perfectly, has the correct moulded lower corners, and the correct groove for the lock-strip insert.

The lock-strip comes in black rubber, 5/16" round (as original).

Or mylar chrome, approx. 5/8" wide (flat).

BLACK LOCK-STRIP: pt. # WLS900 - \$11.75 ea.

CHROME Lock-strip: # WLS913/914 - \$28.85ea.

If you would like my professional opinion, (26+yrs) I would offer the following recommendations:

1. Don't waste your money on any other gasket, from any other manufacturer! You'll pay about the same or more \$, and what you'll get is universal, incorrect, ill-fitting, pourous, leaking, non-uv protected, dry-rot in a year, worthless garbage!! Period!

2. If you choose to use the chrome mylar lock-strip, be aware that it will begin to dull and deteriorate after two or three years of exposure to the elements. Just look at any '73-'87 gm truck, or pre '90's bmw 3 series car, that hasn't been covered or garaged for all or most of its life, and you will see it's brown and crispy.

3. Again, with regard to the lock-strip, both the black and the chrome will shrink some over time, creating an ever-widening gap. To combat this shrinkage, be sure to cut the lock-strip about an inch or so longer, overlapping the point where the two ends will meet, or "seam" together, in the middle at the bottom of the windshield. Then, using a sharp blade, cut each end cleanly & squarely to make the most invisible seam possible. Only trim a tiny sliver at a time off each end until you are satisfied with the appearance of your seam. Then you can force the overlapping extra inch or so down into the groove causing the two ends to push tightly together. As time goes by any shrinkage of the lock-strip will be offset by the extra inch of length that was squeezed into the groove, and the seam will stay tight instead of wanting to pull apart making an ugly gap.

Or, you can obtain a chrome coupling clip from any '70-'91 dodge full size van, to hide the seam completely, which is how the factory solved the problem of the unsightly gap. The connector is about an inch long, and simply hid the ever-widening end gaps until they had shrunk up enough that the connector clip fell, or blew off somewhere on the highway or the jet-wash.

All civilian style (conventional cab) Dodge trucks used the DW425 windshield, beginning with the 1955 "C-3" (second series) that debuted on April 11, 1955, As did the "D" 100-800's, and the "W" 100-500's up through '60 for the pick-ups and larger trucks with regular cabs (the rear wall & rear window directly behind the bench seat).

A new body style began for 1961, and uses a DW605 from '61-'71. The Town Wagons & Town Panels retained the DW425 until the end of their production run in the fall of '66. The DW425 windshield continued in use in the largest Dodge trucks, such as the diesel and gas powered semi-tractors, such as "C" SERIES 500-1000's, "CT" 800-1000's, "CN" 800-1000's, "CNT" 909090T 900-1000 tandems, and finally the last of the Dodge heavy duty haulers, the infamous "BIGHORN", which finally became extinct in 1975!

Larry Bissillon

DODGE TOWN WAGON SIDE WINDOW INSTALLATION TIPS

1. First it is recommended that these windows be installed by someone experienced. These tips are offered only as a general guide. The side windows are removed from the body by removing the inside trim screws. There are also small channel plugs at each end of the channel held by sheet metal screws that should be removed. The rear most window section seal is pryed or pulled up and out. Next the window frame is pushed in at the top rear, with the forward glass retaining rubber pryed up and away from the body. Usually this rubber is destroyed in the process.
2. Hopefully now that the frame is out, the glass can be removed. The frame must be pulled up slightly to remove the glass. The frame has notches to make this process easier. The pieces of glass will need to be slid or worked towards the center to get them out. Use caution in working with the glass; the original glass should be tempered and is expensive to replace.
3. The flexible channel is attached by staples and can usually be pulled out with some effort. It helps to grind, cut or file the "exposed" side of the staples at the frame. All remains of the staples must be removed. All rust should be removed and the frames refinished.
4. Before window installation the body channel should have all rust removed, treated and finished. The drain tube fittings and end plugs need to be carefully sealed to divert water into the drain tubes. The rubber tubes should be replaced and attached with hose clamps.
5. Cut and install the inner flexible channel (1/2"x3/8" Metro WC-12) with the joint at the top. Use trim or weatherstrip adhesive in lieu of trying to staple thru the steel frame. Note the drain hole locations in the steel frame. The flexible channel should have holes carefully punched to align with the frame to allow drainage.
6. The vertical sweep channel is removed from the glass by carefully prying or tapping it off. Carefully pry the dented down sections of the metal sweep channel up and remove the old strip by pulling it out lengthwise. De-rust and refinish metal channel. Slide in new sweep strip (7/16"x15/64" Metro WC-8) and pinch down as original to hold in place. Install onto glass using new setting tape (1/6") as required.
7. The glass is installed in roughly the opposite order of its removal. Lubricate the forward channel, slip over the glass, pull up on the frame and work the glass & rubber into the frame. Carefully install the sliding glass section with the vertical sweep installed, noting the position of the "latch". Push the frame down, seat the glass and check the rubber margin around the frame. Trim off excess ends of rubber. Place the window unit into the body channel bottom first, slide forward, working rubber over body with top going in last. Lubricate and push in the rear rubber; trim ends to tightly butt the forward rubber.

Don Evans, 8/96

NOTE: The side window weather seal is not available from any manufacturer. It has been custom extruded by Don Evans which is where I got mine from and Michael Yerxa has had it done before and sold some sets. michael.yerxa@gmail.com

VINTAGE POWER WAGONS, INC.

641 472 4665

888 695 0578 TO ORDER

dodge@vintagepowerwagons.com



NEW 1957-60 POWER GIANT WEATHERSTRIP NOW IN STOCK!

(Includes 1957-66
Town Wagon &
Town Panel)

CC1561523 Vertical DoorWindow Rigid Division Channel pair \$30

CC1561228 Upper Flexible Door Window Channel pair \$35

CC6013060 Upper Channel Clip set of 6 \$6

CC1561229 *Outer Door Glass Sweep w/ 8 clips pair \$20

*(some 59 and later models require 4 door glass sweeps, instead of pair)

CC1397502 Inner Door Glass Rubber Bumpers** set of 4 \$16

** (not required on models using 4 Door Glass Sweeps)

CC1563649 Town Wagon Side Window Glass End Channel set of 4 \$8

CC1563650/1 Town Wagon Side Window Glass Run set of 4 \$72

CC1397425 Town Wagon/Panel Rear Door Window weatherseal

includes CC1304227 Rear Lockstrip pair \$25

CC1560898/9 Town Wagon/Panel Rear Door Weatherstrip pair \$48

CC1397083 Cowl Vent Weatherstrip \$10

CC1561565 Windshield Weatherstrip includes CC1547222

Lockstrip \$60

CC6010155 Front Hood Bumpers 58 & up pair \$8

CC1199902 Rear Hood Bumpers 58 & up pair \$12

CC1624079 Side Hood Bumpers 58 & up set of 6 \$18

Complete Set of Hood Bumpers \$25

COMING SOON! DODGE POWER GIANT

molded door weatherstrip, lower door weatherstrip,
transmission shifter boot and Town Wagon side
window weatherstrip.

Notes on Clesters, Precision and VPW rubber

Clesters Rubber products has the windshield gasket and the side window rubber.
They also carry the best door gaskets with the dogleg piece at the front of the doors.

Restoration Specialties has all the window channel and small rubber parts you'll need like the cowl vent rubber.
The one from VPW will NOT fit unless they changed it recently.

There currently is no vent window rubber but they are working on repopping them. Don't order the rear door weatherstripping from VPW it's generic and doesn't fit. Nothing against VPW I like those guys but I've found better suppliers for things. — Ron Reichart

Make sure you get the metal door window channel for TWs and Power Giants from VPW, as they sent me Sweptline era rubber ones — Gary Robertson

Windshield gasket made by Precision Rubber Products is the best according to Larry Bissillon, a glass professional. See full notes above.

DODGE TRUCKS

CLESTER'S RUBBER SEALS

CLESTERS AUTO RUBBER SEALS, P.O BOX 1113, SALISBURY, NC 28144 1-800-457-8223

WINDSHIELD CHANNELS

PART NUMBER	YEAR(S)	DESCRIPTION	PRICE
8230-WS	48-53	WINDSHIELD CHANNEL	\$65.00
8211-12-WS5	55-60	PICK UP WITH LOCKSTRIP	\$65.00
8211-12-WS5	55-64	CAB MODEL 5712, 5722, 5732, C-40, D40, D41, W40, RD-40, RC-41, RKC-41, RNC-41, RD-20	\$65.00
8211-12-WS5	55-66	TOWN PANEL/TOWN WAGON	\$65.00
8211-12-WS5	57-70	LOWER CAB FORWARD	\$65.00
8211-12	61-71	FULL SIZE WITH LOCKSTRIP	\$65.00

REAR GLASS CHANNELS

PART NUMBER	YEAR(S)	DESCRIPTION	PRICE
8317	40-48	PLYMOUTH ONLY UTILITY	\$49.00
8217-RW	48-53	REAR WINDOW CHANNEL	\$40.00
8217-C	48-53	REAR CORNER (2 PCS.)	\$40.00
8211-12-RW5	55-64	LARGE REAR WINDOW W/LOCKSTRIP	\$55.00
8036-7-D-384	55-66	TOWN PANEL REAR WINDOW SEAL W/LOCKSTRIP (2 PCS.)	\$48.00
8036-7-D-384	57-66	TOWN WAGON REAR WINDOW SEAL W/LOCKSTRIP (2 PCS.)	\$48.00
8211-12-RW5	57-70	LOWER CAB FORWARD REAR WINDOW	\$55.00
8216-12-RW	61-67	SMALL REAR WINDOW W/LOCKSTRIP	\$35.00
8211-12-RW	61-71	LARGE REAR WINDOW W/LOCKSTRIP	\$55.00

8319-20-SK SIDE WINDOW WEATHER-STRIPPING??

DOOR WEATHERSTRIPPING

PART NUMBER	YEAR(S)	DESCRIPTION	PRICE
8225-6-7	48-53	DOOR SEAL KIT (6 PCS.)	\$63.00ST
8198	61-70	ALL FULL SIZE TRUCKS	\$59.00PR
8198-R	61-70	REAR DOOR SEAL CREW CAB MODELS	\$59.00PR
8192-315	72-74	FULL SIZE TRUCKS	\$59.00PR
D-100	73-81	DOOR WINDOWFELT (SET)	\$39.00PR
8299-315	75-76	FULL SIZE TRUCKS	\$59.00PR
8194-315	78-93	ALL FULL SIZE TRUCKS	\$63.00PR

SLIDER REAR WINDOWS

PART NUMBER	YEAR(S)	DESCRIPTION	PRICE
721-SW	61-71	REAR SLIDER/CLEAR	\$85.00
722-SW	72-75	REAR SLIDER/CLEAR	\$85.00

MISCELLANEOUS RUBBER SEALS

PART NUMBER	YEAR(S)	DESCRIPTION	PRICE
8228-316	48-53	BODY-TO-FENDER	\$15.00PR
8231-310	61-71	BODY-TO-BUMPER	\$29.00

PART NUMBERS

DODGE POWER GIANT & TOWN WAGON WINDOWS AND SEALS

ITEM	YEAR	MANUF / SUPPLIER	PART NO.	SIZE	QUAN	PRICE
WINDSHIELD	55-66	PPG (BISSAILLON GLASS, FW, TX)	DW425GTN (TINTED) (\$225.00 WHOLESale)			\$525.45
WINDSHIELD	55-66	PPG (BISSAILLON GLASS, FW, TX)	DW425GBN (TINTED & SHADED) (\$225.00 WHOLESale)			\$525.45
WINDSHIELD GASKET	55-66	PRECISION RUBBER PRODUCTS	WCR D425 (25% LESS / JOBBER)			\$63.29
WINDSHIELD BLACK LOCK-STRIP	55-66	PRECISION RUBBER PRODUCTS	WLS900			\$11.75
WINDSHIELD CHROME LOCK-STRIP	55-66	PRECISION RUBBER PRODUCTS	WLS913/914			\$28.85
WINDSHIELD SEAL		JC WHITNEY	81-2538R STYLE 9	16FT	1	\$22.46
WINDSHIELD LOCK		JC WHITNEY	81-2568W	16FT	1	\$6.74
WINDSHIELD WHEATHERSTRIP (W LOCKSTRIP)		VINTAGE POWER WAGONS	CC1561565		1	\$60.00
WINDSHIELD WIPERS (ENTIRE UNIT)		ANCO DEAD LOCKER	R/N05325	12"		NA
WIPER ARMS		ANCO 41-02				
WIPER BLADES		ANCO 20-12				
KEYS W/CYLINDER LOCKS		MITCHELL MOTOR PARTS 614-875-4919	1785142 (2 DOORS AND IGNITION)			NA
		MITCHELL MOTOR PARTS	1785143 (3 DOORS AND IGNITION)			NA
KEY BLANKS DOOR		ILCO	1125F; 1125H H5; 1766DT PENTAGON HEAD			NA
PAUL HAMMERSCHMIDT restopaul@verizon.net		ILCO	1766DT PENTAGON HEAD, MIGHT HAVE A BOX			
KEY BLANKS		JECO	H4			NA
KEY BLANKS DOOR		STAR	HFD2			NA
DOOR WINDOW CHANNEL (TOP AND REAR FLEXIBLE)		JC WHITNEY	19-3468N STEEL CORE	6FT 9/16 X 9/16 X 3/16	2	12.79
DOOR WINDOW CHANNEL (TOP AND REAR FLEXIBLE)		VINTAGE POWER WAGONS	CC1561228 PAIR		1	35.00
UPPER CHANNEL CLIP SET OF 6		VINTAGE POWER WAGONS	CC6013060			6.00
CLIPS FOR FLEXIBLE WINDOW CHANNEL		RESTORATIONSPECIALTIES.COM	2489			
DOOR WINDOW CHANNEL (FRONT RIDGID)		JC WHITNEY	19-3473N STEEL CORE	6FT 1/2 X 1/2 X 3/16+	1	16.99
DOOR WINDOW CHANNEL (FRONT RIDGID)		VINTAGE POWER WAGONS	CC1561523 PAIR		1	30.00
REAR SIDE WINDOW CHANNEL		STANDARD / LOCAL AUTO GLASS	5P.			
REAR SIDE WINDOW CHANNEL		METRO	WC-12	1/2 X 3/8		NA
REAR SIDE WINDOW CHANNEL		JC WHITNEY (33+FT REQ)	19-3463W STEEL CORE	6FT 1/2 X 3/8 X 1/8	6	11.69
WEATHER STRIP DOORS FRT (EXCEPT ELBOW)		JC WHITNEY (W/GLUE)	81-8769U	14FT	2	11.99
FRONT DOOR SILL BOTTOM (FROG HAIR)		JC WHITNEY (NO CLIPS)	19-3481Y	6FT 17/64 X 9/16	2	8.99
FRONT DOOR SILL BOTTOM (FROG HAIR) 59 AND UP		VINTAGE POWER WAGONS (W 8 CLIPS)	CC1561229 PAIR		2	20.00
SIDE WINDOW VERT. END CHANNEL SWEEP		VINTAGE POWER WAGONS (SET OF 4)	CC1563649		1	8.00
SIDE WINDOW VERT. END CHANNEL SWEEP		METRO	WC-8	7/16 X 15/64	4	NA
SIDE WINDOW VERT. SLIDER SWEEPS		RESTORATIONSPECIALTIES.COM	YM3 NEED TO PULL BEADING OFF ONE SIDE			
SIDE WINDOW END CHANNEL GLASS RUN		VINTAGE POWER WAGONS (SET OF 4)	CC1563650/1		1	72.00
REAR DOOR WINDOW WHEATHERSEAL (W LOCKSTRIP)		VINTAGE POWER WAGONS	CC1397425 PAIR		1	25.00
REAR DOOR WHEATHERSTRIP		VINTAGE POWER WAGONS	CC1560898/9 PAIR		1	48.00
COWL VENT WEATHERSTRIP		VINTAGE POWER WAGONS	CC1397083		1	10.00
HOOD BUMPERS (COMPLETE SET)		VINTAGE POWER WAGONS	CC1624079		1	25.00

CONTACT INFO FOR PARTS AND SUPPLIES

DAVE CIRILLO	jobrated@wave.net					
CLESTERS AUTO RUBBER SEALS		P.O BOX 1113, SALISBURY, NC 28144				800-457-8223
DODGE TRUCK ASSOC. HEADERS	moparnorm@hotmail.com	http://www.t137.com/dtapoly/addpoly.php				
ERIC'S DODGE TRUCK PARTS	townwagon@yahoo.com	http://stores.ebay.com/Erics-Classic-Dodge-Truck-Parts?refid=store				
KANTER AUTO PRODUCTS		www.kanter.com	ENGINE PARTS			973-334-9575, 800-526-1096
MID-SOUTH AUTO SALES			61-71 DODGE TRUCKS			910-768-6251
MITCHELL MOTOR PARTS		http://www.mmpar.com				614-875-4919
POWER WAGON ADVERTISER	B1PW1948@earthlink.net	www.powerwagonadvertiser.com/index.html				
POWER WAGON JOHN	cjapham@yahoo.com	http://imageevent.com/pwjohn	REPRO ITEMS			
POWER WAGONS PLUS	den@powerwagonparts.com		DENNIS SHERMAN			508-624-7485
POWER WAGON POSTERS	robertsondesign@mesanetworks.net	http://www.flickr.com/photos/31394972@N07/				
PRECISION RUBBER PRODUCTS	info@precisionpartsusa.com	http://www.precisionpartsusa.com/rubberparts.htm				714 961 2720, 916 412 8339
RESTORATION SPECIALTIES	info@restorationspecialties.com	restorationspecialties.com, P. O. Box 328, Windber, PA 15963				814-467-9842, 814-467-9282
ROBERTS MOTOR PARTS						508-363-5407
ROCK AUTO		www.rockauto.com				
STEER-N-GEAR			MOPAR STEERING GEARS			800-253-4327
SUMMIT RACING						800-230-3030
VALLEY VINTAGE AUTO PARTS			MOPAR PARTS			216-355-4085
VINTAGE POWER WAGONS	dodge@vintagepowerwagons.com	vintagepowerwagons.com				641-472-4665, 888-695-0578

DODGE TRUCK

POWER GIANT & TOWN WAGON WINDOW DIAGRAM 1955-1966

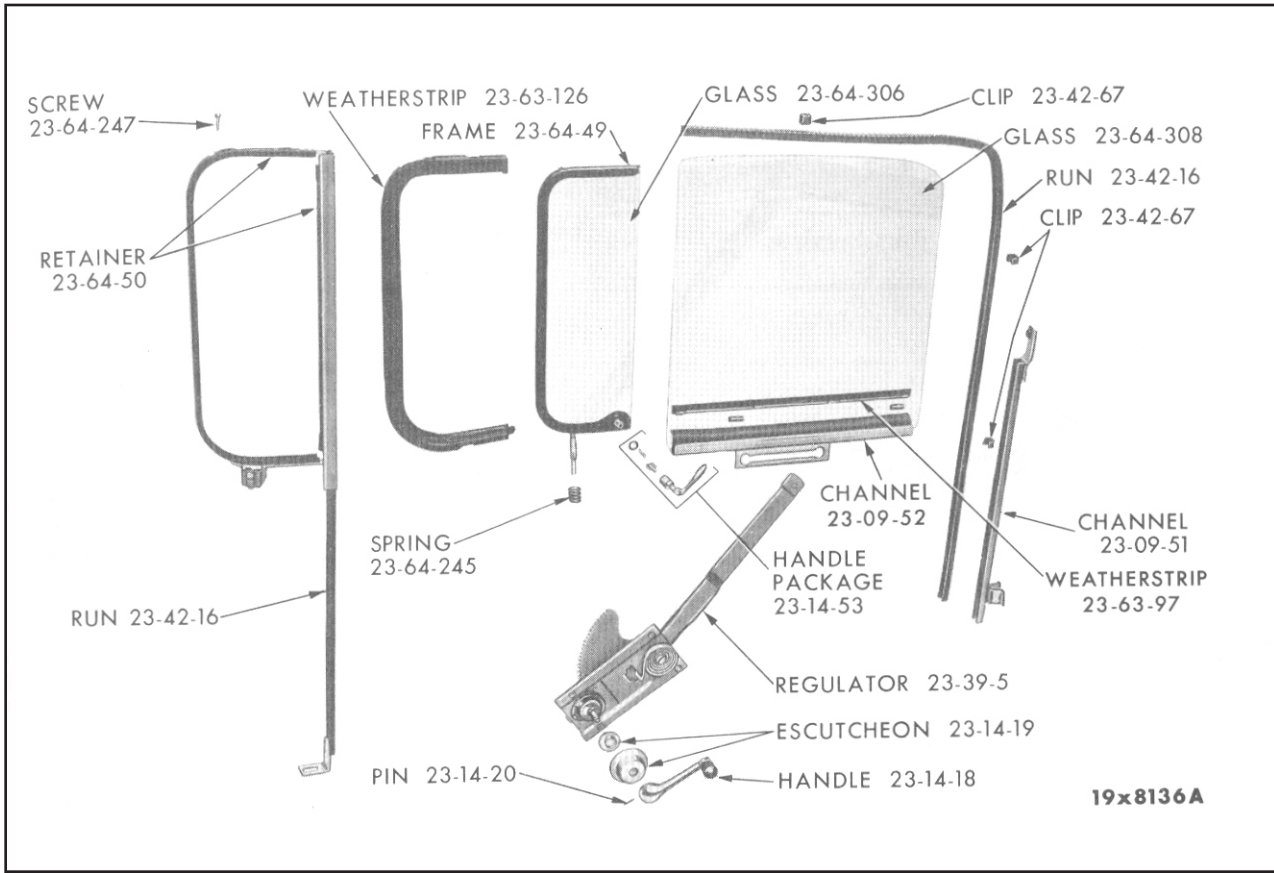

TOWN WAGON

SLIDER WINDOW KNOB 1954-1966

