

About Semroc Astronautics Corporation

Semroc Astronautics Corporation was started by Carl McLawhorn in his college dorm at North Carolina State University in November, 1967. Convincing a small group of investors in his home town of Ayden, North Carolina to invest in a small corporation, the company was re-incorporated as Semroc Astronautics Corporation on December 31, 1969.

Semroc produced a full line of model rocket kits and motors. At its peak, Semroc had twenty-five full time employees working at two facilities. One was for research and development, printing, shipping, and administration. The other was outside of town and handled all production and model rocket motor manufacturing. For several years, Semroc successfully sold model rocket kits, supplies, and motors by mail-order and in hobby shops. In early 1971, Semroc became insolvent and had to close its doors.

After 31 years of dreams and preparations, Semroc Astronautics Corporation was reincorporated on April 2, 2002 with a strong commitment to helping put the fun back into model rocketry. Many years of excellent service to the rocketry community passed by until sadly, on August 11 2013, Carl passed away and left a great void in the hearts of many rocketeers. He is forever in our hearts and minds.

In February of 2015, Semroc was sold to eRockets and moved to Dayton, Ohio where it resides today. It is our goal to continue the level of service and dedication to the hobby that Carl and his family were so well known for. We strive to serve you, our customers, to the best of our abilities as we carry the vision of Carl McLawhorn boldly into the future.

About the Semroc Mars Snooper™

The Mars Snooper was first offered by Estes in 1965. Production ran through 1974 with a special production run 18 years later as "Vintage Estes Collectors Series Mars Snooper" in 1992. Released as both kit number K-20 and as #2063, the Mars Snooper was one of the first exotic model rocket kits and was billed as being a great demo rocket.

This release of the Mars Snooper™ from Semroc features fiber fin alignment guides and other jigs to assist in the building process. We are proud to bring this wonderful Gene Street creation back to life again for modern model rocketeers and sincerely hope you enjoy building and flying this quality model rocket kit.

New instructions and jigs by Eric Specht.

November 2017

Copyright © 2017 Semroc
www.semroc.com

SEMROC

MARS SNOOPER™

1965 Retro Reproduction

Laser Cut Balsa Fins

Colorful Waterslide Decals

Precision Turned Balsa Nose Cones And Transition

18" Parachute Recovery



*Designed by:
Gene Street*

FLYING
MODEL
ROCKET KIT

Made in the U.S.A by Semroc - Dayton, Ohio

MARS SNOOPER™ Kit No. KV-92

Specifications	Engine	Approx. Altitude
Body Diameter	B6-2	190'
Length	C6-5	500'
Fin Span	D3-3	1180'
Net Weight	2.9 oz	

Skill Level 3

BEFORE YOU START!

Make sure you have all the parts included in this kit that are listed in the Parts List in these instructions. In addition to the parts included in this kit, you will also need the tools and materials listed below. Read the entire instructions before beginning to assemble your rocket. When you are thoroughly familiar with these instructions, begin construction. Read each step and study the accompanying drawings. Check off each step as it is completed. In each step, test-fit the parts together before applying any glue. It is sometimes necessary to sand lightly or build-up some parts to obtain a precision fit. If you are uncertain of the identity of some parts, refer to the exploded view. It is important that you always ensure that you have adequate glue joints.

TOOLS

In addition to the parts supplied, you will need the following tools to assemble and finish this kit.



ASSEMBLY

These instructions are presented in a logical order to help you assemble your Semroc Mars Snooper™ quickly and efficiently. Check off each step as you complete it. We hope you enjoy putting this kit together.

MOTOR MOUNT

- ❑ 1. Take coupler (G) and glue an adapter ring (F) to both ends. Do this by running a line of glue around the edge of the coupler and then pressing the ring into place. Wipe away any excess glue.

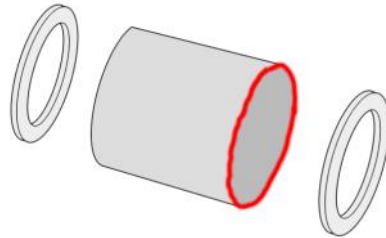

- ❑ 2. Glue the motor block (E) into the end of motor tube (D). Smear a line of glue inside the tube, then insert the motor block. Press the tube against the table until the block is even with the end of the tube.

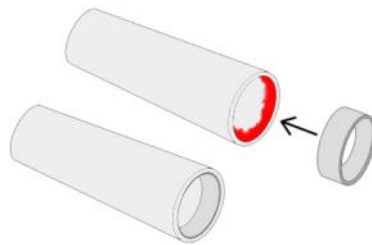

- ❑ 3. Make a mark on the motor mount tube 1 1/8 inches from the end with the motor block. Apply white glue around the motor tube inside of this mark as shown. Take the assembled coupler-adapter ring unit and slide it on until one ring is even with the 1 1/8 inch mark. Apply a fillet of glue around both joints. Wipe away any excess glue and set this assembly aside until the glue is dry.

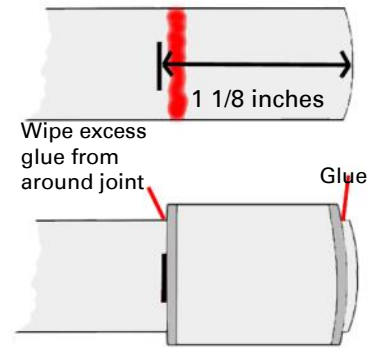

- ❑ 4. Run a line of glue around the motor mount tube where the red line indicates. Slide on the shroud ring (C) and seat it in the glue, making sure it is flush against the bottom ring of the adapter. Make a fillet of glue around the joint.

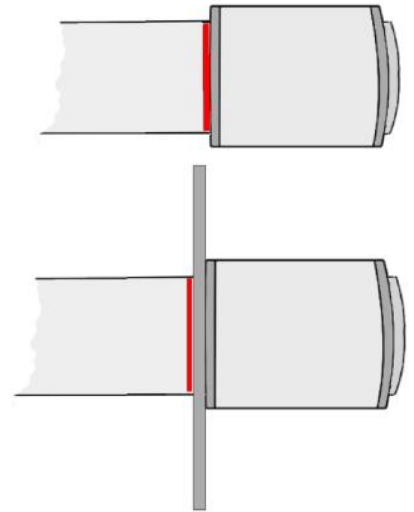

- ❑ 5. Locate the Kevlar anchor (H) Lightly notch the outside of the ring with a hobby knife or razor. Tie the Kevlar cord (Y) in a double knot around the ring so the Kevlar is in the notch. Run a bead of glue around the top of the motor mount. Slide on the notched centering ring with the attached Kevlar and press it gently into the glue. Wipe away any excess glue. Allow time to dry.

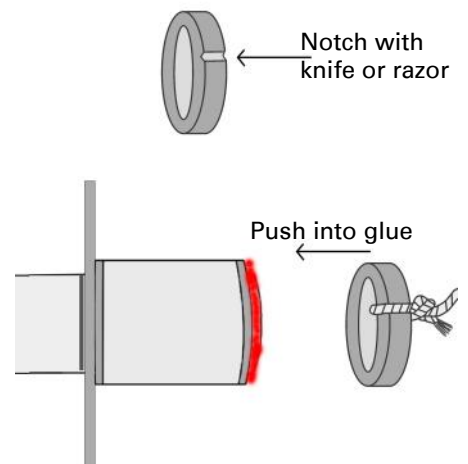

- ❑ **6.** Feed the Kevlar cord through the motor tube and out the bottom. Apply glue to the inside of the main airframe (I). Insert the motor mount assembly until the shroud ring is flush against the bottom of the tube.

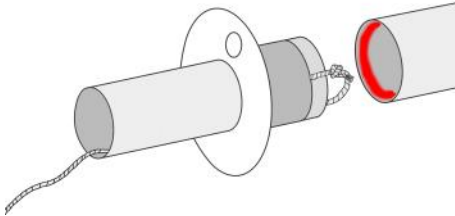

SHROUDS

- ❑ **7.** Locate the 3 shrouds. (A) Using a pencil and a straightedge, connect the lines as shown in the illustration. Avoid using too much pressure as you draw the lines. Too much pressure will weaken the shroud material and make it difficult to curl in the next step.

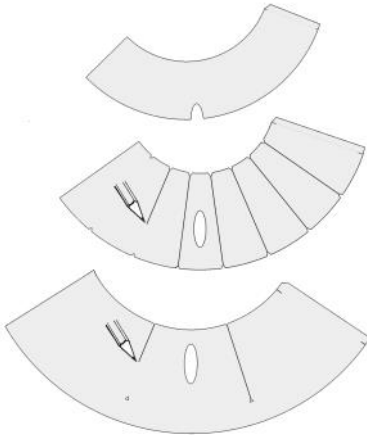

- ❑ **8.** Gently curl the shrouds over the edge of a table or a ruler. Take care to not bend or tear the shrouds, especially near the launch lug holes.

After the shrouds are curled, apply white glue to each tab as shown by the red lines. Line up the marks on the shrouds carefully and hold each one together tightly with either clamps or your fingers until the glue sets.

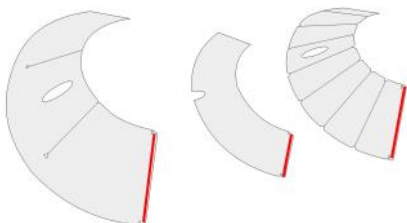

- ❑ **9.** Slide the top shroud (the one with two lines) over the top of the main airframe. Push it down the tube until it seats against the ring. Take note of the position of the shroud and slide it off of the ring.

Run a light line of glue around the main airframe tube and around the inside of the shroud where it contacts the ring. Push the shroud down the tube into the glue until it seats against the ring.

MAKE SURE THE LAUNCH LUG HOLE IN THE SHROUD LINES UP WITH THE HOLE IN THE RING.

Wipe away any excess glue.

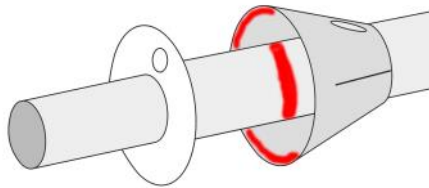

- ❑ **10.** Apply a thin line of glue around the inside of the centering ring and also around the motor mount tube. As before, make sure the holes for the launch lug line up, then slide the bottom shroud onto the motor mount tube into the glue. Wipe away any excess glue at both joints.

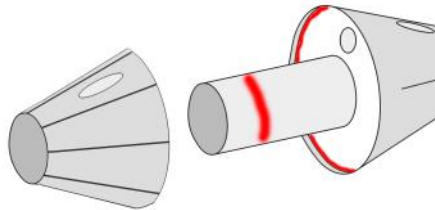

- ❑ **11.** Put a thin line of glue around the bottom of the motor mount tube. Push the nozzle shroud on into the glue. Make sure the notch in the nozzle lines up with the holes for the launch lug. Set assembly aside.

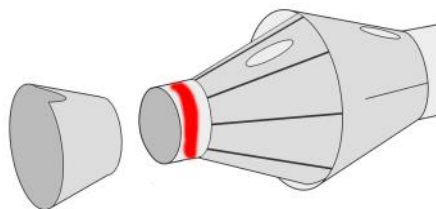

UPPER FINS

- ❑ **12.** Locate the 6 parts that make up the upper fins (Q). Lay a sheet of wax paper flat on the table. Using a straightedge to ensure alignment, apply white glue to the trailing edge of a strake and glue the two fin halves together. Repeat to make three fins.



- ❑ **13.** Slide the upper fin alignment jig (V) onto the top airframe tube. Position one 3/4 of an inch from the bottom and the other one 2 inches further up the tube. Make sure the bottoms of the jigs are resting on a perfectly flat surface.

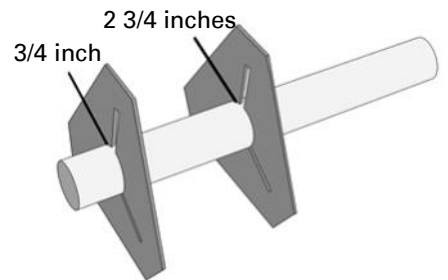

- ❑ **14.** Slide a completed fin into the upper fin alignment jig and tack in place with CA glue where indicated. Attach all three fins the same way. Avoid gluing the fin jigs to the airframe. When all three fins are tacked in place, remove the jigs.

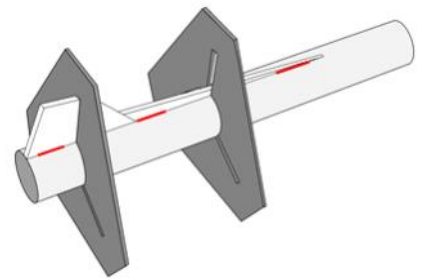

- ❑ **15.** Apply white glue fillets at the fin/airframe joint on both sides of all three fins.

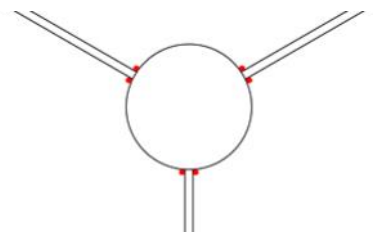

- ❑ 16. Install screw eye (O) into tube adapter (P) as shown. Remove, squirt in some glue and then replace the screw eye.

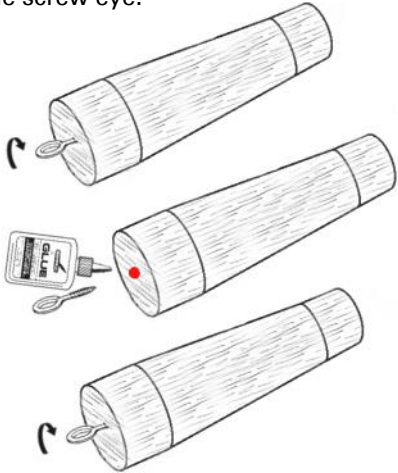

- ❑ 17. Apply a ring of glue around the inside of the upper airframe. Insert the small end of the tube adapter. Check to ensure the shoulder of the tube adapter is even with the bottom of the upper airframe.

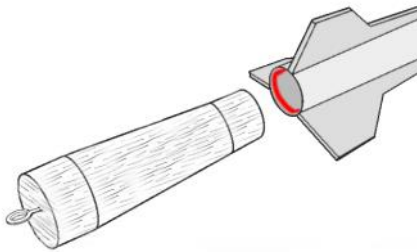

- ❑ 18. Glue the nose weight (S) to the bottom of the nose cone. If you do not plan to fly a payload then glue the nose cone in place as shown. Otherwise, use tape around the shoulder of the cone until it fits tightly into the upper airframe.

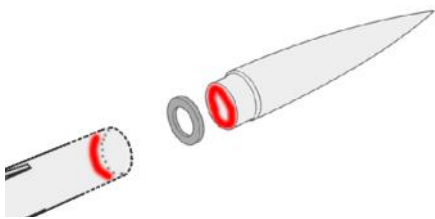

MAIN FINS

- ❑ 19. Take the three pod tubes (L) and make a mark 1/2 inch from the end of each tube. Glue the long nose cone (K) in place at the end opposite the mark you made. Glue the short nose cone (M) in place at the other end.

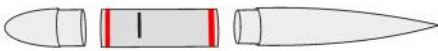

- ❑ 20. Assemble the pod fin jig (W).

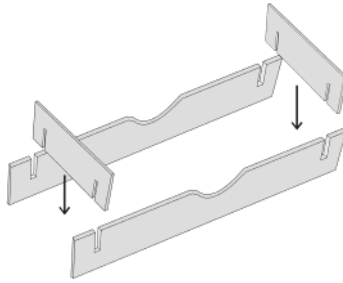

- ❑ 21. Gather the three sets of main fins (N). You may wish to round the leading and trailing edges at this time to make them more aerodynamic.

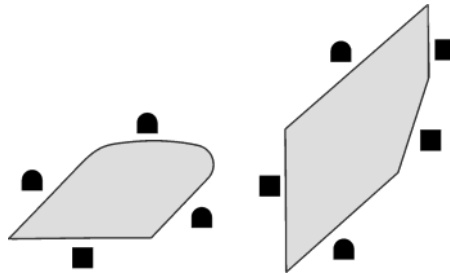

- ❑ 22. Lay a pod tube assembly on the pod fin jig so the mark is just a little below the bottom edge of the jig. Lay the outer fin flat on the jig and line the trailing edge up with the mark. Tack the outer fin in place with CA glue. Do the same for the inner fin. Repeat to make three fin/pod units.

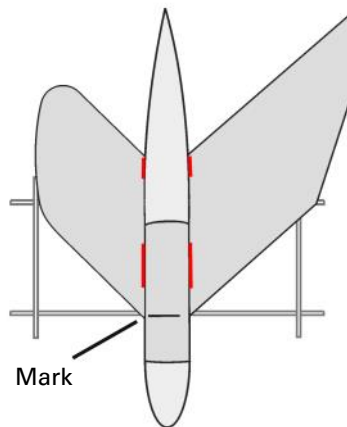

- ❑ 23. When all three pod units have fins tacked in place, apply fillets of white glue to all fin/pod joints.

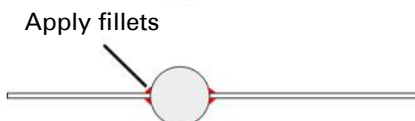

- ❑ 24. Apply white glue to the edges of a cooling fin (B) where shown and glue into place on a line. Work your way around the shroud until all cooling fins are attached.

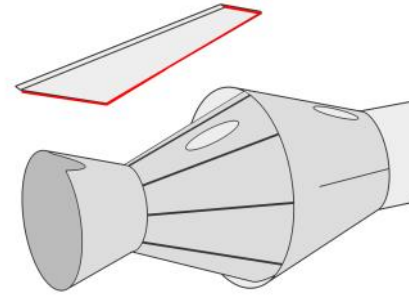

- ❑ 25. Insert the launch lug (J) into the shroud assembly until it is even with the bottom of the nozzle shroud. Glue into place as shown. After the glue sets, cut the launch lug to the angle of the top shroud with a sharp knife.

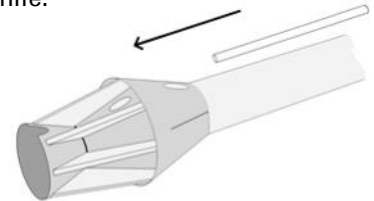

Cut lug to match shroud angle

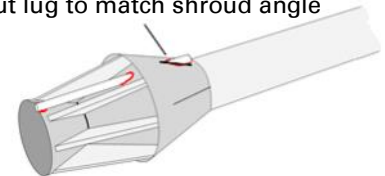

- ❑ 26. Glue each of the fin/pod assemblies to the shroud on the fin alignment lines. Use the main fin alignment jig (U) to check that each fin projects straight out from the airframe.

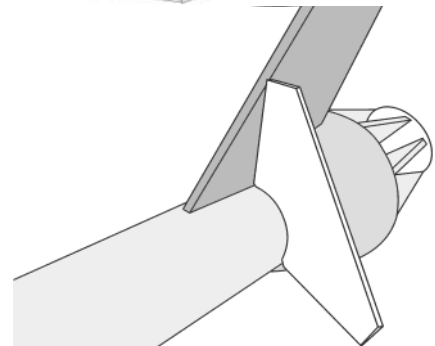
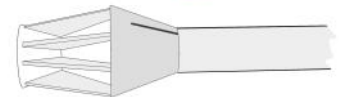
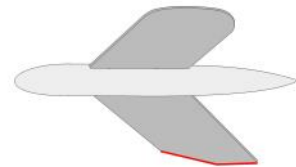

- ❑ 27. When the glue has dried on the main fins, apply white glue fillets at the fin/airframe joint on both sides of all three fins.

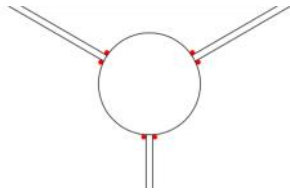

RECOVERY

- ❑ 28. Pass the Kevlar cord back through the motor mount and out the top of the airframe. Tie the Kevlar cord to the elastic shock cord (Z).

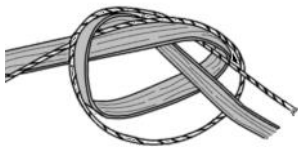

- ❑ 29. Tie the shock cord to the screw eye with a double overhand knot. Build the 18" parachute (X) according to the instructions with the chute. Tie the parachute to the screw eye. Set the knot with a drop of glue.

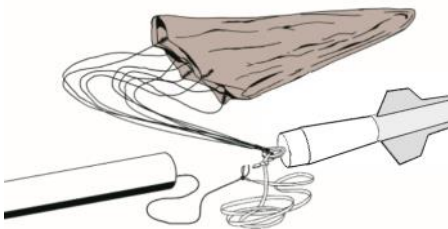

FINISHING

- ❑ 30. When all fillets have dried, prepare balsa surfaces for a smooth professional looking finish. Fill the wood grain with balsa fillercoat or sanding sealer. When dry, sand with fine sandpaper. Repeat until smooth.

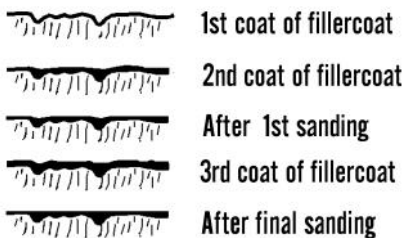

- ❑ 31. After the fins are primed and sanded smooth you may wish to fill in any spirals in the tube. Sand until smooth and apply 1 or 2 coats of sandable primer to finish.

- ❑ 32. Using a smooth and even motion, paint your Semroc Mars Snooper™ with a coat of gloss white spray paint.

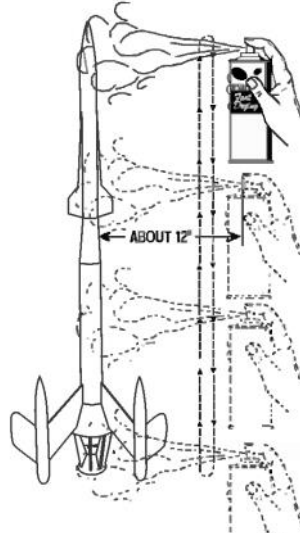

- ❑ 33. Cut out the three paint mask guides. Apply blue or green painter's tape to glass or a clean table. Tape the paint mask guides to the blue tape with cellophane tape. Using a straightedge, cut along the edges of the paint mask guides with a razor or hobby knife.

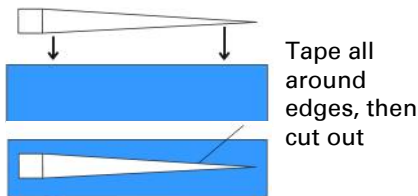

- ❑ 34. Align the tape guide between the upper fins as shown. Apply all 3 guides then spray paint blue.



- ❑ 35. Mask off everything shown in gray with painter's tape. Paint the bottom of your Mars Snooper™ Gloss black.

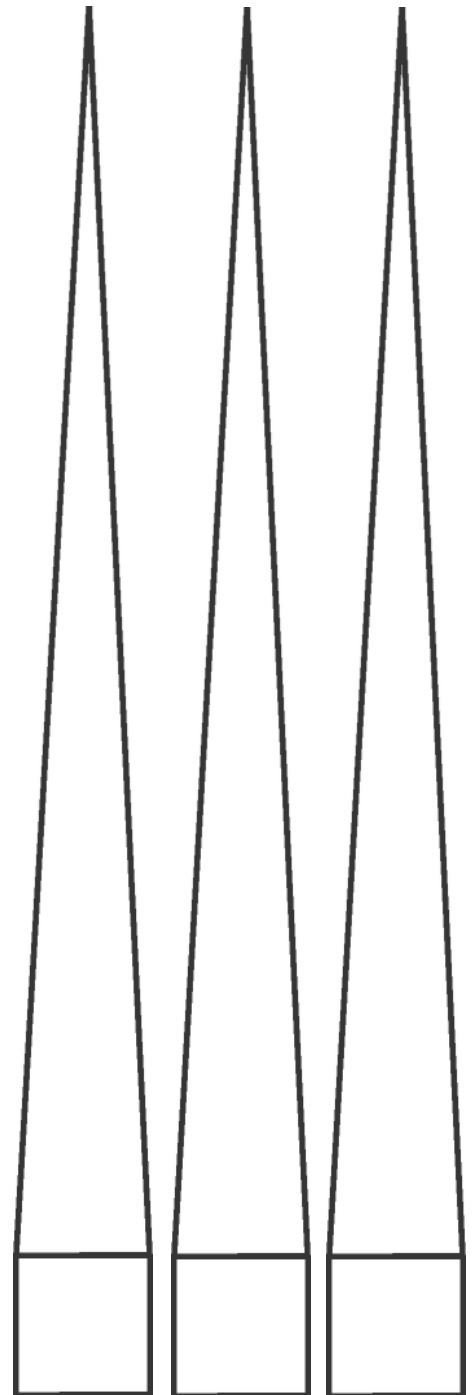
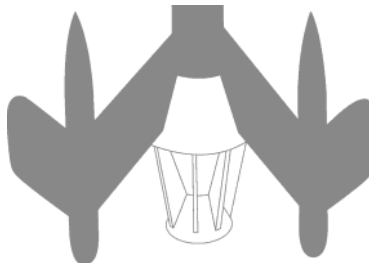

FLIGHT PREP

Select a motor from the list on the front of the instructions. Wrap a little masking tape around the middle of the motor. The motor must fit tightly, but not so tightly you damage the motor tube inserting it. Remove the top section. Place 4 or 5 loosely crumpled pieces of recovery wadding into the tube. Roll up the parachute and insert it, then replace the top section. Install the igniter per manufacturer instructions. Go out and LAUNCH!

