

SEMROC

Aerobee Hi

MODEL MISSILE KIT

1958 Retro
Reproduction
of the 1st Mass
Produced Rocket Kit

Semi-Scale
Sounding Rocket
Model

Laser Cut
Balsa Fins

Precision turned
Nose Cone

Water Slide
Decals

12"
Parachute
Recovery



FLYING MODEL
ROCKET KIT

Made in the U.S.A by Semroc - Dayton, Ohio

AEROBEE-HI

Kit No. KV-2

Specifications	Engine	Approx. Altitude
Body Diameter .825" (2.1 cm)	A8-5	350'
Length 14.0" (35.6 cm)	B6-6	750'
Fin Span 3.1" (8.0 cm)	C6-7	1400'
Net Weight 0.8 oz. (22.7 g)		

Skill Level 2

What is a Retro-Repro™?

A Retro-Repro is a retro reproduction of an out-of-production model rocket kit. It is a close approximation of a full scale model of an early historically significant model rocket kit from one of the many companies that pioneered the hobby over the past half century. A Retro-Repro is not a true clone or identical copy of the original. It incorporates improvements using modern technology, while keeping the flavor and build appeal of the early kits.

About Model Missiles, Inc.

Model Missiles, Inc. was founded by Orville H. Carlisle, G. Harry Stine, Willard L. Kauth and Donald Z. Kauth. The company was formed and incorporated in Denver, Colorado on October 7, 1957. The patented invention of Orville Carlisle called the "Rock-A-Chute" Safety-Proved Rocket Motor would provide the power for the early models.

The first production rocket kit was a scale model of the Aerobee-Hi to distance the models from their fireworks infancy. The first production model was produced on April 14, 1958 and is now in the Smithsonian Institution. Carlisle produced the early motors and when his production capability was exceeded, Brown Manufacturing produced motors for a period of time. Vernon Estes later invented a machine to mass produce model rocket engines for MMI and his production capacity far exceeded the needs of MMI.

Model Missiles also produced a scale model of the Arcon. Both models were actively advertised in major magazines like Boy's Life. Thousands of aspiring space scientists were introduced to model rocketry by these early kits. Literally starting from the ground up, G. Harry Stine developed many of the techniques for model rocketry that are taken for granted today and "wrote the book" that is still the bible for entry level and "old timers" alike. He brought the NAR to life and fought tirelessly to make model rocketry a safe and educational hobby.

Estes Industries began selling model rockets and engines by mail order and eventually bought the manufacturing tooling from MMI. G. Harry Stine spent the rest of his life promoting model rocketry.

July 17, 2005, September 21, 2015

Copyright © 2007 Semroc
www.semroc.com

About the Aerobee-Hi

The first production models of the MMI Aerobee-Hi were produced with hand-turned maple nose cones. Later production models used a soft vinyl nose cone. A parallel wound body tube was lined inside with a thin aluminum motor mount at the bottom and several wraps of manila paper in the upper section to protect from the ejection gases. The early versions used the 11/16" x 2.5" Rock-a-chute motors. The MMI Kit O01 sold for \$7.95 and included the Aerobee-Hi, launcher, and 6 standard Type A engines. These were slightly more powerful (6.7ns) than a modern B6 engine and sold separately for 6 for \$2.50.

The MMI Aerobee-Hi was not an exact scale model but was close enough for many early model rocketeers to build and fly a small version of a popular sounding rocket of the 1950's. The Retro-Repro Aerobee-Hi is designed to capture the MMI version as thousands of modelers flew in the infancy of model rocketry. The modern updates to the Aerobee-Hi are laser-cut balsa fins, precision turned balsa nose cone, and a more reliable Kevlar® shock cord mount.

BEFORE YOU START!

Make sure you have all the parts included in this kit that are listed in the Parts List in the center of these instructions. In addition to the parts included in this kit, you will also need the tools and materials listed below. Read the entire instructions before beginning to assemble your rocket. When you are thoroughly familiar with these instructions, begin construction. Read each step and study the accompanying drawings. Check off each step as it is completed. In each step, test-fit the parts together before applying any glue. It is sometimes necessary to sand lightly or build-up some parts to obtain a precision fit. If you are uncertain of the location of some parts, refer to the exploded view in the center of these instructions. It is important that you always ensure that you have adequate glue joints.

TOOLS: In addition to the parts supplied, you will need the following tools to assemble and finish this kit.



ASSEMBLY

1. These instructions are presented in a logical order to help you put your Aerobee-Hi together quickly and efficiently. Check off each step as you complete it and enjoy putting this kit together.

2. Fit the nose cone first. Insert the nose cone in the body tube and check for fit. The nose cone should be snug to hold itself in alignment. If it is too loose, add masking tape. If it is too tight, sand the shoulder slightly. Remove the nose cone and set it aside for later.

3. Prepare the shock cord as follows. Line up one end of the elastic shock cord with one end of the Kevlar® cord and tie an overhand knot at the end of the two cords. Pull the knot tight and place a small drop of white glue on the knot to prevent it from loosening.

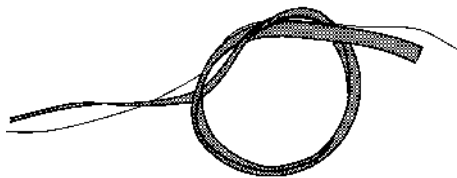

4. Tie the other end of the yellow Kevlar® cord to the thrust ring. Place a small bead of glue inside one end of the smaller engine tube. Slide the thrust ring completely into the engine tube until it is about 1/8" below the top edge of the engine tube. Insert the elastic cord and Kevlar® cord back through the engine tube.

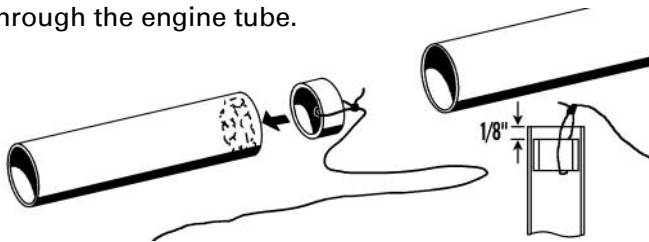

5. Put a large dab of glue on your little finger or a cotton-tipped swab and spread the glue around inside the main body tube as far as your finger (or swab) will reach, but no farther than 2 1/2". Insert the engine mount assembly into the main body tube until both ends are flush. **CAUTION:** Once you have started to push, do not stop or the assembly will "freeze" in place.

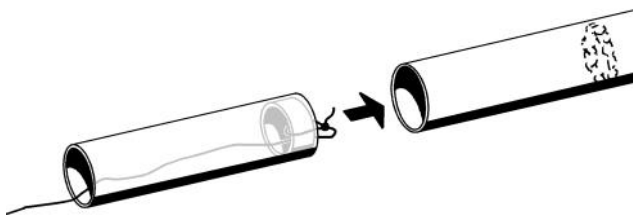

- ❑ **6.** Lightly sand each side of the laser-cut fins. Carefully push the laser-cut fins from their sheet. Start at one point on each fin and slowly and gently work around the fin.

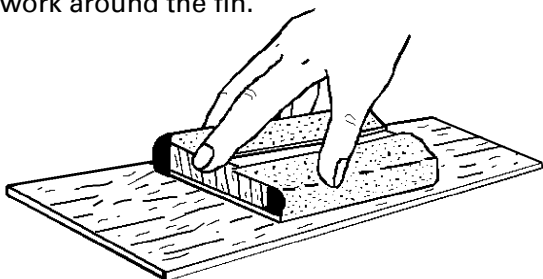

- ❑ **7.** Stack all three fins and line them up squarely. Run the fins back and forth over some fine sandpaper to get rid of the hold-in tabs as shown below. Sand three of the strakes carefully. There is an extra stroke in case one breaks.



- ❑ **8.** Round all edges except the root edge. The root edge should remain flat since it will be glued to the body tube. The trailing edge may be sanded in a streamlined taper if you want a higher performance rocket. The top edge of the strakes may be rounded.

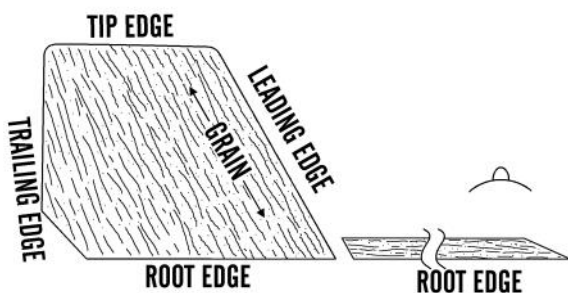

- ❑ **9.** Stand the body tube on the fin guide below and make the fin position marks on the sides of the tube. Find a convenient channel or groove such as a partially open drawer, a door jamb (as shown,) or a piece of molding. Using the channel, extend the marks the full length of the tube to provide lines for aligning the fins and strakes.



Parts List

A	1	Body Tube	BT-40W
B	1	Body Tube	ST-730
C	1	Balsa Nose Cone	BNC-40G
D	1	Laser Cut Fins	FV-2
E	1	Thrust Ring	TR-7
F	1	Launch Lug	LL-110
G	1	Screw Eye	SE-10
H	1	Elastic Cord	EC-118
I	1	Kevlar Thread	SCK-18
J	1	Plastic Parachute Pack	PC-12-24
M	1	Decal	DKV-2

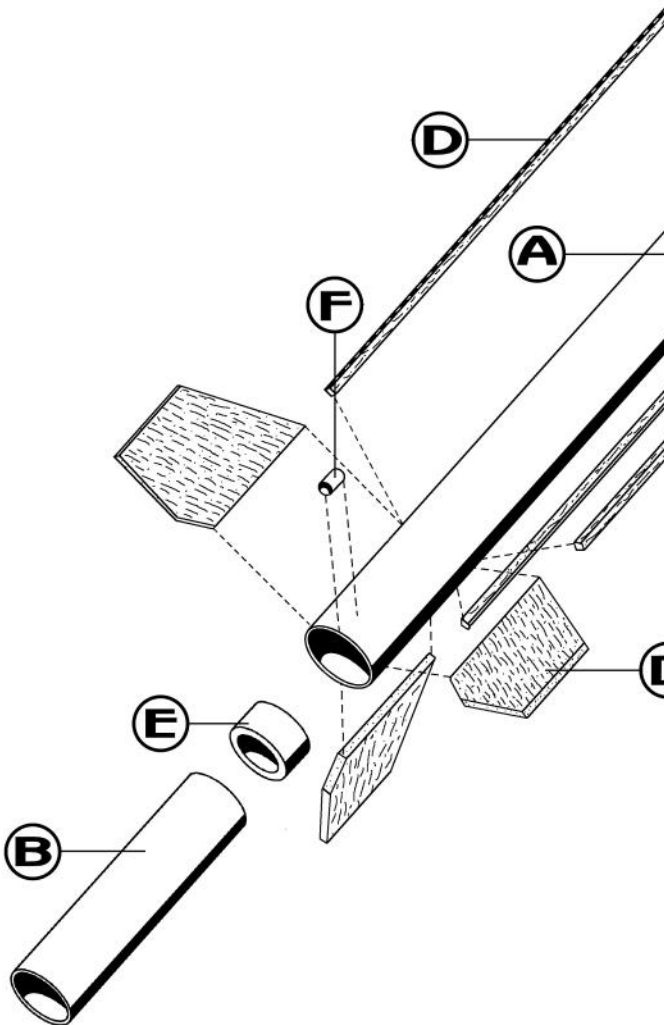

EXPLODED VIEW

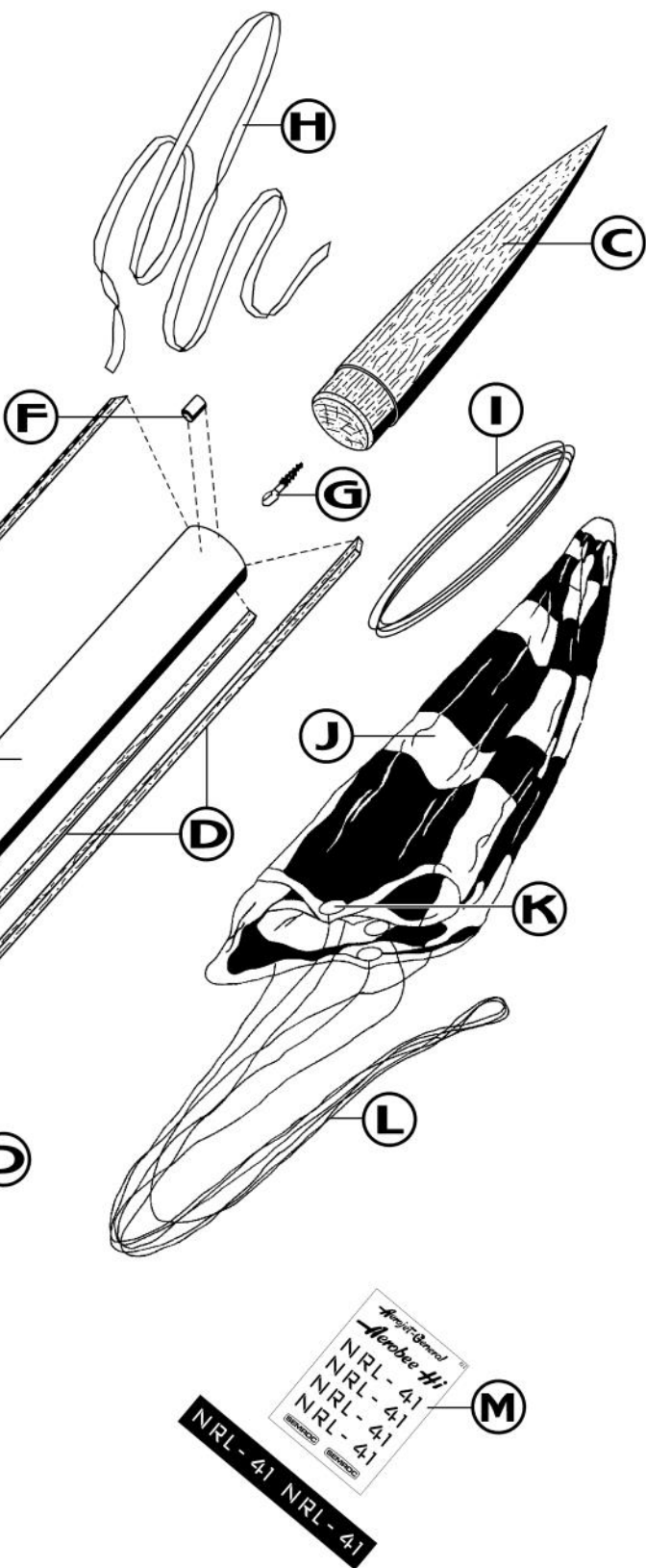

- ❑ **10.** Apply glue to the root edge of a fin and position it along one of the lines drawn on the side of the body tube. Remove, allow to dry, apply additional glue, and reposition. Repeat for the other two fins.

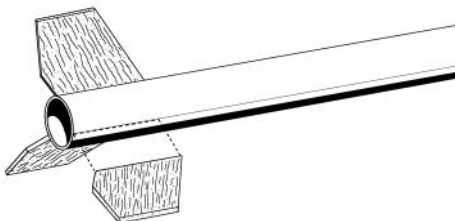

- ❑ **11.** Apply glue to the root edge of a strake and position it along one of the lines drawn on the side of the body tube. Align the end taper to match one of the fins. Remove, allow to dry, apply additional glue, and reposition. Repeat for the other two strakes.

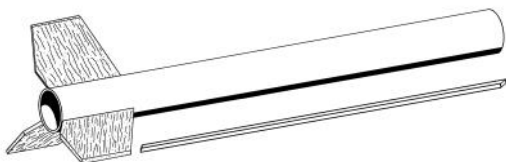

- ❑ **12.** Allow to dry standing vertically, checking for alignment visually while the assembly dries. Stuff the shock cord and Kevlar® cord into the body tube so it will remain vertical.

- ❑ **13.** Cut the launch lug into two pieces about 1/4" long. Glue one launch lug onto the body, centered between two fins and even with the bottom of the main tube. Glue the other one in line with the bottom launch lug and even with the top of the main tube. Stand the assembly vertically again and wait for all the glue to dry.



- ❑ **14.** Twist the screw eye into the center of the base of the nose cone. Unscrew it and squirt glue into the hole. Reinstall the screw eye and wipe off any excess glue. Tie the free end of the elastic shock cord to the screw eye.

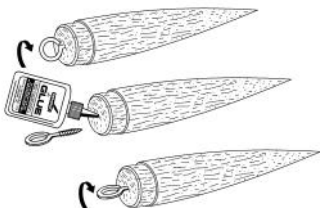

- 15.** Assemble the 12" parachute using the instructions supplied on the chute. Tie the completed parachute to the screw eye.

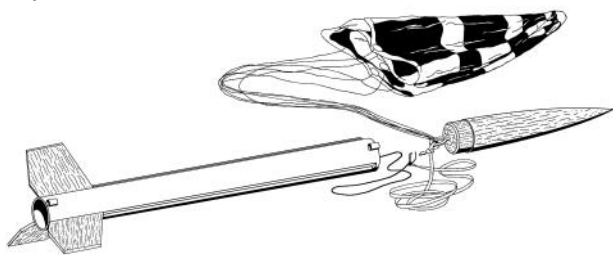

This completes the assembly of your

Aerobee Hi

FINISHING

- 16.** When the fillets have dried, prepare balsa surfaces for a smooth professional looking finish. Fill the wood grain with balsa fillercoat or sanding sealer, When dry, sand with fine sandpaper. Repeat until smooth.

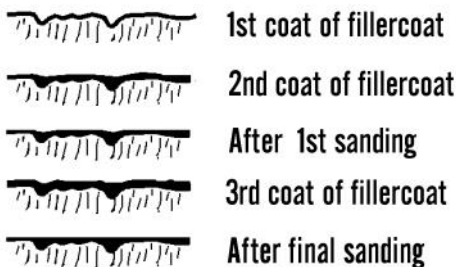

- 17.** After all balsa surfaces have been prepared, wipe off all balsa dust with a dry cloth. First spray the model with an enamel primer. Paint the nose cone silver, the main body tube and strakes orange, two fins white and the remaining fin black to match the original colors.

- 18.** Spray painting your model with a fast-drying enamel will produce the best results. PATIENCE...is the most important ingredient. Using rolled newspapers to hold the rocket, apply several thin coats, allowing each coat to completely dry before the next coat. Start each spray a few inches above the model and end a few inches below the model. Keep the can about 12" away and use quick light coats. The final coat can be a little heavier to give the model a glossy wet-looking finish.

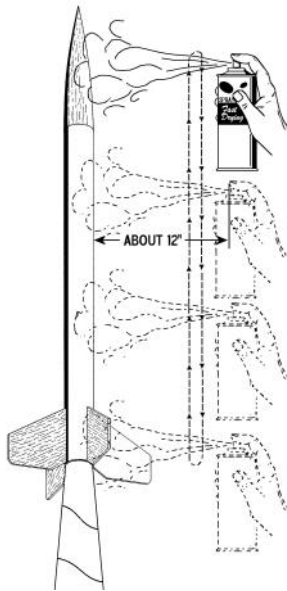

- 19.** After the paint has dried, decals should be applied. The decals supplied with the Aerobee-Hi are waterslide decals. Each decal should be cut separately from the sheet. Apply each decal before starting the next. Think about where you want to apply each decal and check for fit before wetting the decal. The two decals with white lettering on a black background are for the single black fin.

FLIGHT PREPPING

- 20.** Mounting the engine: Wrap a small amount of masking tape on the engine to make a friction fit in the main body tube.
- 21.** Pack the recovery wadding from the top of the body tube. Use a sufficient quantity to protect the parachute, but not too much that there is no room left.
- 22.** Fold the parachute and pack it and the shock cord on top of the recovery wadding. Slide the nose cone into place, making sure it does not pinch the shock cord or parachute.
- 23.** Refer to the model rocket engine manufacturer's instructions to complete the engine prepping. Different engines have different igniters and methods of hooking them up to the launch controllers.
- 24.** Carefully check all parts of your rocket before each flight as a part of your pre-flight checklist. Launch the Aerobee-Hi from a 1/8" diameter by 36" long launch rod.

LIMITATION OF LIABILITY

Model rockets are not toys, but are functional rockets made of lightweight materials and are launched with NAR or Tripoli safety certified model rocket motors, electrically ignited and flown in accordance with the NAR Model Rocket Safety Code. If misused, model rockets can cause serious injury and property damage. Semroc certifies that it has exercised reasonable diligence in the design and manufacture of its products. Semroc cannot assume any liability for the storage, transportation, or usage of its products. Semroc shall not be held responsible for any personal injury or property damage whatsoever arising out of the handling, storage, use, or misuse of our products. The buyer assumes all risks and liabilities therefrom and accepts and uses Semroc products on these conditions.

Your purchase and use of any Semroc products is construed as your agreement to and acceptance of these terms. If you do not agree to these terms and conditions, you must return the product, unused, for refund or credit.

100% SATISFACTION GUARANTEE

If you are not 100% satisfied with your Semroc product, we will make it right by providing whatever you consider fair, from refund to replacement.

Contact us at:

Semroc

www.semroc.com

JOIN THE NAR!

Sign up online at www.nar.org/semroc to join the premier model rocketry organization. Semroc fully supports the National Association of Rocketry and recognizes it as the sport's official voice. The NAR is the oldest and largest sport rocketry organization in the world. Since 1957 over 100,000 serious sport rocket modelers have joined the NAR to take advantage of the fun and excitement of organized rocketry. It is always more fun if you fly with friends. The *Sport Rocketry* magazine is one of the best ways to keep informed of new developments in the hobby.





Model Rocket Safety Code

- 1. Materials.** I will use only lightweight, non-metal parts for the nose, body, and fins of my rocket.
- 2. Motors.** I will use only certified, commercially-made model rocket motors, and will not tamper with these motors or use them for any purposes except those recommended by the manufacturer.
- 3. Ignition System.** I will launch my rockets with an electrical launch system and electrical motor igniters. My launch system will have a safety interlock in series with the launch switch, and will use a launch switch that returns to the "off" position when released.
- 4. Misfires.** If my rocket does not launch when I press the button of my electrical launch system, I will remove the launcher's safety interlock or disconnect its battery, and will wait 60 seconds after the last launch attempt before allowing anyone to approach the rocket.
- 5. Launch Safety.** I will use a countdown before launch, and will ensure that everyone is paying attention and is a safe distance of at least 15 feet away when I launch rockets with D motors or smaller, and 30 feet when I launch larger rockets. If I am uncertain about the safety or stability of an untested rocket, I will check the stability before flight and will fly it only after warning spectators and clearing them away to a safe distance.
- 6. Launcher.** I will launch my rocket from a launch rod, tower, or rail that is pointed to within 30 degrees of the vertical to ensure that the rocket flies nearly straight up, and I will use a blast deflector to prevent the motor's exhaust from hitting the ground. To prevent accidental eye injury, I will place launchers so that the end of the launch rod is above eye level or will cap the end of the rod when it is not in use.
- 7. Size.** My model rocket will not weigh more than 1,500 grams (53 ounces) at liftoff and will not contain more than 125 grams (4.4 ounces) of propellant or 320 N-sec (71.9 pound-seconds) of total impulse. If my model rocket weighs more than one pound (453 grams) at liftoff or has more than four ounces (113 grams) of propellant, I will check and comply with Federal Aviation Administration regulations before flying.
- 8. Flight Safety.** I will not launch my rocket at targets, into clouds, or near airplanes, and will not put any flammable or explosive payload in my rocket.
- 9. Launch Site.** I will launch my rocket outdoors, in an open area at least as large as shown in the accompanying table, and in safe weather conditions with wind speeds no greater than 20 miles per hour. I will ensure that there is no dry grass close to the launch pad, and that the launch site does not present risk of grass fires.
- 10. Recovery System.** I will use a recovery system such as a streamer or parachute in my rocket so that it returns safely and undamaged and can be flown again, and I will use only flame-resistant or fireproof recovery system wadding in my rocket.
- 11. Recovery Safety.** I will not attempt to recover my rocket from power lines, tall trees, or other dangerous places.

LAUNCH SITE DIMENSIONS

Installed Total Impulse	Equivalent Motor Type	Minimum Site Dimensions
0.00 — 1.25	1/4A	50
1.26 — 2.50	A	100
2.51 — 5.00	B	200
5.01 — 10.00	C	400
10.01 — 20.00	D	500
20.01 — 40.00	E	1000
40.01 — 80.00	F	1000
80.01 — 160.00	G	1000
160.01 — 320.00	2 Gs	1500