



About the Moon Glo™

The original Moon Glo was released in 1963 by Rocket Development Corporation. It used a white vellum convolute wound body tube and a hardwood nose cone. It was released as Catalog Number K-1 and retailed for \$1.50.

The Semroc Retro-Repro™ Moon Glo™ kit is designed to bring back some of the nostalgia of this early classic. The hardwood nose cone is replaced by a hard balsa nose cone. Kevlar is used for the shock cord attachment to avoid the slits in the tube.

About Rocket Development Corporation

In 1961, Irving S. Wait founded Rocket Development Corporation (RDC) in Utah. Irv was a professional rocket engineer employed at Thiokol Chemical Corporation and worked on the Minuteman and Polaris missile projects. In 1963, RDC was moved to a farm near Seymour, Indiana to have more space for development of rocket engines.

RDC developed the first successful high-power composite solid propellant model rocket engines. These engines included the Enerjet series which were sold to individuals. Larger Enerjet engines were sold for industrial and educational use. RDC was acquired by Centuri Engineering in 1969 and became the Enerjet division. For several years, Centuri sold the E and F impulse Enerjet composite motors.

Although Coaster Corporation had developed large black power engines years earlier, the composite engines from RDC would form the basis for modern mid-power and high-power rocketry. RDC's use of fiberglass, graphite, and modern propellants have stood the test of time. Even though RDC is no longer with us as a model rocket manufacturer, their influence continues to be felt by old and new rocketeers fifty years later.

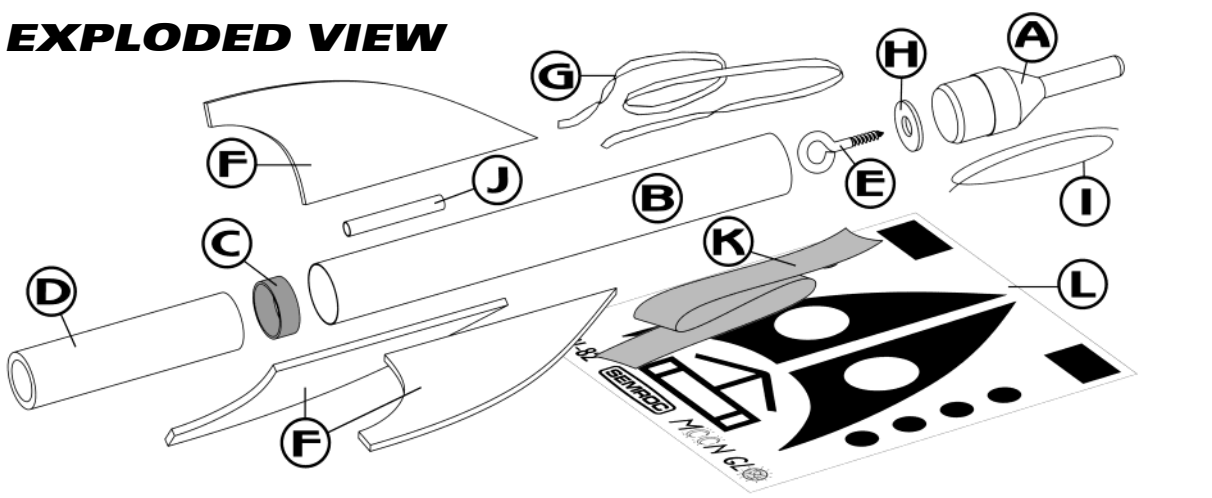

- Parts List**
- A 1 Balsa Nose Cone BNC-20MG
 - B 1 Body Tube BT-20HW
 - C 1 Engine Block EB-20A
 - D 1 Empty Casing..... MC-727
 - E 1 Screw Eye SE-12
 - F 1 Laser-cut Fins FV-82
 - G 1 Elastic Cord EC-118
 - H 1 Washer Weight..... WW-7A
 - I 1 Kevlar® Thread SCK-12
 - J 1 Launch Lug..... LL-2A
 - K 1 Streamer RS-118
 - L 1 Decal..... DKV-82

TOOLS

In addition to the parts supplied, you will need the following tools to assemble and finish this kit.



July 13, 2011, March 17, 2016

Copyright © 2011 Semroc
www.semroc.com

ASSEMBLY

- ❑ 1. These instructions are presented in a logical order to help you put your Moon Glo™ together quickly and efficiently. Check off each step as you complete it and we hope you enjoy putting this kit together.
- ❑ 2. Tie one end of the yellow Kevlar cord (SCK-12) to the engine block (EB-20A). Mark the empty engine casing (MC-727) 1/4" from one end. Pull the free end of the Kevlar cord back through the engine casing as shown.

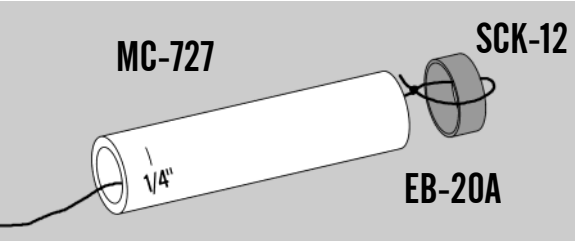

- ❑ 3. Put a large dab of glue on your little finger or a cotton-tipped swab and spread the glue around inside the main body tube (BT-20HW) as far as your finger (or swab) will reach, but no farther than 2 1/2". Insert the engine block just inside the end of the body tube. Use the engine casing to push the engine block until the mark on the casing is even with the end of the body tube. **CAUTION: Once you have started to push, do not stop or the ring will "freeze" in place.** Remove the empty case immediately. Push the Kevlar cord back through the tube and out the top.

BT-20HW

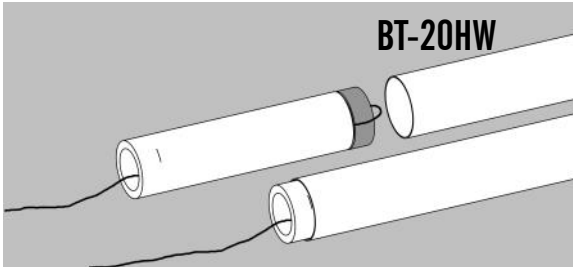

❑ 4. Lightly sand each side of the laser-cut fin sheet (FV-82). Carefully push the laser-cut fins from their sheet. Start at one point on each fin and slowly and gently work around the fin. Round all the curved edges.

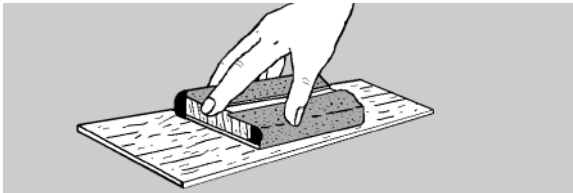

❑ 5. Stand the body tube on the fin guide below and make the fin position marks on the sides of the tube. Find a convenient channel or groove such as a partially open drawer, a door jamb (as shown,) or a piece of molding. Using the channel, extend the marks the full length of the tube to provide lines for aligning the fins.

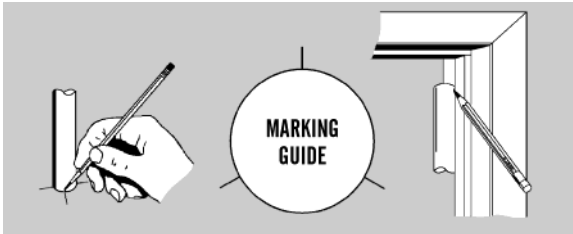

❑ 6. Apply glue to the root edge of a fin and position it along one of the lines drawn on the side of the body tube. Make sure you glue it on the end closest to the engine block. Remove, allow to almost dry, apply additional glue, and reposition. Repeat for the other two fins.

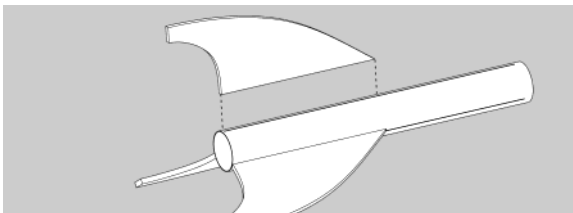

❑ 7. Glue the launch lug (LL-2A) onto the body tube, centered between two fins and about 1/2" from the bottom.

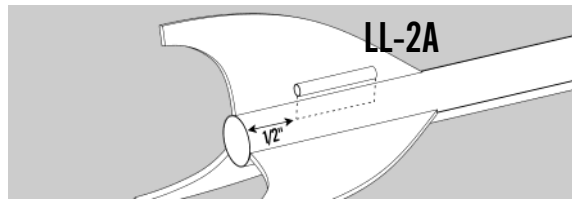

❑ 8. After the fin assembly is completely dry, run a small bead of glue along both sides of each fin-body tube joint. Using your forefinger, smooth the glue into fillets.

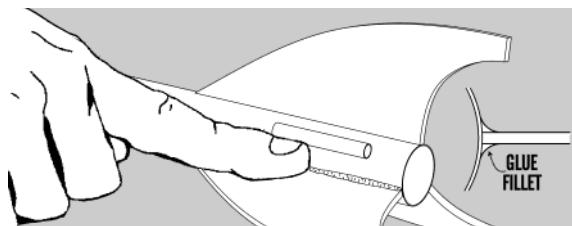

❑ 9. Turn the screw eye (SE-12) into the center of the base of the nose cone (BNC-20MG). Unscrew it and squirt glue into the hole. Reinstall the screw eye through the washer weight (WW-7A) and into the nose cone. Wipe off any excess glue.

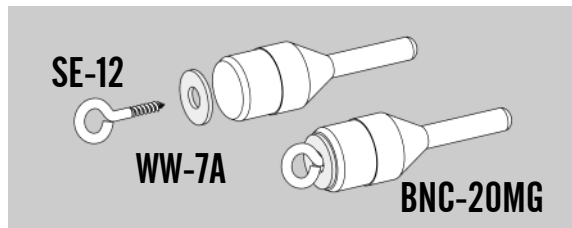

❑ 10. Tie one end of the elastic cord (EC-118) to the free end of the Kevlar cord and the other end to the screw eye. Tie the streamer (RS-118) to the center of the elastic cord.

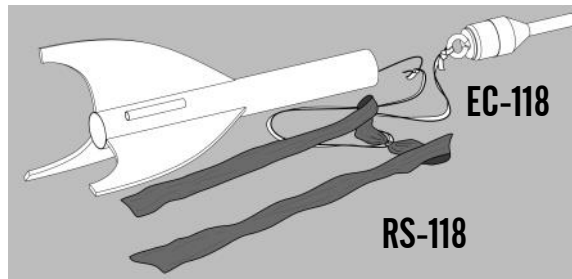

FINISHING

❑ 11. When the fillets have dried, prepare balsa surfaces for a smooth professional looking finish. Fill the wood grain with balsa fillercoat or sanding sealer. When dry, sand with fine sandpaper. Repeat until smooth.

 1st coat of fillercoat

 2nd coat of fillercoat

 After 1st sanding

 3rd coat of fillercoat

 After final sanding

❑ 12. After all balsa surfaces have been prepared, wipe off all balsa dust with a dry cloth. First spray the model with an enamel primer. Choose a high visibility color like white or yellow for the final color. Spray painting your model with a fast-drying enamel will produce the best results. PATIENCE...is the most important ingredient. Use several thin coats, allowing each coat to completely dry before the next coat. Start each spray a few inches above the model and end a few inches below the model. Keep the can about 12" away and use quick light coats. The final coat can be a little heavier to give the model a glossy wet-looking finish.

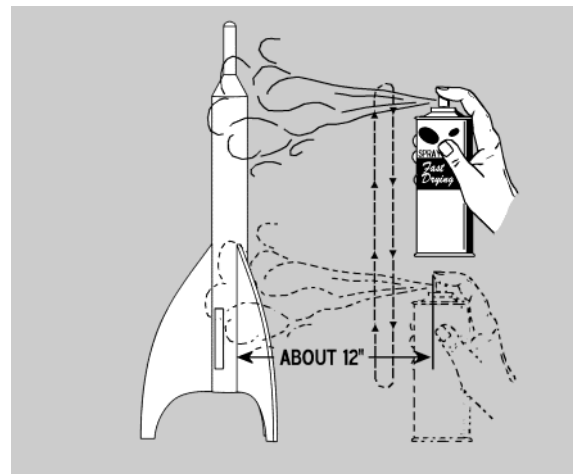

❑ 13. After the paint has dried, decals should be applied. The decals supplied with the Moon Glo™ are waterslide decals. Each decal should be cut separately from the sheet. Think about where you want to apply each decal and check for fit before wetting the decal. Use the cover photo for suggested placement. Dip each decal in a small dish of water that has a drop of detergent. It will take about 30 seconds before the decal is loose enough to apply. Slide the decal in place and use the paper backing to work the bubble out. Repeat for all the decals.

FLIGHT PREPPING

❑ 14. Mounting the engine: The engine must have masking tape applied to keep it from kicking out of the body tube at ejection time. Don't use too much tape or the engine will be too difficult to remove from the rocket.

❑ 15. Pack the recovery wadding from the top of the body tube. Use a sufficient quantity to protect the streamer, but not too much that there is no room left.

❑ 16. Roll the streamer and pack it and the shock cord on top of the recovery wadding. Slide the nose cone into place, making sure it does not pinch the shock cord or streamer.

❑ 17. Refer to the model rocket engine manufacturer's instructions to complete the engine prepping. Different engines have different igniters and methods of hooking them up to the launch controllers.

❑ 18. Carefully check all parts of your rocket before each flight as a part of your pre-flight checklist. Launch the Moon Glo™ from a 1/8" diameter by 36" long launch rod.