

SEMROC

SPEV™

SPACE EXPLORATION VEHICLE

NASA Inspired Design

**1972 Retro
Reproduction**

Payload Sections

**Precision Turned
Balsa Parts**

**Laser Cut
Balsa Fins**

**Water Slide
Decals**

**Parachute
Recovery**

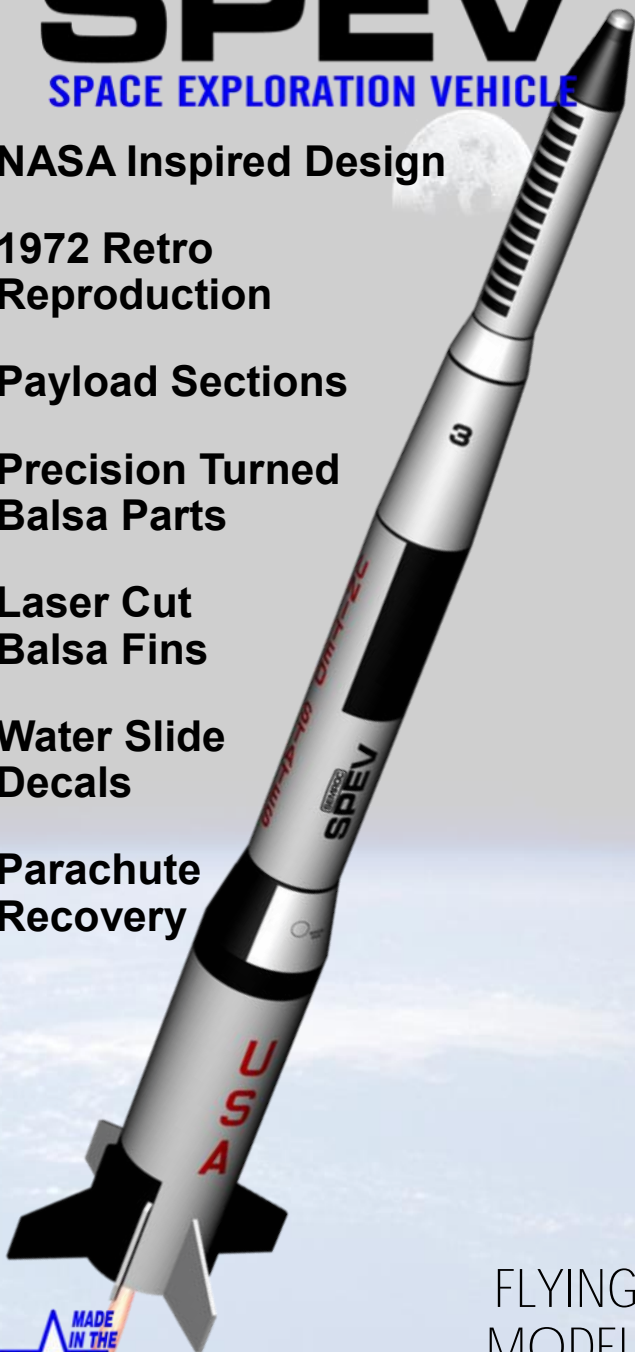

**FLYING
MODEL
ROCKET KIT**

Made in the U.S.A by Semroc - Dayton, Ohio

SPEV™

Kit No. KV-61

| | Specifications | Engine | Approx. Altitude |
|---------------|-----------------------|---------------|-------------------------|
| Body Diameter | 2.217" (5.6 cm) | B4-4 | 250' |
| Length | 24.7" (62.7 cm) | B6-4 | 250' |
| Fin Span | 5.4" (13.7 cm) | C6-5 | 600' |
| Net Weight | 2.2 oz. (62.4 g) | | |

Skill Level 2

What is a Retro-Repro™ ?

A Retro-Repro is a retro reproduction of an out-of-production model rocket kit. It is a close approximation of a full scale model of an early historically significant model rocket kit from one of the many companies that pioneered the hobby over the past half century. A Retro-Repro is not a true clone or identical copy of the original. It incorporates improvements using modern technology, while keeping the flavor and build appeal of the early kits.

About Estes Industries, Inc.

In July 1958, G. Harry Stine of Model Missiles, Inc. in Denver, Colorado approached Vern Estes about making model rocket engines for them. On January 15, 1959, Vern's automated model rocket engine fabricating machine, "Mabel", produced the first of many millions of Estes model rocket engines. In 1960, Estes was producing more engines than Model Missiles could sell. Vern and his wife Gleda opened a mail order rocket company and introduced the Astron Scout and Astron Mark.

In 1961, a catalog was mimeographed and hand stitched on Gleda's sewing machine. Later that year, Estes Industries had outgrown the confined space in Denver. In December 1961, the entire operation was moved to an old farm in Penrose, Colorado quickly establishing the small town as the "Model Rocket Capital of the World."

Estes Industries was sold to Damon in September 1969. The name Estes is synonymous with model rocketry. Almost everyone remembers growing up firing Estes rockets or knowing someone that did. Estes Industries has introduced millions of youngsters of all ages to model rocketry for almost half a century.

February 28, 2007, December 30, 2016

Copyright © 2007 Semroc
www.semroc.com

About the SPEV™

The Estes SPEV was released in 1972 in Model Rocket News Volume 12 Number 3 as what would be a very limited run. It did not appear in a catalog and was discontinued in MRN volume 12 Number 4 in November, 1972 discounted to \$1.59 from the original \$1.99 price. It was designed by Bill Simon, purportedly, as a "Spare Parts Elimination Vehicle." It did share parts with the Little Joe II, Mars Lander, and Thor-Agena B, so the possibility exists. The Little Joe II and Thor-Agena B were both discontinued in 1972 lending more credibility to the rumor.

The Retro-Repro SPEV™ is a faithful reproduction of the original using all balsa couplers and nose cone. It uses laser-cut balsa fins for ease of construction. The original 18" parachute is replaced with a 12" two-color chute for limiting drift. A sturdier engine mount is provided along with a Kevlar® shock cord mount. No "spare parts" were eliminated in the production of the Semroc SPEV!

BEFORE YOU START!

Make sure you have all the parts included in this kit that are listed in the Parts List in the center of these instructions. In addition to the parts included in this kit, you will also need the tools and materials listed below. Read the entire instructions before beginning to assemble your rocket. When you are thoroughly familiar with these instructions, begin construction. Read each step and study the accompanying drawings. Check off each step as it is completed. In each step, test-fit the parts together before applying any glue. It is sometimes necessary to sand lightly or build-up some parts to obtain a precision fit. If you are uncertain of the location of some parts, refer to the exploded view in the center of these instructions. It is important that you always ensure that you have adequate glue joints.

TOOLS: In addition to the parts supplied, you will need the following tools to assemble and finish this kit. Masking tape is also required.



ASSEMBLY

- 1.** These instructions are presented in a logical order to help you put your SPEV™ together quickly and efficiently. Check off each step as you complete it and enjoy putting this kit together.

ENGINE MOUNT

- 2.** Tie a loop in one end of the yellow Kevlar® cord using an overhand knot.



- 3.** Bend the engine hook slightly so it forms a slight bow in the direction shown.



- 4.** Insert one end of the engine hook through the loop in the yellow Kevlar® cord and into the pre-punched engine tube slot.

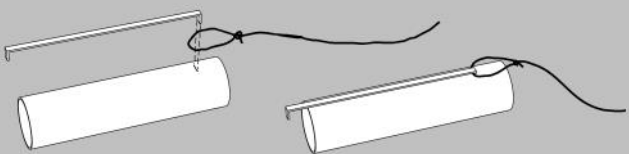

- 5.** Wrap a piece of masking tape around the center of the engine mount. Apply a bead of glue on the engine hook between the tape and the Kevlar loop. Glue the thrust ring in place on top of the engine hook as shown.

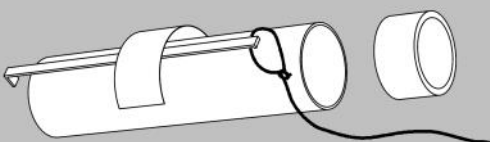

- ❑ **6.** Slide the top centering ring (without a notch) onto the engine tube just even with the end of the engine hook as shown. Apply a bead of glue around both sides of the ring. Pull the Kevlar cord back into the engine mount tube to keep it out of the way in future steps.

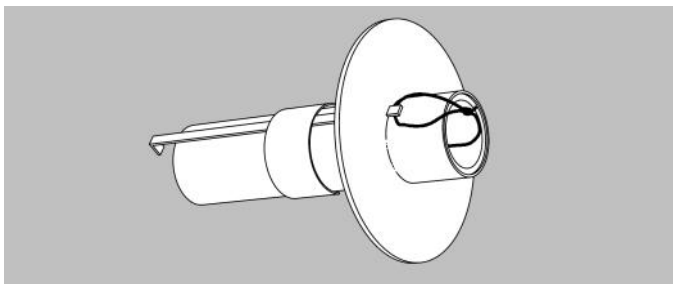

- ❑ **7.** Slide the bottom centering ring onto the engine tube with the notch centered over the engine hook and $\frac{3}{4}$ " from the end of the tube. Apply a bead of glue around both sides of the ring keeping glue away from the engine hook. Continue turning the assembly until the glue does not run. Set the assembly aside to dry completely.

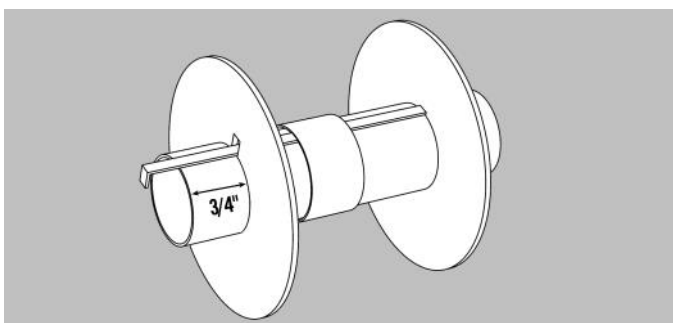

PAYLOAD SECTION

- ❑ **8.** Locate the largest adapter (TA-6070) and the middle sized body tube (BT-60FG). Place a bead of glue around the inside of one end of the body tube and insert the smaller end of the tube adapter.

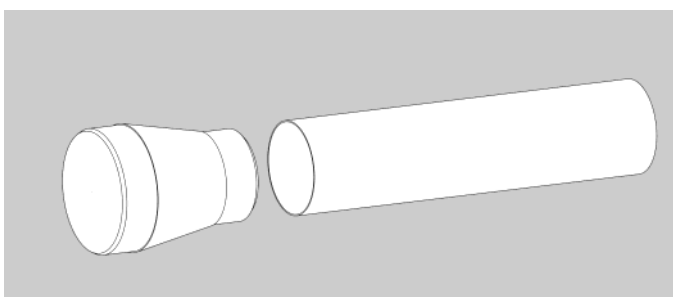

- 9.** If you will use the middle section as a payload section, do not glue the pieces together in this step. Locate the long balsa adapter (TA-5260C) and either glue it into the body tube or use masking tape to get a good friction fit.

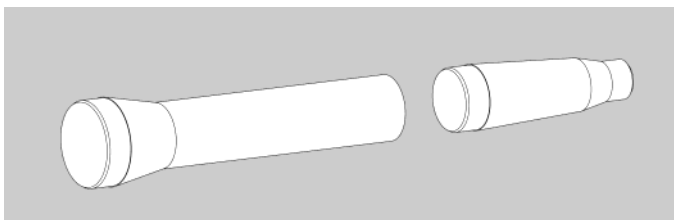

- 10.** Place a small bead of glue inside one end of the remaining body tube (BT-52S). Insert the small end of the long balsa adapter (TA-5260C) into the body tube.

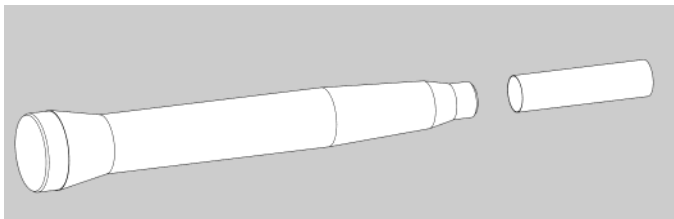

- 11.** If you plan on using the top section for payloads, friction fit the nose cone with masking tape. Otherwise, glue the nose cone in place.

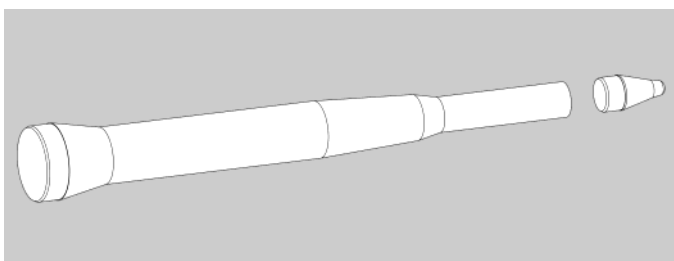

PREPARE THE FINS

- 12.** Lightly sand each side of the laser-cut fins. Carefully push the laser-cut fins from their sheet. Start at one point on each fin and slowly and gently work around the fin.

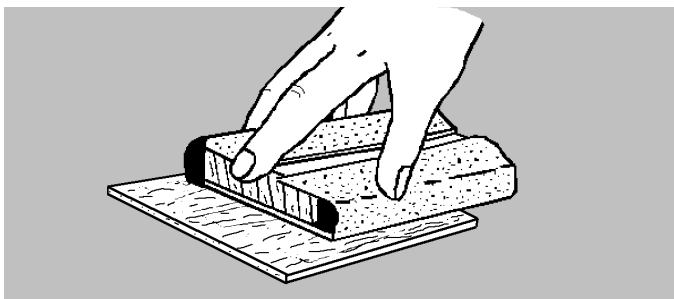

- ❑ **13.** Stack all the main fins together. Line them up squarely and sand the fins back and forth over some fine sandpaper to get rid of the hold-in tabs as shown below. Repeat with the four small fins.

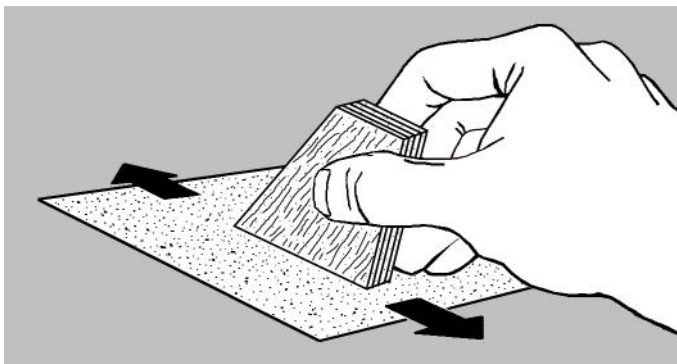

- ❑ **14.** Round all edges except the root edges (which will be glued to the body tube).

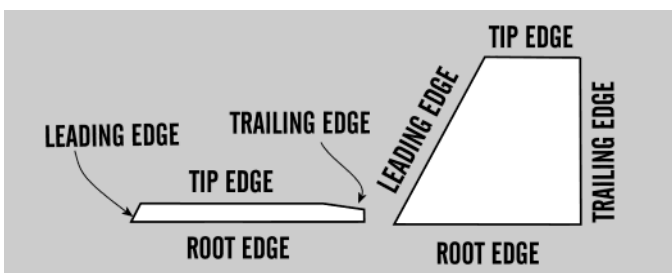

MARK THE TUBE

- ❑ **15.** Stand the body tube on the fin guide below. Mark the eight fin positions and one launch lug (LL) position on the side of the tube. Find a convenient channel or groove such as a partially open drawer, a door jamb (as shown,) or a piece of molding. Using the channel, extend the marks the length of the tube to provide lines for aligning the fins and launch lug.

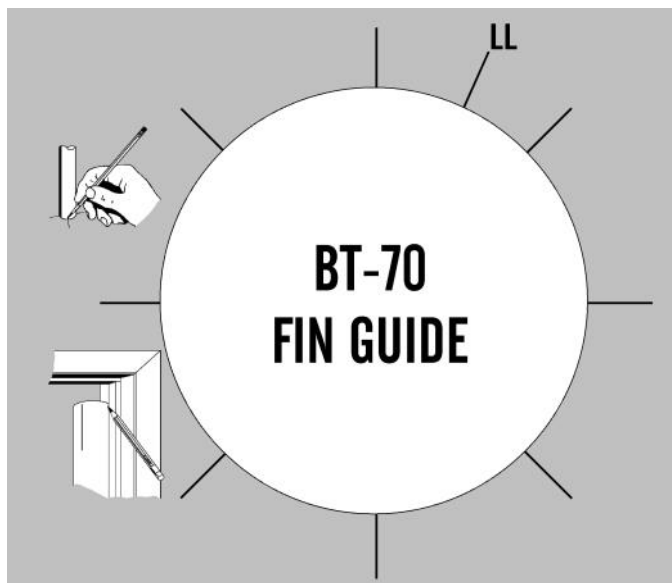

Parts List

| | | | |
|---|---|--------------------------|----------|
| A | 1 | Nose Cone | BNC-52G |
| B | 1 | Body Tube | BT-52S |
| C | 1 | Transition | TA-5260C |
| D | 1 | Body Tube | BT-60FG |
| E | 1 | Transition | TA-6070 |
| F | 1 | Body Tube | BT-70H |
| G | 1 | Laser Cut Fins | FV-61 |
| H | 1 | Body Tube | ST-730E |
| I | 1 | Centering Ring Set | CR-KV-61 |
| J | 1 | Thrust Ring | TR-7 |
| K | 1 | Engine Hook | EH-28 |
| L | 1 | Launch Lug | LL-2B |
| M | 1 | Screw Eye | SE-2 |
| N | 1 | Kevlar Thread | SCK-12 |
| O | 1 | Elastic Cord | EC-136 |
| P | 1 | Plastic Parachute..... | CP-12-24 |
| Q | 1 | Tape Discs | TD-6 |
| R | 1 | Shroud Line | SLT-6 |
| S | 1 | Decal | DKV-61 |

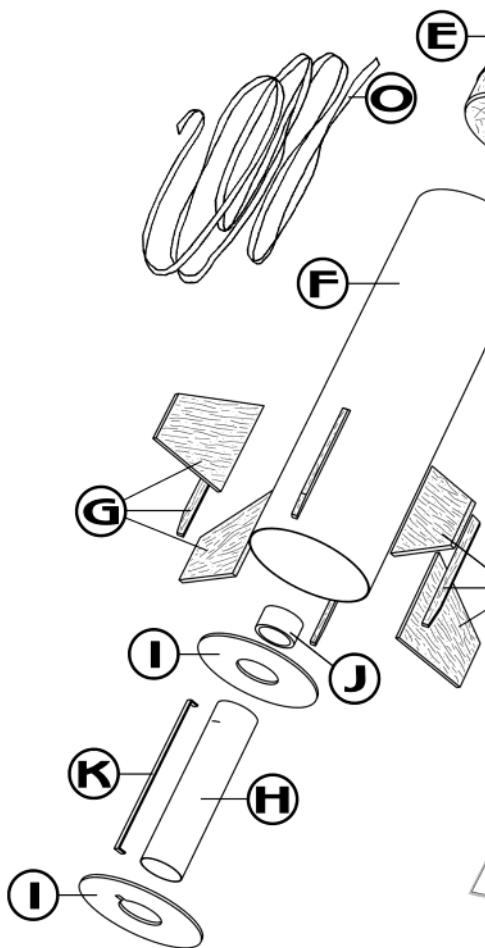

EXPLODED VIEW

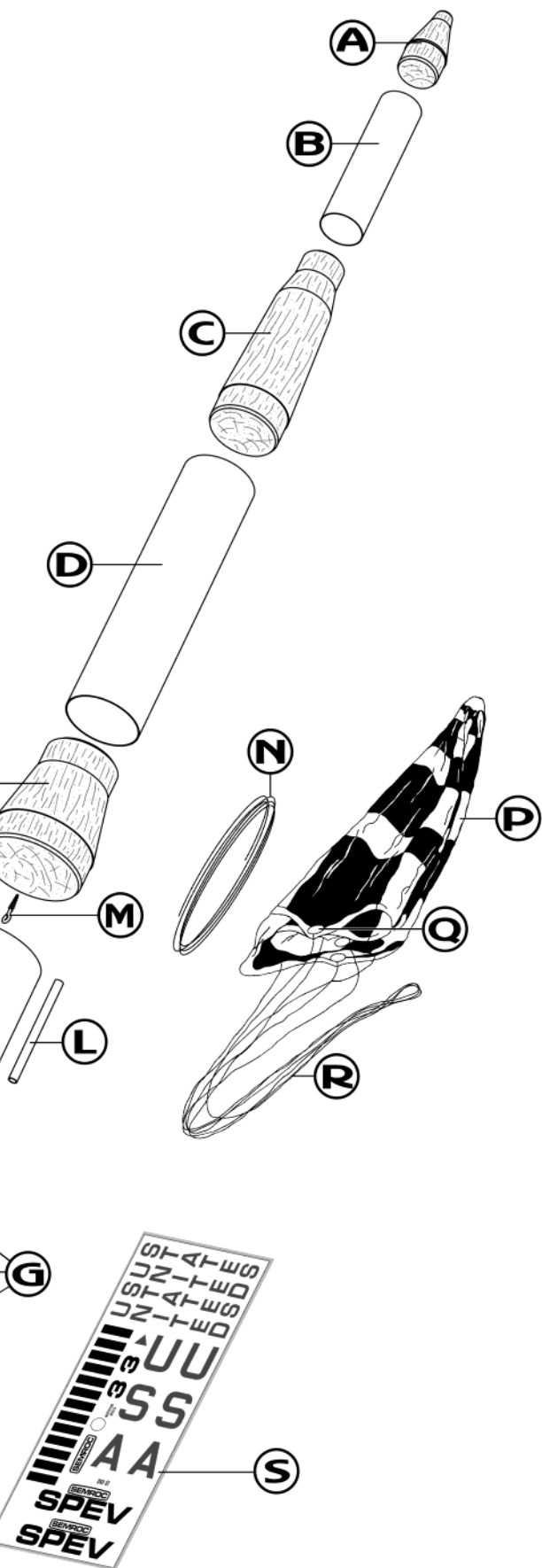

ENGINE MOUNT

- ❑ **16.** Apply a bead of glue inside one end of the large body tube (BT-70H). Insert the engine mount sliding it into position with the end of the engine tube even with the end of the body tube. Leave in an upright position while the glue sets. Then turn the assembly upside down and apply a bead of glue around the bottom joint.

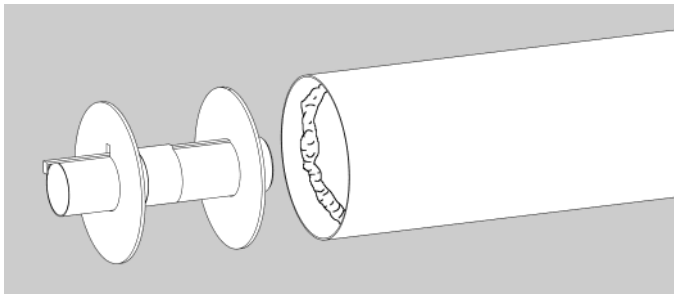

- ❑ **17.** Apply glue to the root edge of a large fin and position it along one of the lines drawn on the side of the main body tube. Remove, allow to dry, apply additional glue, and reposition. Repeat for the other three fins alternating lines to leave a space for the small fins.

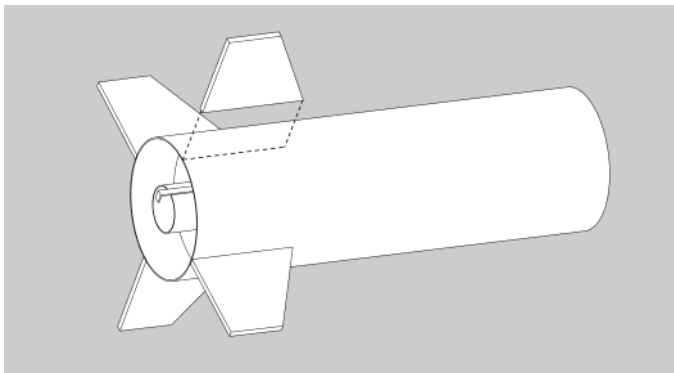

- ❑ **18.** Apply all four small fins between the four main fins with a 5/16" overhang as shown. These may be installed flush with the end to make them less vulnerable to breakage. Refer to the diagram to ensure the tapered end is toward the bottom of the tube. Stand on top end and allow to dry completely.

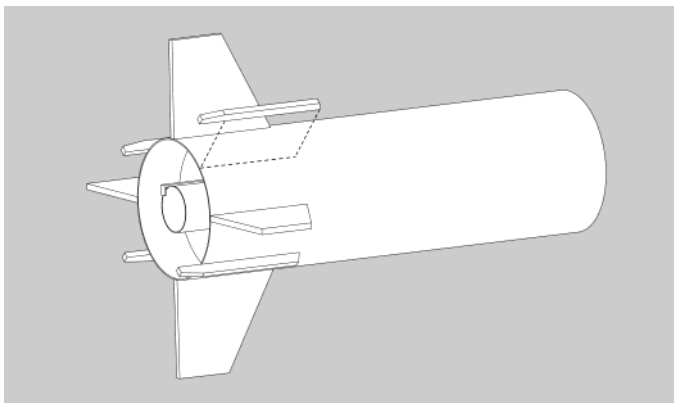

- 19.** Apply a fillet of glue along each fin and body tube joint. Use your finger to smooth the glue to the shape as shown. This adds much strength to the joint.

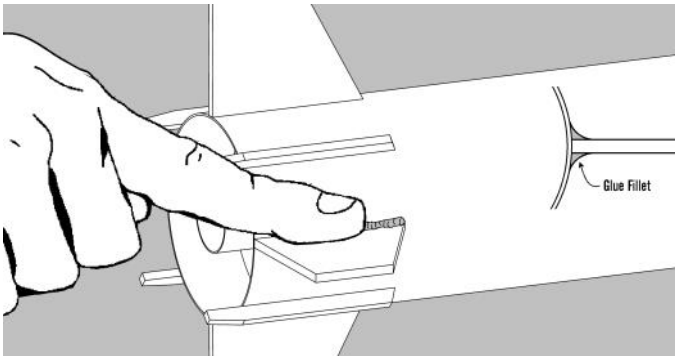

- 20.** Glue the launch lug into position between two fins on the LL line and even with the top of the main body tube.

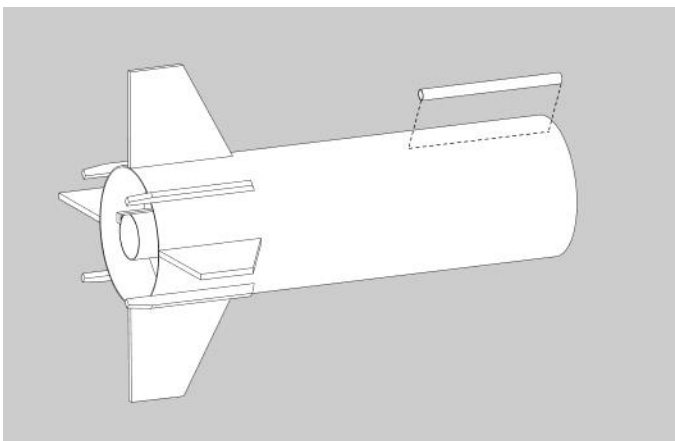

FINAL ASSEMBLY

- 21.** Twist the screw eye into the center of the base of the large tube adapter and squirt glue into the hole. Reinstall the screw eye and wipe off any excess glue.

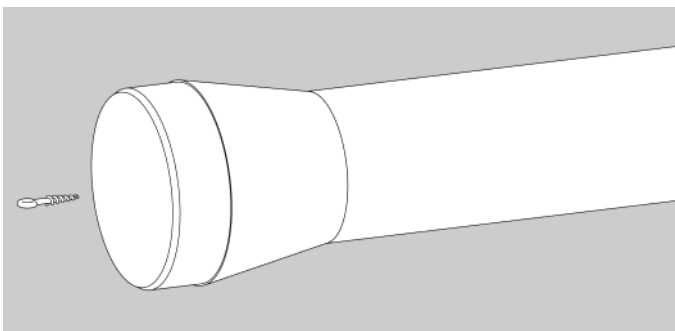

- 22.** Assemble the parachute using the instructions printed on the canopy.

- 23.** Prepare the shock cord as follows. Shake the Kevlar shock cord free and pull it out from the top of the main body tube. Line up one end of the elastic shock cord with the free end of the Kevlar cord extending from the top of the body tube. Tie an overhand knot at the end of the two cords. Pull the knot tight and place a small drop of white glue on the knot to prevent it from loosening. Tie the loose end of the elastic to the screw eye on the payload section. Attach the parachute to the shock cord about 12" from the screw eye.

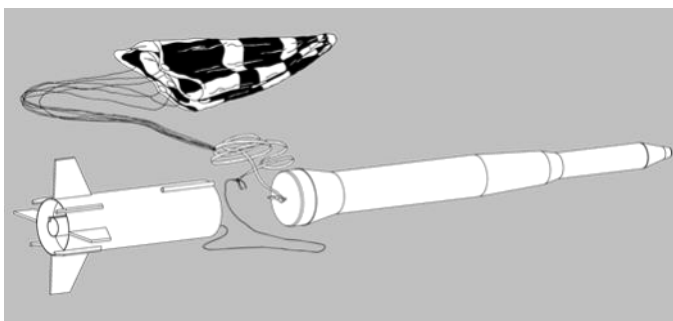

This completes the assembly of your

SEMROC
SPEV™
 SPACE EXPLORATION VEHICLE

FINISHING

- 24.** When the fillets have dried, prepare balsa surfaces for a smooth professional looking finish. Fill the wood grain with balsa fillercoat or sanding sealer, When dry, sand with fine sandpaper. Repeat until smooth.



1st coat of fillercoat



2nd coat of fillercoat



After 1st sanding



3rd coat of fillercoat



After 1st sanding

❑ **25.** After all balsa surfaces have been prepared, wipe off all balsa dust with a dry cloth. First spray the model with an enamel primer, then spray a base color of gloss white.

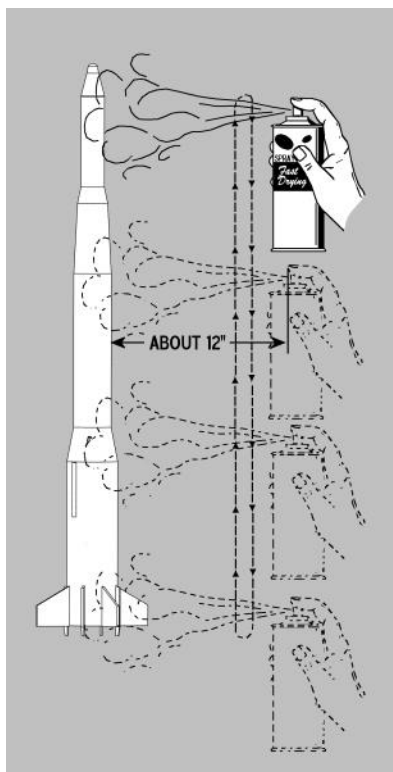

❑ **26.** Spray painting your model with a fast-drying enamel will produce the best results. PATIENCE...is the most important ingredient. Use several thin coats, allowing each coat to completely dry before the next coat. Start each spray a few inches above the model and end a few inches below the model. Keep the can about 12" away and use quick light coats. The final coat can be a little heavier to give the model a glossy wet-looking finish.

❑ **27.** The SPEV™ can now be painted with its final colors. The nose cone should be painted black with a silver tip. Refer to the front photo for color placement. The fin section should be masked to provide a roll pattern. The transitions can also be masked and painted with black roll patterns.

❑ **28.** After the paint has dried, decals should be applied. The decals supplied with the SPEV™ are waterslide decals. Keep the top roll pattern as one piece and align it on the top tube. The two "United States" decals are placed on the middle tube. The large "USA" decals are placed on the lower tube. Apply each decal before starting the next. Check for fit before wetting the decal. A drop of detergent in the water will allow for more movement before the decal sets. Refer to the photo on the front for placement of the decals.

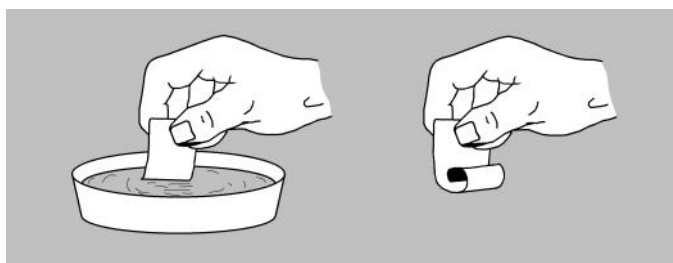

FLIGHT PREPPING

- 29.** Mounting the engine: Insert the engine and make sure the engine hook keeps the engine in snugly. The hook may be slightly bent to make sure the engine is retained.

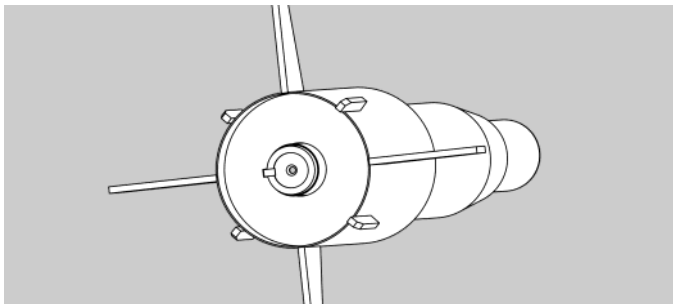

- 30.** Pack the recovery wadding from the top of the body tube. Use a sufficient quantity to protect the parachute, but not too much that there is no room left.

- 31.** Fold the parachute and pack it and the shock cord on top of the recovery wadding. Slide the payload section into place, making sure it does not pinch the shock cord or parachute.

- 32.** Refer to the model rocket engine manufacturer's instructions to complete the engine prepping. Different engines have different igniters and methods of hooking them up to the launch controllers.

- 33.** Carefully check all parts of your rocket before each flight as a part of your pre-flight checklist. Launch the SPEV™ from a 1/8" diameter by 36" long launch rod.

LIMITATION OF LIABILITY

Model rockets are not toys, but are functional rockets made of lightweight materials and are launched with NAR or Tripoli safety certified model rocket motors, electrically ignited and flown in accordance with the NAR Model Rocket Safety Code. If misused, model rockets can cause serious injury and property damage. Semroc certifies that it has exercised reasonable diligence in the design and manufacture of its products. Semroc cannot assume any liability for the storage, transportation, or usage of its products. Semroc shall not be held responsible for any personal injury or property damage whatsoever arising out of the handling, storage, use, or misuse of our products. The buyer assumes all risks and liabilities therefrom and accepts and uses Semroc products on these conditions.

Your purchase and use of any Semroc products is construed as your agreement to and acceptance of these terms. If you do not agree to these terms and conditions, you must return the product, unused, for refund or credit.

100% SATISFACTION GUARANTEE

If you are not 100% satisfied with your Semroc product, we will make it right by providing whatever you consider fair, from refund to replacement.

Contact us at:

Semroc

www.semroc.com

JOIN THE NAR!

Sign up online at www.nar.org to join the premier model rocketry organization. Semroc fully supports the National Association of Rocketry and recognizes it as the sport's official voice. The NAR is the oldest and largest sport rocketry organization in the world. Since 1957 over 100,000 serious sport rocket modelers have joined the NAR to take advantage of the fun and excitement of organized rocketry. It is always more fun if you fly with friends. The *Sport Rocketry* magazine is one of the best ways to keep informed of new developments in the hobby.





Model Rocket Safety Code

- 1. Materials.** I will use only lightweight, non-metal parts for the nose, body, and fins of my rocket.
- 2. Motors.** I will use only certified, commercially-made model rocket motors, and will not tamper with these motors or use them for any purposes except those recommended by the manufacturer.
- 3. Ignition System.** I will launch my rockets with an electrical launch system and electrical motor igniters. My launch system will have a safety interlock in series with the launch switch, and will use a launch switch that returns to the "off" position when released.
- 4. Misfires.** If my rocket does not launch when I press the button of my electrical launch system, I will remove the launcher's safety interlock or disconnect its battery, and will wait 60 seconds after the last launch attempt before allowing anyone to approach the rocket.
- 5. Launch Safety.** I will use a countdown before launch, and will ensure that everyone is paying attention and is a safe distance of at least 15 feet away when I launch rockets with D motors or smaller, and 30 feet when I launch larger rockets. If I am uncertain about the safety or stability of an untested rocket, I will check the stability before flight and will fly it only after warning spectators and clearing them away to a safe distance.
- 6. Launcher.** I will launch my rocket from a launch rod, tower, or rail that is pointed to within 30 degrees of the vertical to ensure that the rocket flies nearly straight up, and I will use a blast deflector to prevent the motor's exhaust from hitting the ground. To prevent accidental eye injury, I will place launchers so that the end of the launch rod is above eye level or will cap the end of the rod when it is not in use.
- 7. Size.** My model rocket will not weigh more than 1,500 grams (53 ounces) at liftoff and will not contain more than 125 grams (4.4 ounces) of propellant or 320 N-sec (71.9 pound-seconds) of total impulse. If my model rocket weighs more than one pound (453 grams) at liftoff or has more than four ounces (113 grams) of propellant, I will check and comply with Federal Aviation Administration regulations before flying.
- 8. Flight Safety.** I will not launch my rocket at targets, into clouds, or near airplanes, and will not put any flammable or explosive payload in my rocket.
- 9. Launch Site.** I will launch my rocket outdoors, in an open area at least as large as shown in the accompanying table, and in safe weather conditions with wind speeds no greater than 20 miles per hour. I will ensure that there is no dry grass close to the launch pad, and that the launch site does not present risk of grass fires.
- 10. Recovery System.** I will use a recovery system such as a streamer or parachute in my rocket so that it returns safely and undamaged and can be flown again, and I will use only flame-resistant or fireproof recovery system wadding in my rocket.
- 11. Recovery Safety.** I will not attempt to recover my rocket from power lines, tall trees, or other dangerous places.

LAUNCH SITE DIMENSIONS

| Installed Total Impulse (N-sec) | Equivalent Motor Type | Minimum Site Dimensions (ft.) |
|---------------------------------|-----------------------|-------------------------------|
| 0.00 — 1.25 | 1/4A | 50 |
| 1.26 — 2.50 | A | 100 |
| 2.51 — 5.00 | B | 200 |
| 5.01 — 10.00 | C | 400 |
| 10.01 — 20.00 | D | 500 |
| 20.01 — 40.00 | E | 1000 |
| 40.01 — 80.00 | F | 1000 |
| 80.01 — 160.00 | G | 1000 |
| 160.01 — 320.00 | 2 Gs | 1500 |