

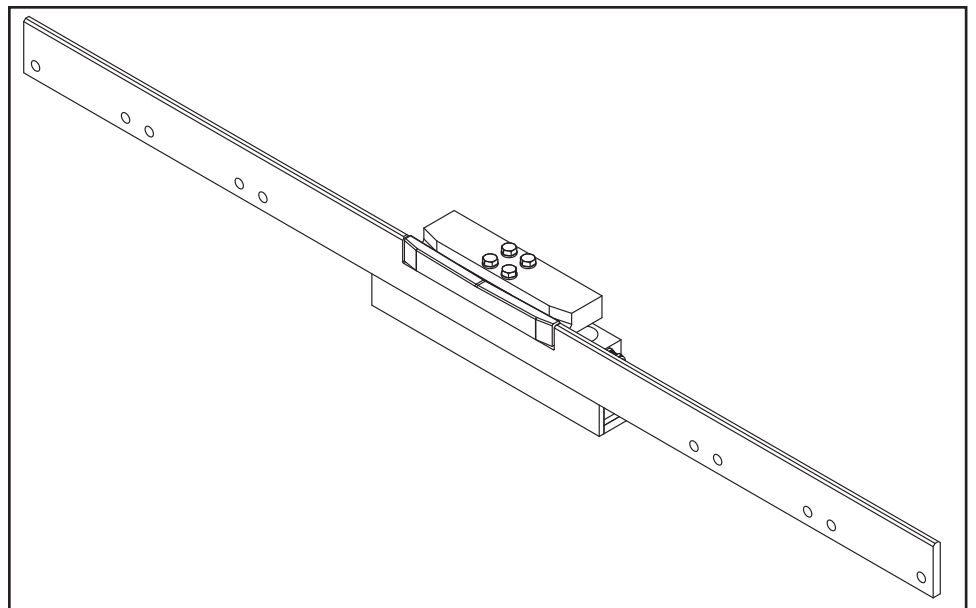

PRODUCT CATALOG

New!
5270 Series
Monorail Scale

Special Products





5270 Series Monorail Scale

FOB: St. Johnsbury, VT 05819

Price Includes: Dead rail, live rail, load cell with 10' of cable

Specifications

Capacity 1000 lbs total; 450 kgs
 Division size 0.5 lbs / 0.5 kgs
 Rail construction 304 Series stainless steel
 Excitation voltage 5 - 15 VDC
 Resolution 2000d (Commercial); 5000d Non-commercial
 Overload 150% FS
 Temperature compensation 14 to 104°F; -10 to +40°C

Load Cell Specifications

Capacities 500 kg
 Cable length 10 feet
 Construction 17-4 pH Stainless steel
 Protection IP68/69K
 Bridge Resistance 350Ω

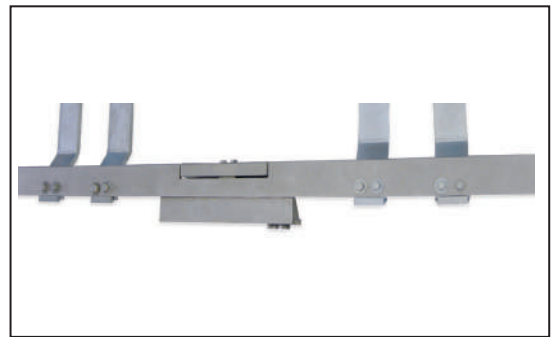

CC# 18-114
MC# AM-6111



| Product | Description | Shipping Weight | Wholesale |
|---------|--|-----------------|------------|
| 35262 | 5270 Series Monorail Scale 5270 Series Monorail Scale, 48" long dead rail (3/8"), 8" live rail | 100 lbs. | \$2,711.00 |

Notes:

- For other rail sizes, please enter a Solutions Request.
- The 5270 Series Monorail Scale will work with any analog instrument, however, **to meet USDA requirements** (0.1 lb tare) you **must** pair the scale with an FB2255 series instrument **with firmware revision 2.05 or higher**.
 Refer to the instrumentation section of the catalog for complete product information.

