

DRAYSON'S LARGE BALL

MAJOR GENERAL A W DRAYSON, F.R.A.S. (1897)

THE ART OF PRACTICAL BILLIARDS FOR AMATEURS

CHAPTER XIV ALL ROUND CANONS Approved by W J Peall

Many amateurs are very fond of playing for "all round cannons;" that is, to make their own ball after striking the ball they aim at travel all round the table, and, perhaps, after hitting three or four cushions, make a canon. The harder they hit their own ball, and the more they drive the balls about the table, the better they seem pleased with their performance. As a rule all round canons do not pay, they are more often missed than they are made. If missed, they may leave a long score for a skilful adversary; if made, it is a mere chance whether the balls are left so as to render a second score almost a certainty. Sometimes, however, all round canons must be played for when the game is in a desperate condition; and they may be played for with advantage when the third ball is what is termed "a large ball."

"A large ball" is when this ball is in a corner of the table, and is only three or four inches from the side and bottom, or side and top, pockets.

If the striker's ball can be made to travel round the table after striking the second ball, a canon may be made by this ball striking the third ball direct or off either cushion. This canon may be attempted when a player, giving an injudicious miss in baulk, leaves his own ball near, we will say, the right-hand pocket, and only a few inches from the right-hand side and bottom cushions. Many amateurs will then place their own ball on the right side of the baulk, and play at the red which is on the spot; striking the red on the left side, they cause their own ball to come off from the top and side cushion and travel into the right-hand corner; but before their own ball has reached the adversary's ball, the red has run down table and "kissed" the adversary's ball out of the way. If, therefore, this canon is played for, and the adversary's ball is in the right-hand bottom corner, the player should place his own ball on the left of the baulk, and should play on to the red with a slight amount of left-hand side; his own ball will come round the table equally as well, whilst the red ball, instead of kissing away the adversary's ball, will strike slightly below the right middle pocket, and will therefore leave the adversary's ball where it was, and a canon will be the result.

A frequenter of a billiard room will hear day after day indifferent players complaining of their bad luck in having canons "kissed away" from them ; the real fact being that these complainers place their ball, or strike it, in such a way that it is ten to one that the canon is kissed away, whereas a little more knowledge would prevent such a result.....

MAC'S COMMENTS Alfred Wilks shood hav sed that the very best pozzy iz three or four inches from one cushion & a foot or more from the other, especially if u would be happy to see the qball fall in the pocket. Alf beleevd in spirits, & woz a friend of Arthur Conan Doyle.

26 BALLS LUCKY 1 shows an arc of 26 balls showing the total width & angle available for the qball when played from the Dee & off yellow (not shown, sitting up the table) & off the top-cush & top-left-cush for a cannon on red (not shown) near the right-baulk-pkt. Here the 26ball width is limited & defined by the midpkts.

LUCKY ZONES A red sitting in the hatched triangular **LUCKY-B-ZONE** or in the hatched triangular **LUCKY-S-ZONE** enjoys the greatest chance of a lucky cannon. The exact size shape & pozzity of these two zones would depend on the attack-angle & pace & sidespin of the qball, & the slipperyness of the cushions. There will be a pair of mirror-image lucky-zones (not shown) near the other baulk-corner for shots played clockwise.

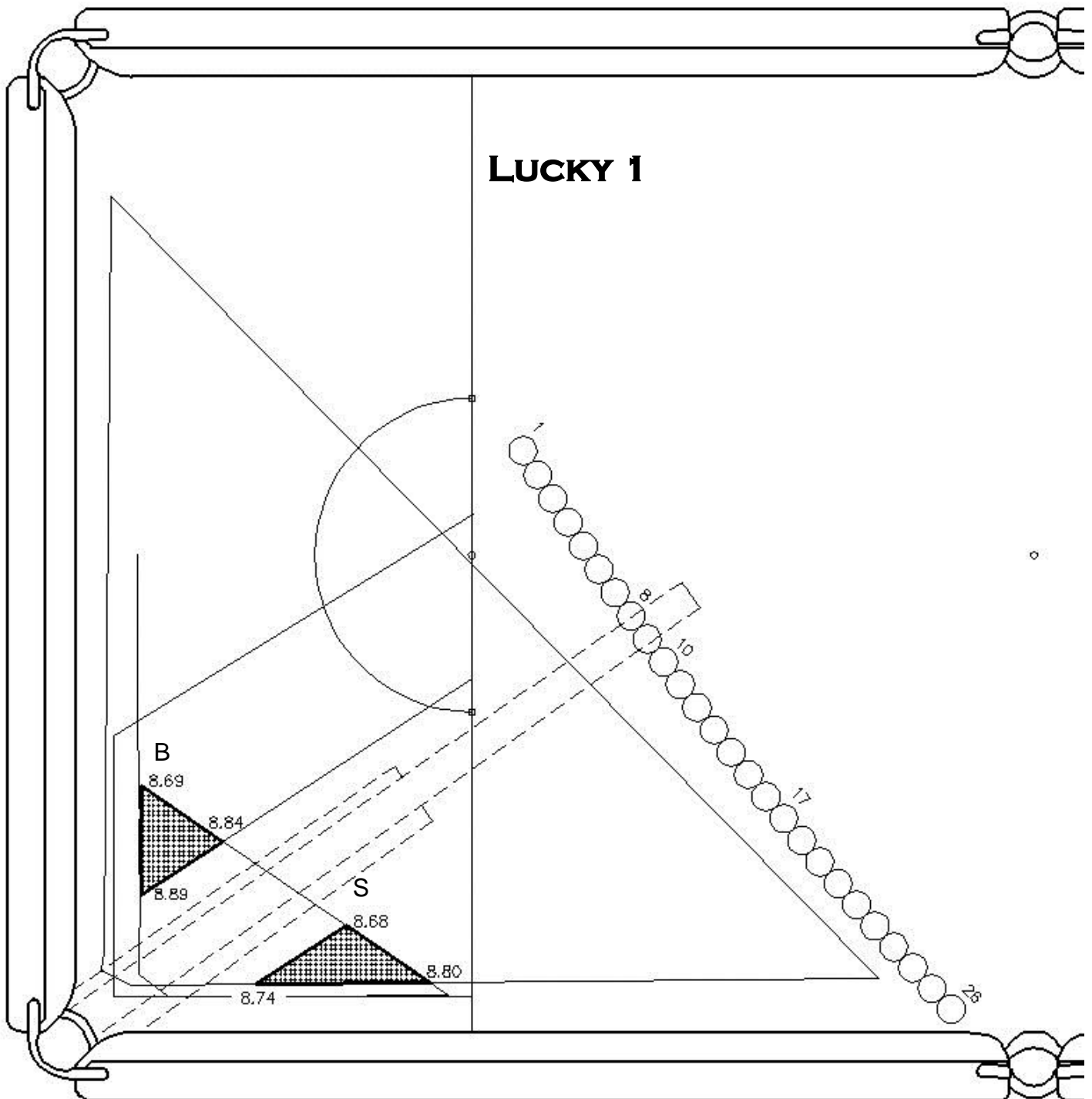

LUCKY-B-ZONE 5 CANNONINGS

DIREKT CANNON (2.00, 2.00, 2.00) LUCKY 1 & LUCKY 2.

Any red well away from a cushion anywhere on the table allways prezents a width of say 2 balls for a simple direkt cannon. This iz a very large margin-for-error. Thusly the chance of a direkt cannon on a red anywhere in baulk iz say at worst 2 in 26 (slightly less than 2 in 26 if the red iz frozen to a cushion). Here "direkt" means that the qball duznt firstly hit the baulk-cush or a baulk-side-cush. If u kan more often than not send the qball within 8balls (left or right) of the red then your chances are 2 in 16. A more akurat player might expekt to get a direkt cannon 2 times in 8 trys. This applys to both lucky-zones.

BAULK CUSHION (2.05, 2.07, 2.07) The chance of getting a cannon after rebounding off the baulk-cush iz exakty 2.00 meazured at the red, but it iz a little over 2.00 if meazured before rebound. This gain iz due to some rebound-angles being less perpendikular than attack-angles, this varying for the 3 corners of the triangle koz the loss of rebound-angle iz sometimes greater if the attack-angle iz lesser.

SIDE CUSHION (2.33, 2.27, 2.28) Here the qball gets a cannon after rebounding off the side-cush.

SIDE & BAULK (2.38, 2.23, 2.38) Here the qball gets the cannon after rebounding off the side-cush then baulk-cush.

JAW CANNONS (0.13, 0.12, 0.11) It iz possible to get a cannon after the qball hits the baulk-jaw & or the side-jaw. The baulk-jaw prezents a width of 0.50 balls (az shown in Lucky 2). The side-jaw prezents a width of 0.75 balls (az shown). Therefor u kan expekt 1.25 attempts in 26 or in 16 or in 8 to hit a jaw or jaws. Some jawing shots will rezult in a jaw-cannon, the odds are greater if the red iz close to the pocket & if at least 1ball kleer off a cush. At the lucky-baulk-cush-zone praps 1 in 10 jawings rezult in a jaw-cannon. Thusly i am adding gussed figures of 0.13, 0.12 & 0.11. Re the 0.75 ball side-jaw width, this iz wider than the 0.50ball baulk-jaw partly koz a qball hitting the flat just before the side-jaw will then rebound & catch the baulk-jaw.

TOTAL RED WIDTHS (8.89, 8.69, 8.84) These are the effektiv total cannon widths for a red sitting at the vertices. Inside the zone its in between.

INOFFS (1.33). If the red duznt block or partly block its path the qball enjoys a 1.33ball wide pathway leading to an inoff az shown. This 1.33 ball wide path sits tween the 0.50 ball & 0.75 ball jaw-cannon pathways. The baulk-cush-zone duznt block or partly block the inoff pathway, & the pocket-width (1.33) kan be added to the red-widths (8.89, 8.69, 8.84), bringing the grand total effektiv width for a cannon or inoff to 10.22, 10.02 & 10.17 balls.

GRADUAL TRANZITIONS The lucky-zones are not much luckyer than areas just outside the zones. There iz a gradual loss of luck az the red gets closer to the cushions or away from the zones. A small change in pozzy duznt rezult in a sudden loss of a way of cannoning, komplete loss of any one way of cannoning happens outside a lucky-zone, but it happens gradually over a transition-area at least 1 ball wide, sometimes 2 balls wide.

LUCKY 2

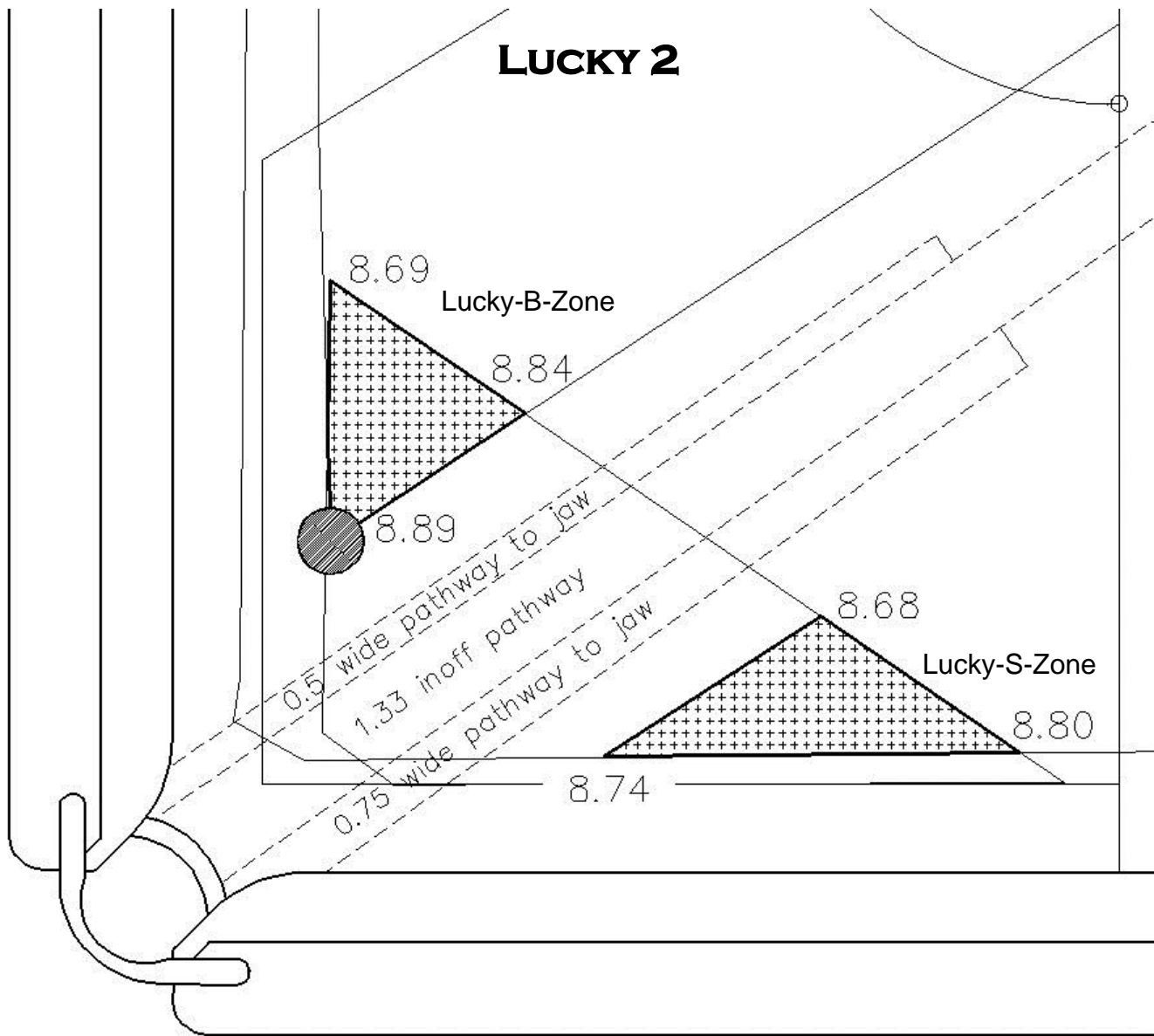

LUCKY-S-ZONE 5 CANNONINGS

Direkt Cannon	(2.00, 2.00, 2.00)
Baulk Cushion	(2.05, 2.07, 2.07)
Side Cushion	(2.32, 2.28, 2.26)
Baulk&Side	(2.24, 2.36, 2.24)
Jaw Cannons	(0.13, 0.12, 0.11)
Total Red Widths	(8.74, 8.80, 8.68)
Add InOffs (1.33)	(10.07, 10.13, 10.01)

LUCKY-B-ZONE WHERE TO AIM

17.8 BALLS Looking at the arc of qballs approaching baulk, approx 16 of the 26 will pass direktly or indirektly throo or close to the lucky-B-zone. Allowing for the geometry of the radiating trajekts of the qballs, this arc of 16 balls would be over 18 balls wide if drawn at the pocket, & 17.8 balls wide near the zone itself.

MAC'S 57.4% Thusly the odds of a cannon are say 8.89, 8.69 & 8.84 in 17.8, which iz 49.9%, 48.8% & 49.7%. The odds of an inoff adds 1.33 in 17.8 which iz 7.5%, bringing the totals to 57.4%, 56.3% & 57.2%.

MAC'S AIM Mac kan only fully enjoy this 57.4% if he kan reliably send the qball well inside the 17.8ball arc, to enjoy all 5 ways of cannoning. In fakt Mac shood aim for the center of the 17.8ball arc, ie the baulk-pkt (or more exaktly allmost a ½ ball right-of-center of the pocket (ie nearer the side-jaw)).

8.89 VERTEX If the red iz sitting on the 8.89 vertex of the lucky-B-zone, then where shood Mac aim?? The obvious candidates for aim are (1) the red, (2) the pocket, (3) halfway tween red & pocket. If Mac karnt reliably shoot a pattern much tighter than 17.8 balls then Mac shood aim for the pocket az mentioned abov (or, more exaktly, a ¼ ball off center towards the side-jaw). This aim-point leevs 8.9 balls on eech side (totalling 17.8balls), & any trajekt wider than 8.9 balls left of this aim-point will catch the left-mid-pkt. Here the numerikal equality of the 8.89 & the 8.9 iz an unhappy coincidence & iz sure to konfuze, sorry.

DAVID'S 8 BALL PATTERN David kan reliably shoot an 8 ball wide pattern in the corner. The red iz sitting on the 8.89 vertex. Where shood David aim?

1. DAVID AIMS @ RED Here he loozes the chance of a side-cush-cannon (2.33 bekums 0.00), & side-baulk cannons (2.38 bekums 0.00), & allmost a halfball of the side-jaw jaw-cannons (0.13 bekums 0.08). Hencely hiz odds for a cannon are 4.13 in 8 (51.6%). Adding 1.33 (16.6%) for the inoff makes 5.46 in 8 (68.3%).

2. DAVID AIMS @ THE POCKET Here he loozes the chance of a side-cush-cannon (2.33 bekums 0.00), & loozes 1.55 of the baulk-cush cannon (2.05 bekums 0.50), & hiz odds for a cannon will be 5.01 in 8, which iz 62.6%. Adding 1.33 (16.6%) for the inoff makes it 6.34 in 8 (79.2%).

3. DAVID AIMS ½ BALL BEFORE THE POCKET This aim-point iz nearnuff where the straight face of the side-cush-face meets the kurv of the side-jaw. It iz 4.0 balls wide of the center of the red (the first aim-point), & 1.2 balls wide of the center of the pocket (the second aim-point). Uzing this here (third) aim-point David loozes the chance of a baulk-cush-cannon (2.05 bekums 0.00), & he loozes a half of the direkt-cannon (2.00 bekums 1.00). David's odds for a cannon will be 5.84 in 8, which iz 73.0%. Adding 1.33 (16.6%) for the inoff makes it 7.17 in 8 (89.6%).

68.3% 79.2% 89.6% David's best aim-point seems to be 4.0 balls wide of the red, probly giving a side-cush-first cannon. This might bump the red away from the pocket. Dave's gotta ask hizself a question: "Do I feel lucky?" Well, do ya, punk?