

29 INSIDE-CANNONS

29 CANNONS INSIDE 1 & TABLE 1 I attempted 29 inside-cannons. The yellow woz halfway tween the pyramid-spot & right-cush. I played from the yellow-spot, kontakting the yellow thick-halfball on its rhs, using left-spin. The qball hit the right-cush then top-cush then left-cush. The red woz sitting near the lucky-S-zone az shown. Dia1 shows an inoff.

The line of yellows shows pozzys where u need a similar thick halfball kontakt with some left-spin, playing from the yellow-spot. One problem with inside-cannons (ie 3-cushion cannons) iz knowing & judging the angles. This here ideal-line heading for the center of the dee iz a good guide. A yellow lying nearer the side-cush would need a thinner kontakt or more left-side. A yellow lying nearer the centerline might need zero side.

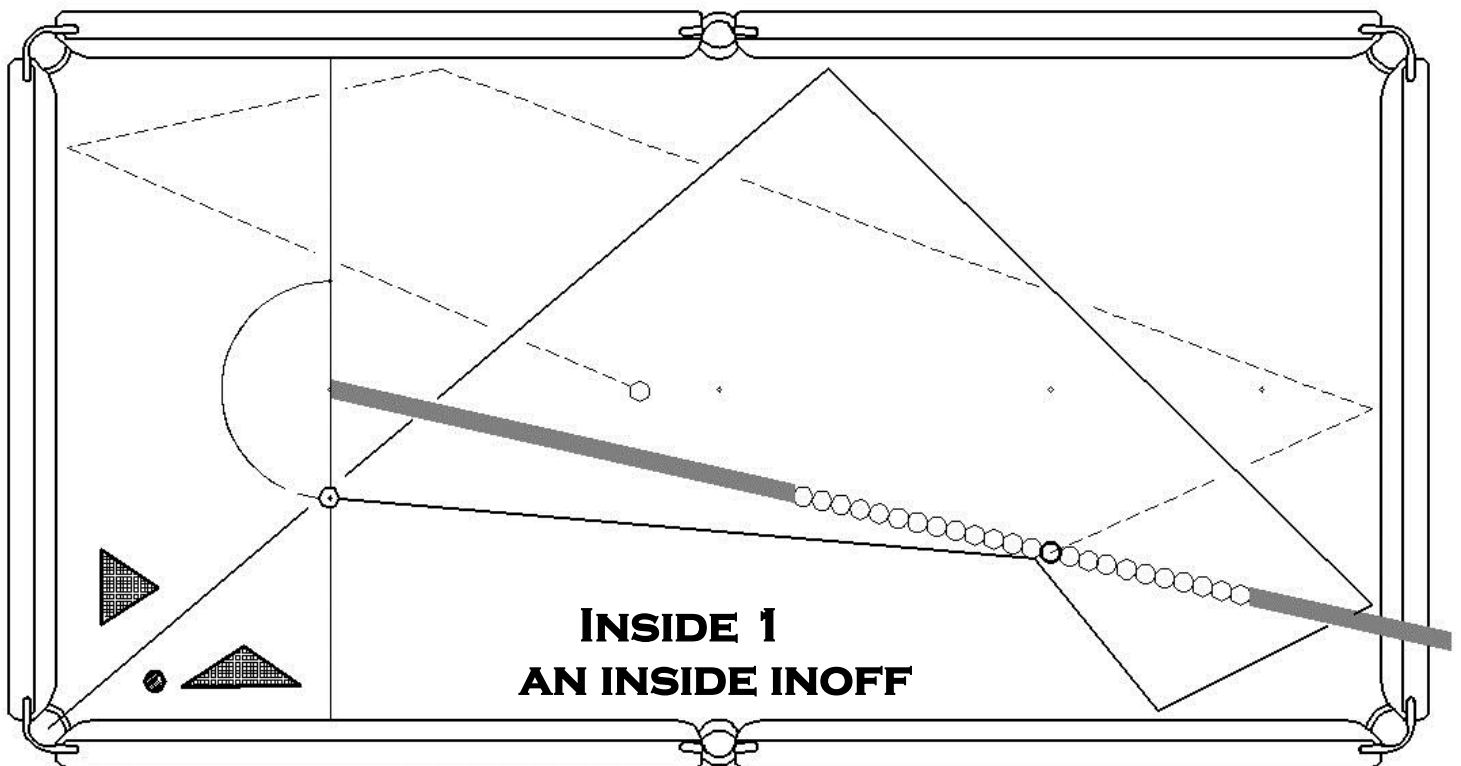

20 CANNONS I got 20 cannons in 29 shots (69.0%)(0 off bottom-cush)(3 off bottom&side cush)(0 off bottom-jaw)(1 off side-jaw)(10 direkt)(6 off the side-cush).

3 INOFFS I got 3 inoffs in 29 shots (10.3%). If u are keen on getting the inoff then u must make sure the yellow ends up out of baulk, otherwize the inoff iz wasted (koz u are double-baulked). I hit the yellow thick & hard to take it in & out of baulk. On Shot 3 & 4 & 5 the yellow caught a jaw of the left-mid-pkt, but stayed out of baulk ok. On Shot 21 & 27 i left the yellow in-baulk koz i hit too thin (but here i woz experimenting). And on Shot 26 i potted yellow in the left-baulk-pkt (koz again i woz experimenting). Re the 3 inoffs, i had 1 fair leev, & 2 poor.

6 MISSES Shot 9 missed the direkt-cannon by 1mm & hit the side-jaw. Shot 13 missed like Shot 9. Shot 16 missed, koz it hit the bottom-jaw. Shot 20 missed, koz it hit the side-cush @ 600mm. Here i woz experimenting by hitting the yellow halfball with zero side, & i knew it would miss (i just wanted to see how much). Shot 29 missed by a hair twice. Shot 24 (not shown) missed koz the qball & yellow kollided near the left-mid-pkt.

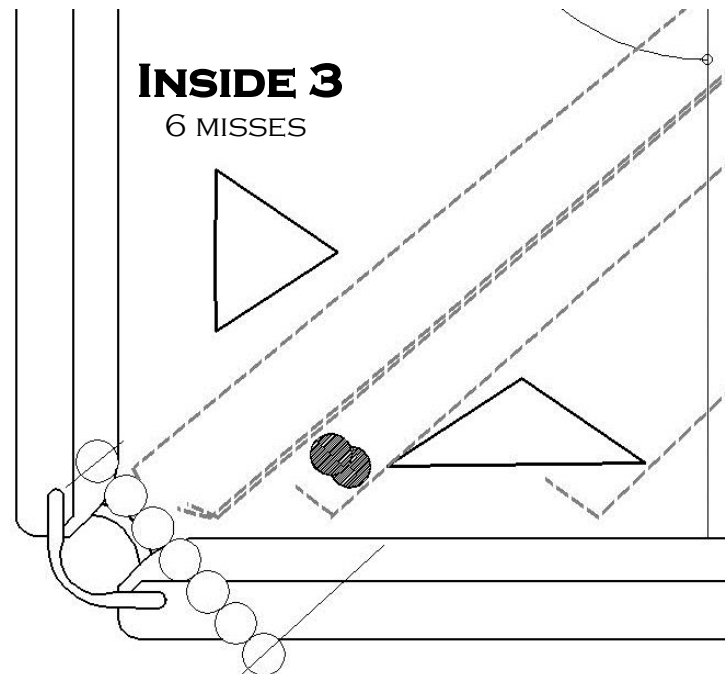
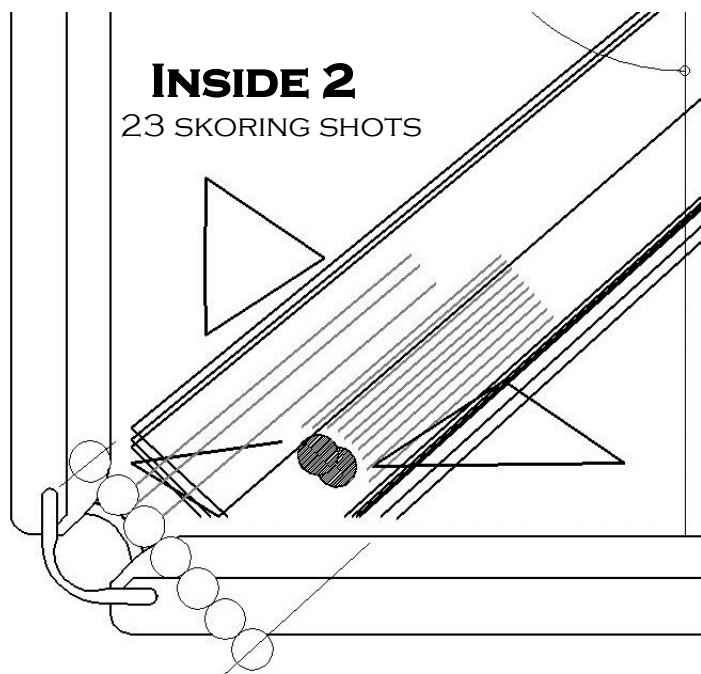

NEAR MISSES Shot 9 & 13 & 29 missed the direkt-cannon by only 1mm. Shot 20 & 24 were experimental. Shot 16 woz a bottom-jaw that missed (praps 9 out of 10 jawings miss), had i been less akurat i would hav got a cannon off the bottom-cush. Thusly the 20cannons kood eezyly hav been 26 cannons.

I had 6 trial-shots before the official 29shots to find what woz needed to best get the inside-cannon. All 6 shots skored but of course koodnt be counted in my 29shot trial. I had 29 proper shots koz there are only 30 lines on a page of my diary, & line 30 woz needed for writing the totals.

FAIR LEEVS My diary tells me that of the 23 skoring shots only 11 gave me a fair leev (or a good leev), & 12 gave a poor leev.

On Shot 26 i accidentally potted yellow in the left-baulk-pkt, az well az getting the cannon (a 4shot). In Shot 2 i got the cannon & then the qball fell in the right-baulk-pkt (a 4shot). Shot 24 missed koz the qball & yellow kollided near the mid-pkt (not shown), koz i woz experimenting by hitting yellow very thick & very hard. Before the kollizion the qball woz heading for the red, but would hav stopped short.

LUCKY ZONES (Inside 1 2 3 4) I show the lucky-zones from my earlyer chapters az a reference. Theze 2 zones belong to an outside-cannon, not our inside-cannon. Lucky-zones for an inside-cannon would hav a different size & shape & pozzy etc koz the qball iz attacking from nearer the mid-pkt. Anyhow, theze outside-cannon lucky zones help comprehension.

2 REDS (Dia2 3) I show 2 reds, koz for my first cannon the red sat near the apex of that lucky-zone (where shown), & later i gradually mooved the red 3 times & it finally ended up where shown. The red started off near what might be the apex of the lucky-zone for an inside-cannon, but then i decided to moov the red to block the side-jaw pathway. I found that i woznt blocking the jaw-pathway enuff, & hence i had to moov the red further & further.

6 BALL PATTERN (Inside 2 3) Az shown by the 7 balls, i managed to shoot a 6 ball pattern for 28 shots (ignoring the experimental Shot 20). The center of the pattern looks pretty perfikt (approx the red)(just lucky), but if it had been the center of the pocket it wouldnt hav spoiled my success-rate, i would hav gotten 2 or 3 bottom-cush cannons (instead of zero).

WHERE TO AVOID A VOID

VOID Shot 29 woz unlucky to miss. The qball missed the direkt-cannon by a hair, then rebounded off the side-cush & missed by a hair again, the red woz too far off the side-cush.

VOIDAGE The attack-angle for the bottom & side-cush cannon iz more acute than the attack-angle for the side-cush-cannon, & hence the red needs to be closer to the side-cush if i want to remoov that void . But if i placed the red closer such that neither type of cannon would miss then i would be reducing the width of the skoring pathway for the side-cush-cannon, & hence i would be reducing the overall-skoring pathway.

3 VOIDS Az detailed In Daly's Big Ball (on a pocketless table) there are 4 cannon pathways & hence 3 voids in the overall pathway if the ball iz far off the cushions. By mooving the red closer to a cush Daly kan reduce the size of 2 of them 3 voids to zero, leeving just 1 voids. By mooving the ball closer to the other cush Daly kan reduce the size of that void to zero, leeving no voids, & he then haz a voidless 8ball wide skoring pathway. If Daly then moovs the ball closer to a cush the 8 ball wide pathway gets smaller.

DALY'S TABLE On Daly's table the pathways are parallel & rebound-angle equals attack-angle. On my table the pathways radiate, & rebound-angle iz less than attack-angle. On Daly's table the 2 voids reduce to zero at the same place, without diminishing the 8 ball nett-pathway. On my table i kan remoov both them voids but at the expense of diminishing the 8 ball nett-pathway.

JAW-VOIDS A good akurat player hates voids near the red, near-perfikt shots are penalized. The worst voids are the jaws. The bottom-jaw pathway iz praps 0.4 balls wide, the side-jaw praps 0.6balls. About 1 in 10 jawings might yet yield a cannon if the red iznt sitting far away, thusly the jaws are 90% void. For theze 29 shots i tryd to remoov the side-jaw void by having my red closer to the bottom-cush. Thusly if i just-miss the direkt-cannon i get the inoff, no jaw in sight (except that some inoffs touch the jaw on the way in).

No Noo Nooo However in Shot 4 the qball hit the side-jaw (i hadnt mooved the red far'nuff) but luckyly i got a cannon. So i placed the red even closer to the bottom-cush. But then in Shot 9 the qball again hit the side-jaw (& zero cannon), so i placed the red even closer. But then in Shot 13 the qball hit the side-jaw (& zero cannon), so i placed the red even closer (i didnt get any side-jawings after that). I did suffer a bottom-jawing in Shot 16 (& zero cannon), but u karnt do much about that, u karnt remoov both jaw-voids.

GOOD PLAYERS Placing the red too close to the bottom-cush would partly block the inoff-pathway & reduce the overall-skoring-pathway (not good). Of course in a game the red sits where it sits, but for my 29 shots i wanted to place the red in the luckiest possible place. Now, the luckiest possible place for a good player iznt necessarily the same for a tyro. A good player haz a smaller shot-pattern, say 8 balls wide instead of 16 balls wide.

ZERO VOIDS I reckon that a good player might prefer smaller voids or zero-voids near the red even if this reduces the overall skoring pathway. We all hate allmost perfikt shots missing by a hair when a badder shot would hav gotten the cannon. I shot a tight 6 ball pattern. Thusly the jaw-pathways are more deadly for me than for a tyro who shoots a 16 ball pattern. If the jaw-pathways are 0.4 balls & 0.6 balls & total 1.0balls, then 1.0 in 6 iz a bigger problem for me than 1.0 in 16 for a tyro.

SIDE-JAW VOID By keeping the red closer to the bottom-cush (see the first 4 reds) i tryd to block all of the 0.6 balls of side-jaw-pathway (90% iz void), & in effekt replace it with a bit of side-cush pathway & bottom-cush pathway. Koz u might hav noticed in Inside 2 that by shooting a 6ball pattern i woz loozing at least 2 balls of bottom-cush pathway, & praps 1 ball of bottom&side pathway, & praps 1½ balls of side-cush, a total loss of 4½ balls.

0.5 BALL VOID As shown by the 5th red i kood hav mooved the red untill it woz direktly in front of the pkt, blocking 2.0 balls of inoff & jaw. The inoff-pathway iz 1.5 balls, & the kombined jaws & inoff iz 2.5 balls, blocking 2.0 balls leevs 0.5 balls (of 90% void) on one jaw or the other. A 0.5 ball void iz better than 1.0 balls of void, but 0.5 balls iz still a worry.

ZERO JAW VOIDS The 6th red iz closer in to the pocket such that any jawing would allways yield a cannon, thusly eliminating both jaw-voids. The red would havtabe no more than 1¼ balls kler of both jaws so that any qball sneaking past would touch the red while jawing out, if hit hard'nuff. I calculated that with the red az shown i would hav enjoyed 5.9 balls of cannon pathway (az shown) which would hav allmost accommodated that there 6 ball shot pattern that i happened to shoot. Anyhow, with hindsight, praps i kood hav konverted 4 misses to skoring shots lifting my tally from 23 in 29 to 27 in 29.

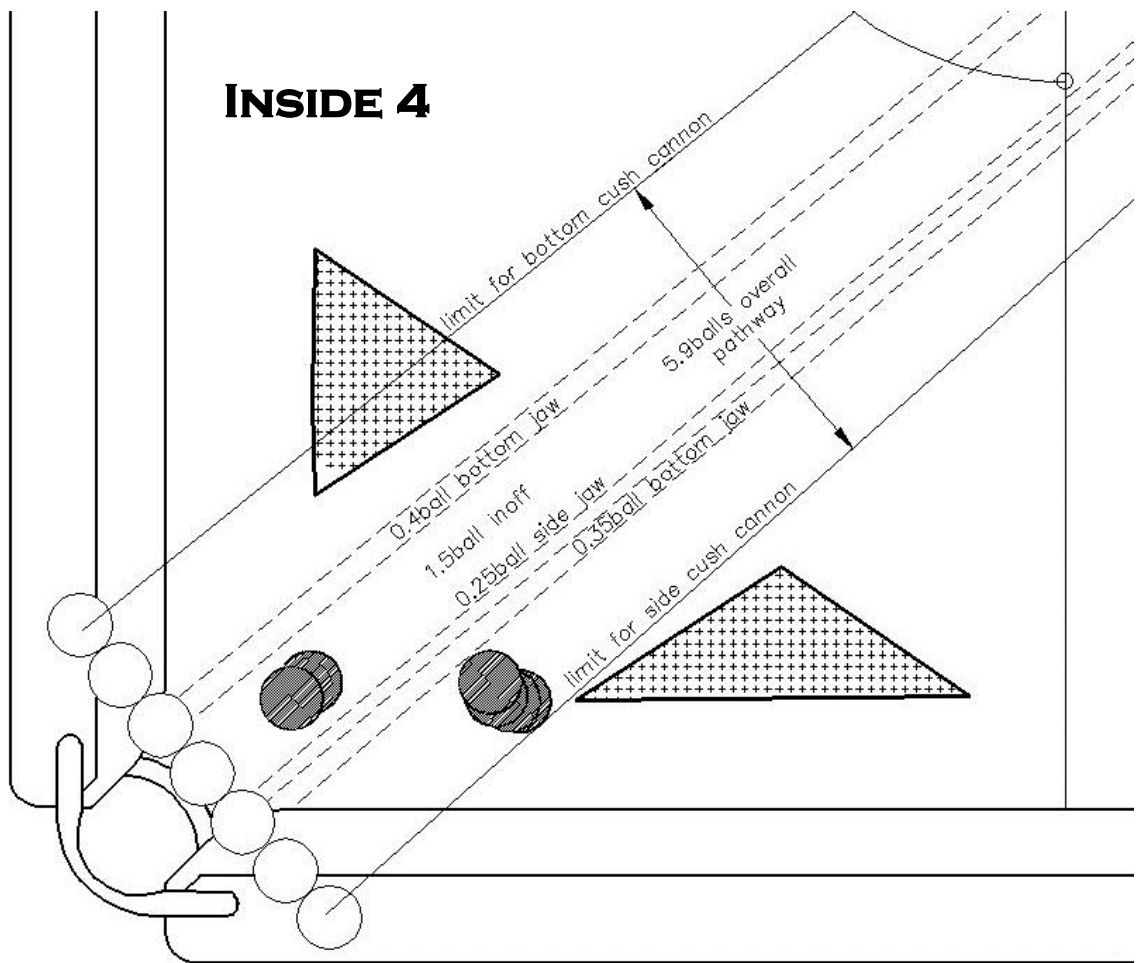

TABLE 1 RESULTS OF 29 ATTEMPTED INSIDE CANNONS.

number	qball									yellow				leev	
	bottom cush	bott & side	bottom jaw	inoff	side jaw	direkt	side & bott	side cush	stops short	pot yellow	kollizion	enter baulk	leev baulk	fair	poor
1						D						e	l	F	
2						D						e	l	F	
3						D									P
4					J										P
5						D									P
6				IO								e	l	F	
7								S				e	l		P
8								S				e	l		P
9					X							e	l		
10		BS										e	l		P
11						D						e	l	F	
12				IO								e	l		P
13					X							e	l		
14								S				e	l		P
15						D						e	l	F	
16			X									e	l		
17						D						e	l	F	
18		BS										e	l		P
19								S				e	l	F	
20								X				e	l		
21		BS										e		F	
22						D						e	l	F	
23								S				e	l		P
24											K				
25						D						e	l	F	
26								S		PY		e		F	
27				IO								e			P
28						D						e	l		P
29								X				e	l		
	0	3	0	3	1	10		6	0	1	1			11	12

20 cannons in 29 shots plus 3 inoffs makes 23 scoring shots in 29, or 79.3%.

Cannons off side & bottom are not possible when the red iz near the lucky-S-zone.

6 misses inklooded 1 kollizion, 3 shots went too narrow, 2 went too wide.

Shot 26 -- the pot-yellow woz into the left baulk-pkt – got the cannon but