

REBOUND ANGLES

CUSHION-FIRST CANNONS

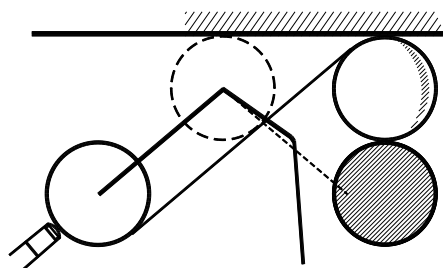

Cushion-first cannons are often the easiest way of keeping a run going. Here we look at a few hints for judging the correct aiming-point on the cushion. There are a couple of traps.

CUSH-FIRST 1 In pozzys like this, the cushion-first-cannon (shown) can be a less risky sequence than a direct

cannon. Here the yellow is frozen so, we know that aiming to graze the left-edge of yellow results in a thickish contact on the right-hand-edge of yellow, & the qball then cannons nicely on red. According to most theoreticians, practitioners, & authors, the qball's rebound-angle equals the attack-angle. So, aiming to graze the left-edge of the yellow should result in a graze on the right-hand-edge, after rebound. The qball should follow the broken line. But, the actual rebound-angle is less than the attack-angle, & the actual rebound is as shown by the solid line. Anyhow, I measured the rebound-angles on the right-hand top-side cushion of my home table, & I got the following results. A ball with pure rolling was played very slowly onto the cushion at various attack-angles (against the nap). The stopping places were measured to allow calculation of the rebound-angles, shown here.

Attack	10	20	30	37	40	50	56	60	70	80	86	90
Rebound	5	12	22	30	33	46	53	59	71	82	89	92
Gain	-5	-8	-8	-7	-7	-4	-2	-1	1	2	3	2

The loss is greatest when the attack-angle is between 20° & 30°. Rebound equalled attack at 65°. Rebound was actually larger than attack at attack-angles over 70°. But cushions vary. Some have a newish cloth covering & hence slide, the loss in rebound-angle is unbelievable. Some cushions are old & worn (or high), in which case the loss would be very little.

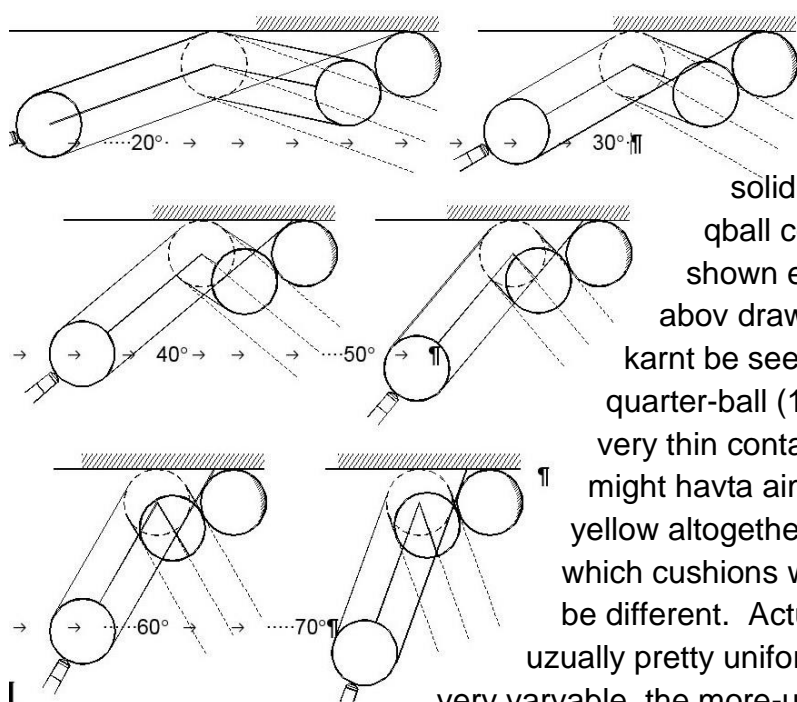

CUSH-FIRST 2

These drawings show the results of aiming for the left-hand edge of the yellow. The broken lines show rebound-angles equal to attack-angles. The solid lines show the actual rebound-angles (& the qball contact on yellow) based on the table of results shown earlier. Contacts on yellow, measured from the above drawings, are shown at the bottom of the page. As can be seen, for narrow attack-angles, you might have to aim a quarter-ball (16/64ths) wider than you might think, if you want a very thin contact on yellow. And for attack-angles over 65°, you might have to aim a little inside the yellow, or you might miss the yellow altogether. These are the results on my home table, which cushions were neither slippery nor old. Your table might be different. Actually, I should add that new & old cushions are usually pretty uniform. Whereas medium aged cushions are usually very variable, the more-used sections acting like old cushions, & the less used bits acting like new cushions. Some players don't know what bit they

Attack Angle	10	20	30	40	50	60	70	80	86	90
Rebound Angle	5	12	22	33	46	59	71	82	89	92
Gain in Angle	-5	-8	-8	-7	-4	-1	1	2	3	2
Contact (64ths)	18	16	9	4	1	-1				

CUSH-FIRST 3 The broken qball iz in perfect pozy for a cushion-first cannon, ie **2 BALLS WEST** of the yellow. We can aim for the edge of the yellow with zero side to get a cushion-first cannon. The contact on yellow haztabe very thin koz the red iz a little east of the yellow. Here, aim meens the qball edge line, not centerline. With the qball **1 BALL WEST** of yellow we can get the same rezult by aiming to hit the cushion at the same point az we did for the 2-ball pozy, but with a little rhs. This meens that we havta

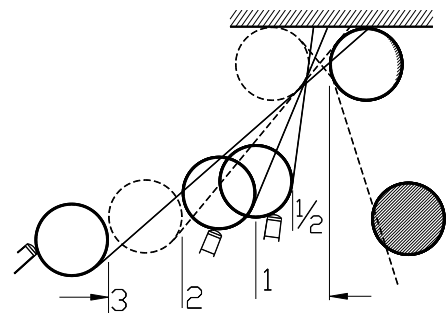

aim wide of yellow. Koz if u aim for the edge of the yellow (with zero side) u will get a thin touch on yellow but u will miss the red (mainly koz the red iz a half-ball east of yellow). Theoretically we could aim say 2mm wide of yellow (with zero side) to get a thinner graze on yellow, & praps just get the red, but this would hav given very little margin for error. Aiming wide with rhs is more forgiving. With the qball only **A 1/2 BALL WEST** of yellow we can get the same rezult by aiming to hit the cushion at the same point az we did for the 2-ball pozy, but with maximum rhs. This aiming point feels very wide. Uzing zero side cannot possibly giv a cannon in this pozy, no matter how thin u get yellow. With the qball **3 BALLS WEST** of yellow we can try to get the same rezult by aiming to hit the cushion at the same point az we did for the 2-ball pozy, but with lots of lhs. This aim iz well inside the edge of yellow. The lhs (check-side) theoretically givs the qball a squarer rebound-angle (ie larger than the attack angle), identical to the 2-ball west case (& identical to the 1 ball & 1/2 ball cases). **SUMMARY** Cush-first 3 shows all 4 shots hitting the cushion in the same spot, & getting the same rezult (the thin cannon) by virtue of side-spin givng each shot the same rebound-angle (except that we hav zero spin for the two-ball pozy). This iz a good little trick to know. But there iz one little problem trap. Unfortunately, the 3-ball west case duznt work. Koz, check-side haz almost zero effect on rebound-angle when the attack-angle iz less than 50°. This trap needs investigation. So in the next section we look at some tests uzing check-side.

EFFECT OF CHECK-SIDE

Here we look at some test rezults for cushion rebound uzing check-side.

The following table repeats the test rezults for pure rolling.

Attack	10	20	30	37	40	50	56	60	70	80	86	90
Rebound	5	12	22	30	33	46	53	59	71	82	89	92
Gain	-5	-8	-8	-7	-7	-4	-2	-1	1	2	3	2

In a second series of tests, we repeated the rebound-angle tests, but hitting the qball with maximum check-side. The following table shows the test rezults, & the gained-angle. The Nett Gain iz the gain attributable to uzing check-side, ie the gain over & abov any gain that u would hav got uzing zero-side (pure-rolling).

Attack	10	20	30	37	40	50	56	60	70	80	86	90
Rebound	8	13	19	24	28	46	56	66	91	114	124	127
Gain	-2	-7	-11	-13	-12	-4	0	6	21	34	38	37
Nett Gain	3	1	-3	-6	-5	0	2	7	20	32	35	35

PURE ROLLING The first table indicates that, for pure-rolling, the rebound-angle only equal the attack-angle at about 66° (Hemming would say that reflection equals incidence). At lesser angles there iz a loss, & the loss iz a maximum (-8°) at 25°. At larger attack-angles there iz a gain, & the gain iz a maximum (3°) at 86°.

CHECK-SIDE The second table indicates that, for check-side, the attack-angle & rebound-angle are equal at about 56°. And below 50° check-side iz actually counter-productiv. And check-

side duz not really start to justify its use until the attack-angle iz over 55°. Anyhow, this mostly contradicts the skoolkid theory that u mostly kum across.

It should be sed that all theze tests were done at slow pace, the ball uzually rolling say 400mm. Also, theze tests were done off a side cushion (ie against the nap). The pace in the tests woz a little faster than the pace at which u would play most close-cannons, & much slower than the pace at which u would play the average snooker or billiard shot. I havnt yet done any tests at very slow pace or medium pace or high pace (but i hav repeated my tests off other cushions).

One shouldn't make too much of theze ruff tests & figures. **CUSHIONS VARY**. The cushions in the tests were not new & therefore not very slippery (i am talking about the cush-cloths). Logically a new slippery cush-cloth would giv different rezults.

Of course, **RUNNING-SIDE** iz a different kettle of fish, & i will havta do some extra tests. But there iz little doubt that running-side haz no surprizes for us, so i am in no hurry. **CUSHION CRAWLERS** are interested in the bits of the abov tables between an attack-angle of 30° & 60°. Az kan be seen, for pure-rolling, the rebound-angle in this zone iz always a little less than the attack-angle, & check-side givs almost zero nett gain.

CD LOCOCK SIDE AND SCREW 1901

This iz the 2nd most sensible book u kan find on the physics of billiards.

.....Cushion Angles -- There is a popular fallacy to the effect that when a ball, played without 'side', impinges on a cushion, 'the angle of reflection is exactly equal to the angle of incidence'. As a matter of fact this is very rarely the case, the divergence of the ball from its predicted path depending on its own rotation and pace, and on the nature of the angle of incidence.

..... Mr Hemming states that the line OF fairly represents the path of the ball if struck with No 3 strength and perfect rolling, provided that the angle EOP is not very large. He finds that the angle of reflection is abnormally increased by (i) increase in the angle of incidence at a strength below No 3, and (ii) 'follow' on the ball : while the angle of reflection is diminished by (i) high velocity at a small angle of incidence, and (ii) defective rotation, or drag.

.....Side-Effect on Cushion Angles -- The most obvious effect of side is the alteration which it produces in the angle of reflection from a cushion. This effect is most marked when the cushion is played at directly (at an angle of 0°), when a varyation of 25° or so is easily produced. At oblique angles the effect of side away from the cushion is to increase the angle of reflection, so that the ball travels closer to the cushion.

When side towards the cushion is put on, the angle of reflection is generally diminished, but when the angle of incidence is about 45°, the angle of reflection seems to be almost unaltered by cushion side -- at any rate, in the case of gentle strokes.

.....A fact that is quite unknown to the ordinary player, and even to many good players, is that a cushion may impart side to a cue ball or an object ball. On tables with very fast cushions made of soft, yielding rubber, the amount of side which under certain circumstances may be communicated to a ball by a cushion is often very noticeable indeed; especially is this so if the cushions have a very sharp nose.....

..... Nowadays all good tables, instead of being fitted with moulded rubber cushions (which sooner or later get very hard) are fitted with cushions built up of strips of very yielding rubber, and on all such tables the eccentric angle at which a very fast ball rebounds after striking a cushion at no great angle, has to be reckoned with.

.....In certain positions, this fast-ball eccentric angle is of the greatest assistance in keeping a ball out of baulk when playing an in-off. In fact, it is not too much to say that many a stroke which, played on a table with hard cushions, sends the object ball into baulk to remain there, would, if played in exactly the same way in a table with very yielding cushions, not only not send the objectball into baulk, but actually keep it in the upper half of the table.....

UZING THE MIRROR IMAGE CUSH-FIRST 4

In Cushion-First 1 & 2 & 3 we looked at aiming points when the yellow woz frozen. In Cushion-First 4 the yellow iz off the cushion (¼ ball).

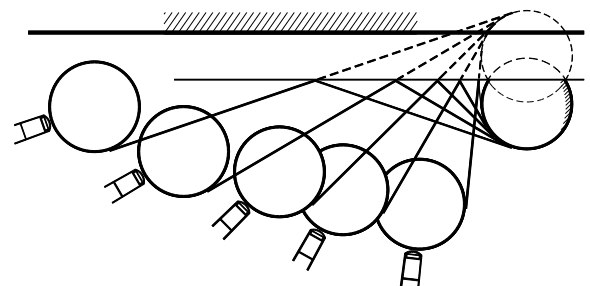

GEOMETRY If the cushion rebound-angle iz the same az the attack-angle u kan uze geometry to judge the aim. And, if it iznt, u kan uze geometry to help to judge the aim anyhow. Imagin a **MIRROR** standing with the silver-line of the mirror parallel to the cushion & passing throo points that match the center of the qball frozen on the cushion. Now, if u want to hit the yellow **DEAD-CENTER** (cushion-first), just aim for the center of the imaginary mirror-image of yellow. Right? Well, Yes & No. Koz u karnt hit the dead-center of the yellow unless the real yellow givs u a clear path to the dead-center of the imaginary yellow. But i am getting off the track. If we want to say **GRAZE** the real yellow, we aim to graze the imaginary yellow. Then, we re-aim to allow for reality, ie that rebound duznt equal attack. Simple. I uze this mirror technique to help me for **LONG DISTANCE** strokes, such az cushion-first loozers & cushion-first cannons from the Dee. But it duznt help me much in **CLOSE-CANNONS**, u are much better off just uzing feel, forget the mirror. I don't know why i even bothered mentioning it. This reminds me. The **CUSHION-LINE** in my drawings iz not the cushion face. Koz when the real ball sits against the real cushion it sits partly under it, & so the back of the ball iz actually 1mm behind the face. But in my drawings the cushion-line iz always the effectiv cushion so to speak, ie 1mm behind the actual face of cushion. The qball **SLIDES** along the cushion befor rebounding. Soft nursery cannons might suffer 3mm of slide along the cushion. That's a lot. Praps i should redraw the qball trajectories to show the penetration into the cushion & the slide along the cushion. But then i would havta firstly recalculate (inkreec) my mezured rebound-angles, so i would be back where i started. I think i will leev things az they are for now.

CUSHION-FIRST AIMING POINTS

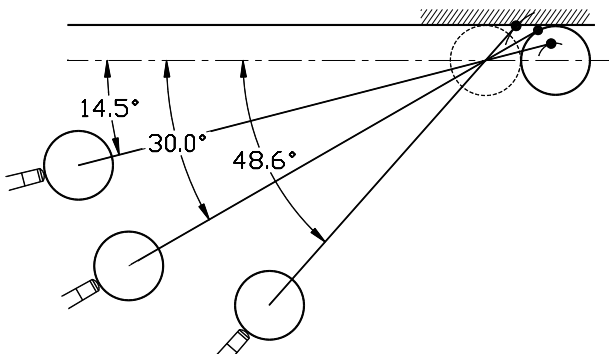

CUSH-FIRST 5 To hit the cushion & frozen yellow at the same time u need to aim at the **DOTTY BALL**. If u aim left of this ball u will hit the cushion first, & if u aim right u will hit the yellow first. The drawing shows **3 PRIMARY AIMING POINTS**. If the qb lies on a 30o angle from the dotted ball aim ½ ball on yellow. For 15o aim ¾ ball. For 49o aim ¼ ball.

To help learn aiming-points place a spare ball where the dotted ball is drawn. Then move the qb around to various angles, especially the 3 primary angles mentioned, & this will show u the needed contact for any angle from 00° to 90°. It might even help during play to visualize the above **PHANTOM BALL** touching the yellow.

If u hit the ball & cushion at the same time, u won't **POT THE YELLOW**. U havta aim a bit thinner coz of ball-to-ball friction. U can experiment to see how far in advance u havta aim/hit a frozen red to pot it along the cushion. If u place the yellow on the cushion say **5MM** in advance of the red & hit the yellow full-ball, from any qb position in question, u will find the gap that works. This needed gap will increase with strength. It is sometimes over **10MM**. Joe Davis said that a bit of **RUNNING-SIDE** on the qb helps these frozen pots. Some players say that the running-side helps coz the transmitted side makes the pocket larger, i don't agree. U can test this sort of stuff by using a **STRIPED POOL BALL**. Lay it against the cushion with the stripe parallel to the cushion. See what happens to the orientation of the stripe when u (a) pot it without using any spin, (b) pot it by hitting a frozen ball 5mm or 10mm from the pool ball, (c) pot it using a little running-side, (d) pot it using a lot of running-side, (e) pot it using wrong side. Weird things happen, or don't happen.

Billiards Arithmetically Treated includes a **COMPUTER PROGRAM** for ball rebound from a cushion. This program calculates (a) the rebound-angle, (b) speeds & (c) spins during any time during the impact event. Also (d) the total impact time, & (e) the penetration into the cushion, at any time. Strange stuff happens. In addition, it calculates & draws (f) the ball's final trajectory, ie after table-skidding has stopped, ie when the ball is rolling happily, plus (g) the final speed, & (h) the final spin. The program calculates the energy losses due to (i) cushion bending, & (j) due to ball-to-cushion skidding, & (k) during ball-to-bed skidding, & (l) due to jumping. The program needs to know (1) the cushion height & (2) the cushion resilience, & (3) the ball-to-cushion friction, & (4) the ball-to-bed friction. It needs to know (5) the ball size & (6) the mass, & (7) the initial speed, (8) angle, (9) spin & (10) topspin (or screw). The program also draws (m) the ball trajectory inside the cushion (ie the slide). This gives an indication of how far a qb might need to hit a cushion in advance of a frozen ball, when u wish to pot the ball, but the program itself doesn't deal with potting, it only deals with clean simple rebounds.

DIZZY'S ADVENTURE

CUSH-FIRST 6 The red iz a bit too far east & the cushion-first cannon iz possible. So iz the yellow-first cannon with rhs, but there iz a trap. **6A** Dizzy decides to play the thin yellow-first cannon. She aims very thin on yellow so that it duznt go too far east.

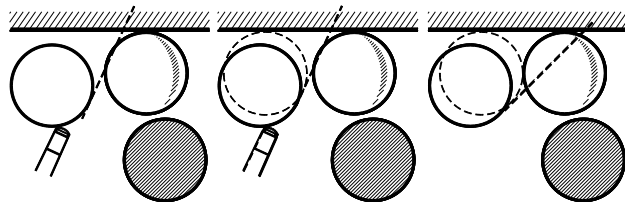

But, u should see her face when the qball hits the cushion first, then hits the yellow thickish, & misses the red by a mile. What happened? **6B** Here the broken ball shows where Dizzy's qball hit the cushion. A hell of a long way before the yellow. She would hav gotten the cushion-first even if she aimed a little thicker. And the rhs rezulted in the qball hitting the yellow thickish. And then it missed the red. It might hav missed even with zero side. **6C** Here the broken ball shows the aim needed to hit the yellow & cushion at the same time. This aiming point iz thicker than a quarter-ball. So, if Dizzy aimed a little thicker than this, a little thicker than $\frac{1}{4}$ ball, to get her yellow-first cannon, the yellow would hav gone a long way east. Dizzy would hav gotten her cannon, but the leev would hav been bad. So, in this pozzy, a yellow-first cannon iz hopeless.

6D Az mentioned much earlyer, when the yellow iz frozen, if u aim to graze the lhs (az shown) the qball will hit the cushion-first & then it will graze the rhs of the yellow (not shown). At least it duz if the rebound-angle equals the attack angle. Dizzy obviously duznt know about this handy Mirror-Image

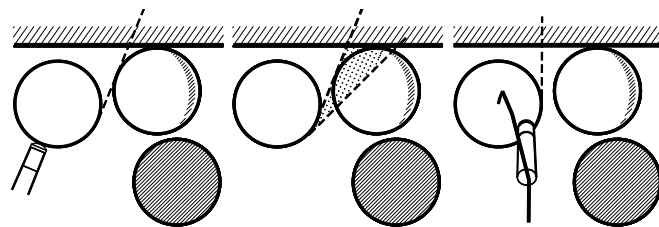

Rule. **6E** This shows the no-woman's-land. If Dizzy aims inside this zone (or anywhere left of this zone), she will hit cushion-first. Az can be seen, there iz about 25° of no-woman's-land, where u karnt score a cushion-first cannon in this particular arrangement of the balls. It's hard to believe with the ballz so close & inviting. Moov the qball a little right (not shown) & the no-woman's-land shrinks very quickly. Moov the qball to the left (not shown) & the no-woman's-land shrinks quickly az well, for scoring. But, the no-womans-land for a score plus a good leev iz always larger than the no-womans-land for just the score. **6F** Az not shown, it might be possible to get the cushion-first cannon by aiming further left, & uzing rhs. Here in 6F we show a shot with swerv (& side), aiming praps square to the cushion. This certainly obviates the missed cannon. But it iz not an eezy shot when the qball iz this close to the cushion, u might foul. Chalk-up. And mind the foul.

CUSH-FIRST 6G Dizzy should hav played the direct thin-thin cannon, az shown. It's a **THINALONG**.

