

MACKA'S TURNABOUTS

We are nursing rt-to-left along the topcush (left-handed), & near the left toppkt we turnabout & then nurse back the other way (now on our good hand). All of the turns & turnabouts in Ch51 52 53 54 55 & 56 were drawn at the rt-toppkt, & now we will use mirror-images at the left-toppkt. Plus I draw some new turnabouts (some are for thrillseekers).

HUTT NEWS 4 MAY 1932 BILLIARDS SENSATION

*Clark McConachy has made the greatest sporting gesture of the century in the world of billiards, writes a correspondent in an English paper. Having made a world's record of **297** close cannons, he sets aside all personal kudos, and states bluntly that his record proves the need for further limitation of close cannons "in the best interests of English billiards." He is right, but he alone could make an effective stand for the change he advocates. His position as record-holder places him above all criticism on the grounds that he wants to eliminate what he cannot execute. The "turning movement" he sprung on at Thurston's is creative art of the highest order; the game has never seen a more beautiful example of glorious ball-control. It is as far removed as anything can be from some of the perpetual scoring methods of the past, which called for no great skill to pile up points when once a set position was attained. McConachy's manoeuvre is nothing like the above. He tells me he has worked out five or six different methods by which he can execute his "turning movement". In one instance with the cue ball he plays a shimmering shot which barely brushes the first ball, sends his ball to the side cushion and brings it back on the second object ball to leave ideal cannon position in a new cushion direction. Control of the first object ball is the secret of the "turn." McConachy plays a fullish shot-on that ball which brings it back off the side cushion clear of the second ball and completes the cannon with such delicate precision that his ball runs on far enough to stop beyond the ball which comes away from the cushion, thus offering close cannons again all along the top cushion. Both these movements, and others more complicated are only of playing interest to six professionals at the most, a point which must be kept clearly in mind when limitation is discussed. Amateurs are not interested — the whole problem is outside their playing capacity. Very few indeed of them can nurse the balls past a corner pocket in the usual way; McConachy's turning movements are something far more advanced and utterly beyond the amateur game...*

TURNABOUT AIM POINT

MACKA 1A In Macka 1B we want to play a cushion-first turnabout, landing halfball on the yellow (CYR). To help judge the needed aim we stand well back & hold our cue midway tween the yellow & the qball with cue laying parallel to the topcush (not shown). The cue points at the needed aimpoint on the face of the sidecush. We shoot at that point & score the cannon ok. Macka 1B doesn't show the 1A method, but the trajectory shown in 1B is the trajectory needed/obtained for 1A. 1B shows a slightly different method, but near'nuff the same trajectory.

MACKA 1B U kan uze the 1A method for every such cush-first turnabout cannon. But there iz a **UNIVERSAL COMMON AIM POINT** for that kind of turnabout. Uzing that aimpoint works for every such turnabout, if the balls are sitting in about the proper area. Stick a blob of **BLUETACK** on the back of the rail (not the face of the cush) so that aiming at the bluetack givs a halfball kiss on the yellow (az shown). Now play that cannon after mooving the qball a little north south east or west. That there bluetack turnabout aim-point still yields a halfball kiss on the yellow. There iz no need for the parallel cue method uzed in 1A. **END OF BRASS** The rules don't allow bluetack, but when shooting at the bluetack the right-hand edge of the qball iz heading for the left-end of the brass of the pocket. This brass-end iz your secret guide, just aim a halfball left of the brass. This works for any sensible pozzy of the qball & yellow, but aim a bit left or right if the yellow iznt 3-balls klear from the sidecush (or if the yellow iz not frozen). Nothing kan stop u now. And i just noticed that the left edge of the qball touches the J-Spot.

IF the qball might catch the jaw/undercut then u will get JYR (not good) So aim for the flat & uze rhs to get CYR. **IF** the red blocks your aim then "just miss" the red & uze rhs. **IF** the red iz level with the yellow then u will hit the red befor the yellow, so play softly. **IF** the red & yellow are sitting a mile away from where shown then the brass will be an initial guide only.

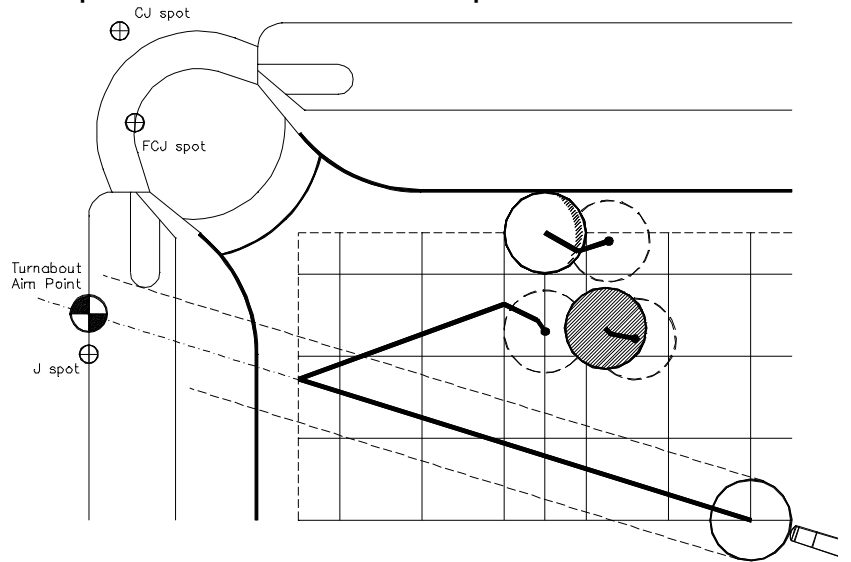

THINALONG TURNABOUTS

Thinalongs are one of the friendliest ways of nursing rt-to-left on your wrong hand, & thinalongs are also very friendly for setting up a turnabout. TurnAbouts 10 & 11 in Ch53 show moovs for setting up a turnabout near the rt-toppkt. Below, Macka 2 & 3 show mirror-images of 10 & 11 for the left-toppkt.

MACKA 2 Here u kan play to place the yellow & red wherever u want. And u want to leev the qball well south for the turn. U uzually bump the yellow ahead of the R, but here u havnt hit yellow thicknuff. Anyhow u now hav a choice of a number of turnabouts. **MACKA 3** Here u hit cush-first (CYR) with lhs to get a thick kontakt on yellow & thin on red. Or u kan play yellow first (YCR). The uzual stuff-up iz to get the red too thick. Az uzual the qball needs to finish well south.

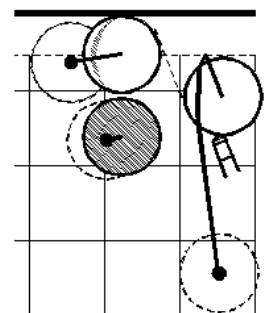
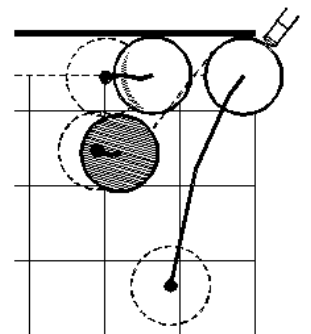

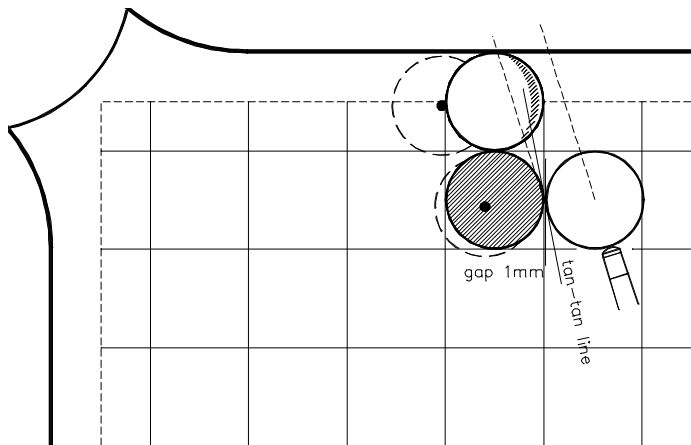

MACKA 4 Here u hav three options for setting up a turnabout, (RYC), az shown, or (YCR) using lots of lhs, or (CYR) using lots of lhs & swerv. We show (RYC). There are 5 varyables that affect which of the three options will work ok & whether u need a thin or thick kontakt & sidespin. (i) The YR angle might be less than 90dg (good)

or more than 90dg (bad). (ii)

The Y might be frozen (good) or

(iii) The R might be touching Y az

1mm or 2mm or more klear.

shown (bad)(R gets kissed out by Y) or the R might be 1mm or 2mm or more klear (better). (iv) The qball might be the same dist from the topcush az R (az shown)(good), or it might be closer (good) or farther (good). (v) The qball might be 1mm klear of the R (az shown)(ok), or 2mm or more (better).

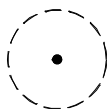

Me myself i look at two more varyables.

(vi) The gap tween the qball & the YR tangent-tangent line (1mm here).

(vii) Where the QR tangent-tangent-line kuts the Y (1/3ball here).

These seven help me decide (for any thinalong pozzy) how best to set up the turnabout. If things don't look good then i play some more thinalongs to improov, before i jump. But if in Macka 4 i were to moov the qball east (not shown), i would play (YCR) with lhs (not shown).

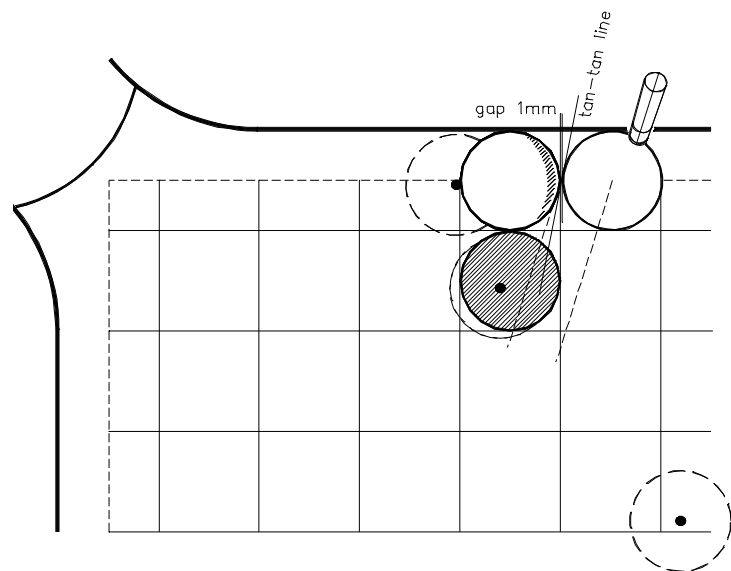

MACKA 5 Here the Y & R are in Macka 4 pozzy, but the qball iz frozen 1mm klear of the Y. If we shoot away from the topcush playing a YR cannon (to set up a turnabout next shot) we will get a surprize, we will hit the R too thick & the R will go too far out & too far ahead. Hitting the Y thicker wont help. **PIQUÉ** So, we jackup 45dg az shown & play thin on the Y with soft piqué to drive the Y ahead, while hitting the R thin, leeving a friendly turnabout next shot (not shown). The

main danger iz missing the R. **CREEP OUT** A safer option might be to creep out, playing a very soft YR cannon (not shown), barely getting to R, leeving a **MACKA 4** kind of of pozzy.

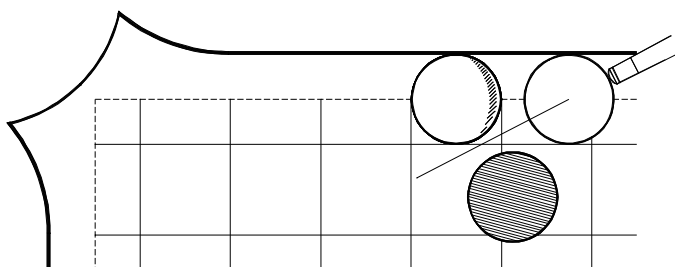

MACKA 6 YELLOW GOT AHEAD TREFOIL PRAKTIS DRILL This kind of pozzy iz a good praktis drill for experimenting to set up & get a good turnabout.

YELLOW GOT AHEAD THINALONG SOLUTION

MACKA 7ABCD When the Y is a 1/2ball ahead of R (a 1/2ball underlap)(as shown) a thinalong turn is still possible.

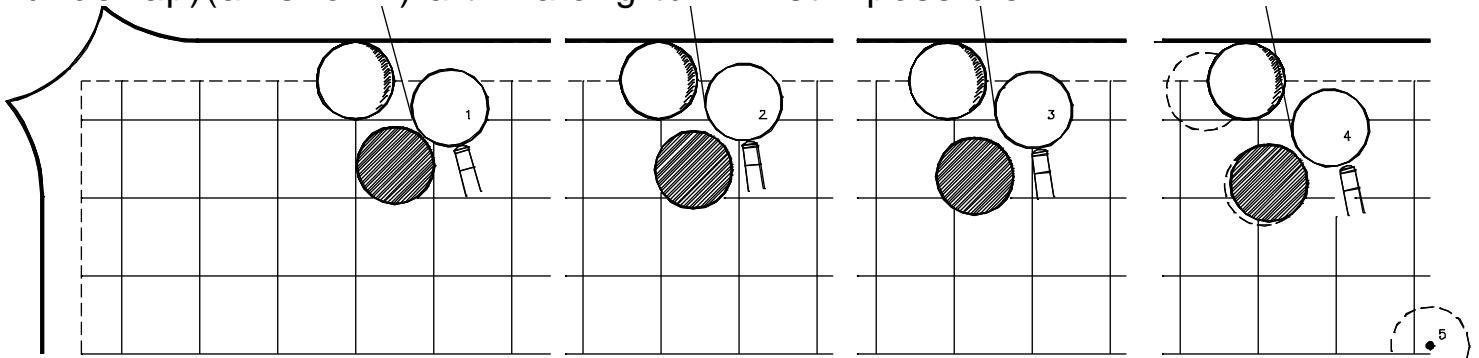

AZ SHOWN you play a few little (CYR) tickles & miraculously the R underlap gradually reduces from 1/2ball to praps 1/4ball, & now u can go for it. A 1/4ball underlap can be reduced to 1/8ball if u want, but don't go there, koz every time u tickle the R it goze further south, & in 6D the R is already far south. Reducing the underlap is half the battle, but the other main thing is that in 7D u hav the qball sitting close to the Y as shown (i mean that u hav the qball sitting well west). In 6D u play (YCR) thin on Y, grazing the R on the way out, the qball finishing well south (as shown). A little rhs might be needed (as shown). **REMEMBER** U need to leev the Y at least 1ball ahead of the R. As shown i managed to get it about 3/4ball ahead, not ideal. **7D** If u are not happy then it might be best to sneak-in one more little cannon as in 6C befor jumping.

YELLOW GOT AHEAD SLIPTHROO SOLUTIONS

MACKA 8ABCDE U play a sliphthroo & back. Slip throos are a midcushion turnabout but here the sidecush is there if needed.

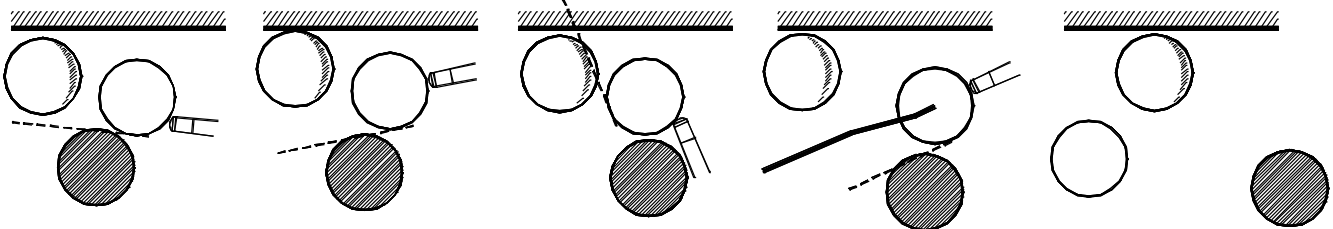

Sliphthroos are not eezzy, the main problem being the gather needed in 8E. Luckily near the pkt the sidecush can help save the day (see Macka 9).

MACKA 9 Instead of slipping well throo u stop short & use the side cush as shown. Aim a bit right of the J-Spot to hit the Y a thick halfball. Actually in 9 the R is too close to the cush & the kissoff off yellow might miss the red. This is coz u played the eezzy sliphthroo without thinking ahead. **MACKA 10** U hav opened a big gap

tween Y&R. Then here u skrew from Y to R, sending the Y at the FCJ-Spot. Y returns & sits next to R as shown. **I LOVE IT.** When Y is close to the corner & frozen the FCJ Spot is nearnuff on a line throo the visible edge of the top jaw. Shoot Y at jaw edge & it returns to where it woz.

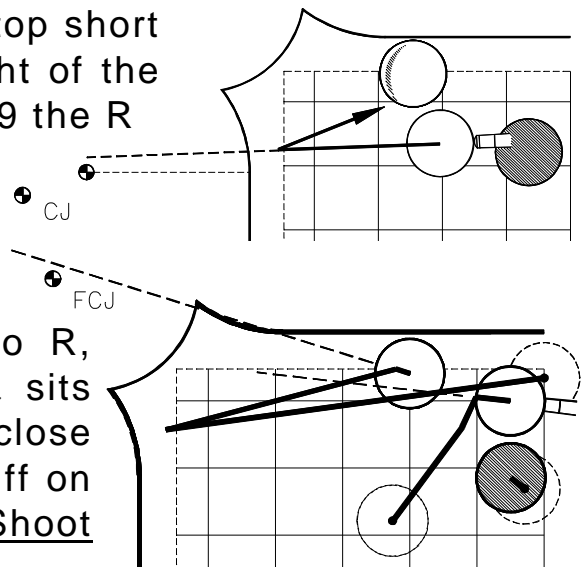

Warning No1. The qball needs to leev room for the Y to get past.

Warning No2. When stunning the Y the extra ball-to-ball friktion trys to send the Y a tad outside the edge-of-jaw (especially so at soft pace).

Warning No3. If the qball & Y are both hardup & close together then u karnt send the Y at the edge-of-jaw. The Y will hit CJJ (frozencush-jaw-jaw) & head off down the sidecush (goodbye Y). Uzing left-sidespin (on the qball) might help, it throws the Y wider (& the tranzmitted rhs given to the Y helps the Y to get a wider rebound off the topcush too).

Hint No1. If the qball iz well off the cush u might havta kontakt the Y rt-of-center to send it towards the edge-of-jaw.

Hint No2. If the qball iz on a certain angle u will hav the luxury of both options, left-of-center on Y, & rt-of-center.

Hint No3. U might prefer to skrew to inside the R to form an ivory-wall to block the returning Y az shown in **MACKA 11**. This might improov the pozzy in some way. For example if u skrew well back inside the red the Y might kum back to sit level with the R (it woz initially ahead of the R), & then u might do your favorit thinalong-turnabout.

Hint No4. If Y iz more than 3mm off the topcush (instead of frozen) then u need to shoot it a tad inside the edge-of-jaw. (This iz the exakt pozzy shown in Macka 9).

Hint No5. If the Y iz hardup but a longish distance from the corner then here too u havta shoot it a tad inside the edge-of-jaw. In fakt i play this when near midcush (az a re-gather rather than turnabout), in which case i havta shoot the Y well inside the edge-of-jaw (ie i havta uze the real FCJ-Spot).

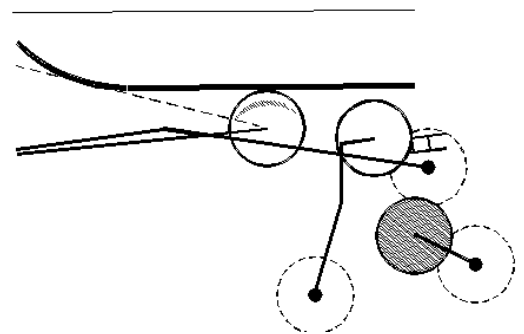
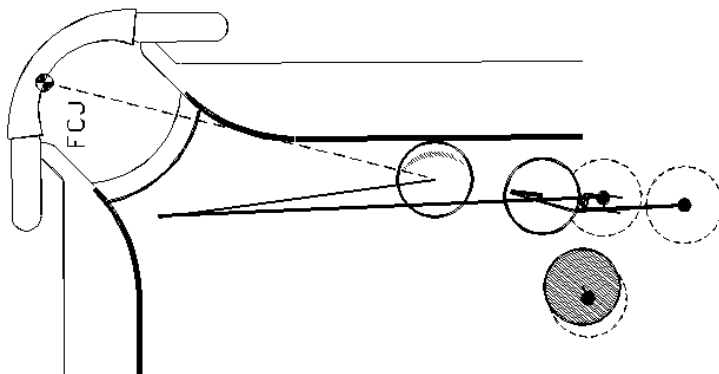

MACKA 11 (SEE CH41) **MACKA 12** (SEE CH41)

MACKA 13 (SEE CH43)

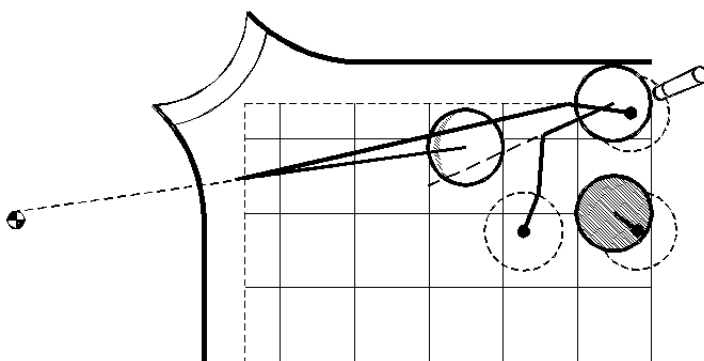

Similar to Macka 9 but sending the Y at the J-Spot. This shows a piqué sort of shot, but if the balls are closer together & nearer the sidecush rolling iz uzually ok. Mostly u don't uze the J-Spot for a turnabout, u uze it with an ivory wall, to improov (in which case u

will need that there piqué to keep the Y quieter). Piqué allows a soft action (otherwise the Y returns too hot).

PYRAMID AIM-SPOT TURNABOUT

I found a new turnabout & a new aim-spot

CH41 CORNER J-SPOTS shows 6 aim-spots (& 6 mirror-images) at the 4 corner pockets. These aim-spots result in a ball hitting the jaw(s) & (i) returning to where it started, or (ii) rolling along one cushion, or (iii) rolling along the other cushion. The Pyramid Aim-Spot (shown) makes a ball (iv) jaw out & roll towards the pyramid-spot.

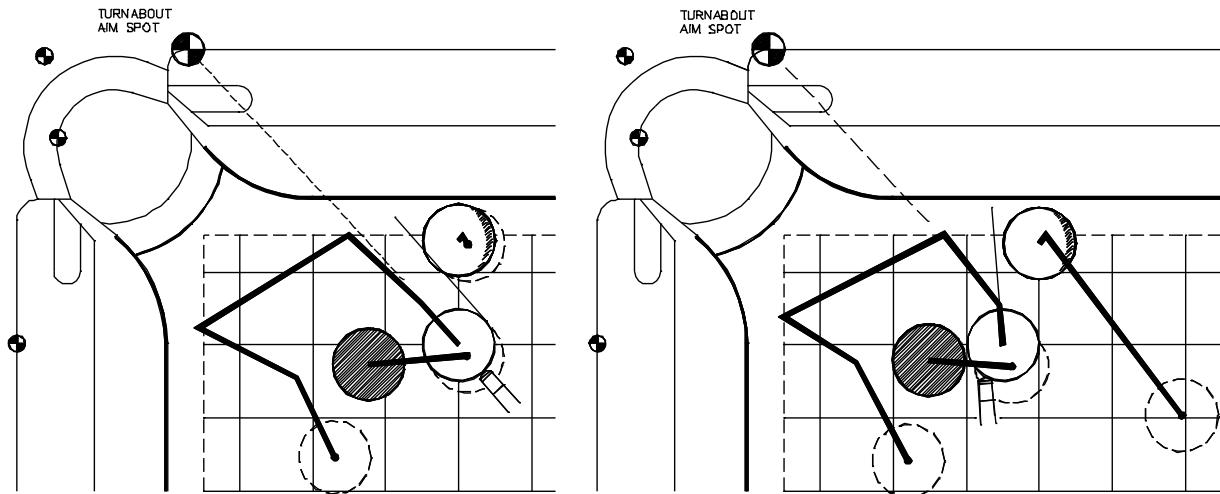

MACKA 14 & 15 U play on the Y such that the qball rolls towards the Pyramid Aim-Spot. The qball hits the topcush near the topjaw, then hits the sidejaw, & then rolls towards the pyramid-spot. The qball cannons on the R, which iz sitting on or near the qball's path to the pyramid-spot, & with just a little luck u get a nice turnabout (az shown).

FINDING THE PYRAMID AIM-SPOT Hit the qball softly onto the topcush near the end of the topjaw, untill u find the aim-line where the qball hits the sidejaw & then travels slowly towards the pyramid spot. The Pyramid Aim-Spot iz at the junktions of all such aim-lines. **TOPJAW** The aim-spot wont apply if the qball catches a bit of the topjaw, alltho u can make an allowance here (for minor infringements). **IMAGINATION** There are a myriad of pozzys where a (YCJR) cannon can save the day. Uzing the jaws sounds fraught, but when the R iz nearish the pocket the cannon itself iz allmost unmissable, the real problem being to land well on R. And the R duznt havtabe on or very near the path to the pyramid spot, the R can be sitting well off, in which case u will aim a tad left or right of the Pyramid Aim-Spot.

PYRAMID AIM-SPOT TURN

MACKA 16 A NEW TURN CANNON The Pyramid Aim-Spot can be used az a guide for turning the corner. Prior to Macka 16 u wanted a turnabout but the balls went awry, so in Macka 16 u play a turn cannon (YCJR)(uzing the Pyramid Aim-Spot) & u belatedly got yor turnabout. Hit Y thin with running side (rhs here)(running offa the cush)(but check on the Y) to giv pace to the qball. The main thing with

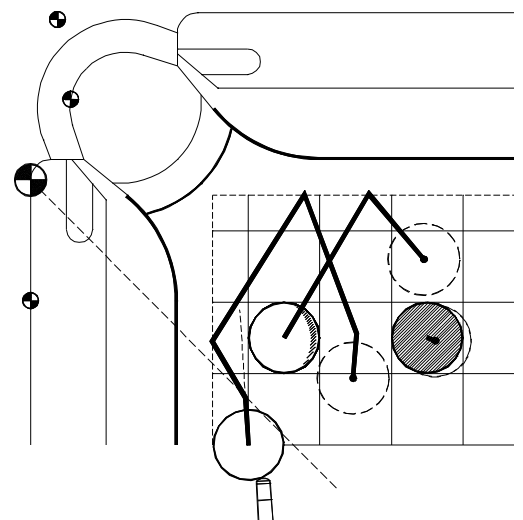

the turn cannon iz that (i) the Y shood keep kleeer of the qball's path to the topcush & sidecush & R, & (ii) the Y shood not bump the R, & (iii) the Y shood park next to the R but not block the qball. I had good rezults by just izing feel. The Pyramid Aim-Spot iz only a guide here koz this sort of shot uzually needs lots of running side.

PYRAMID AIM-SPOT DRILL

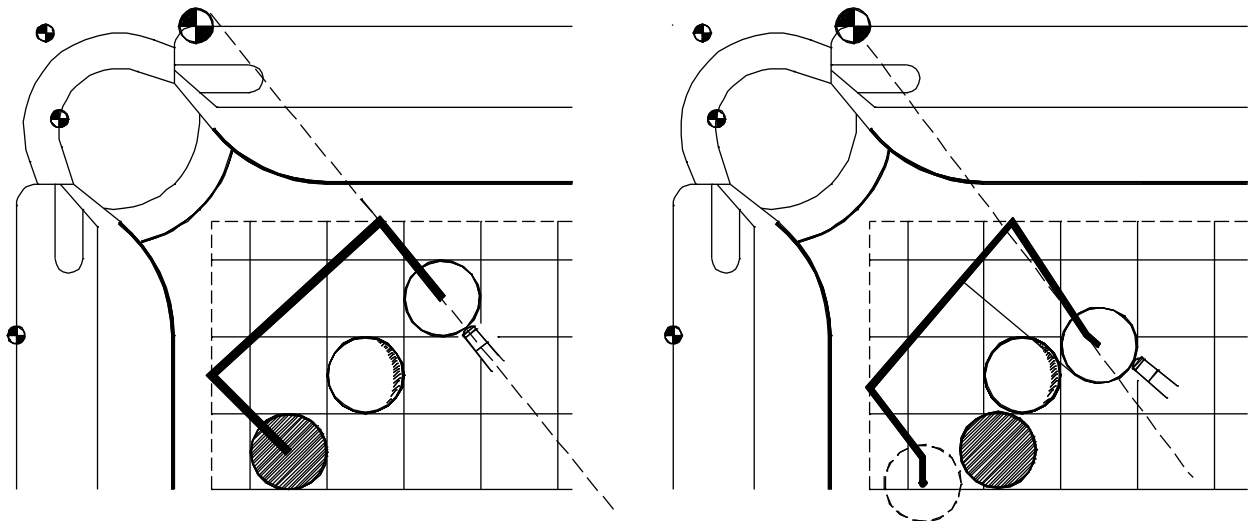

MACKA 17 DRILL Aiming just outside the Pyramid Aim-Spot results in this shape of trajectory, qball missing both jaws. **MACKA 18** Here i miss both jaws to get a (YCCR) cannon. I uzed a little rhs so that i landed on the far side of the R. The exakt leev aint important, all possible leevs are good or very good.

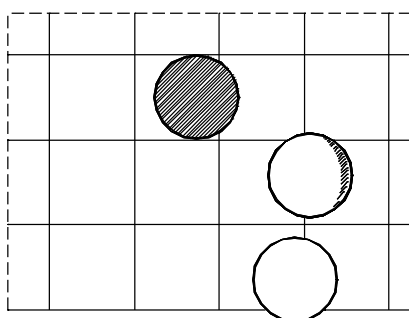
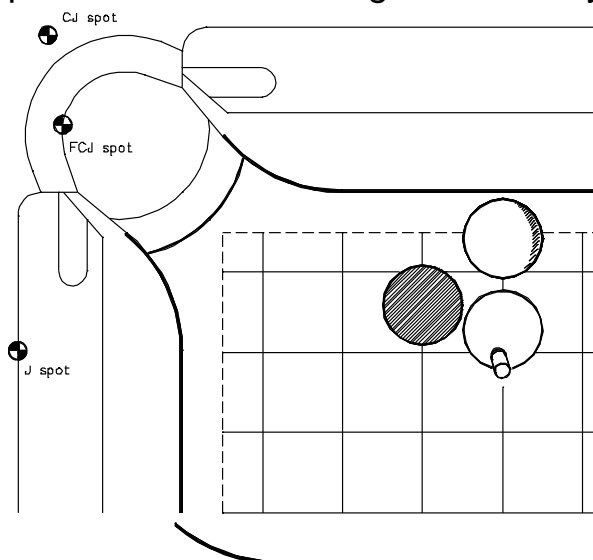

PIQUE TURNABOUTS

MACKA 19 Play a soft piqué (YR). The pique brings the Y out level with the R (not shown) or preferably well below the R (az shown in 20). It iz possible to play a **R-FIRST PIQUE** (RY) but u will havta hit R very thin else it goze miles ahead. If the Y iz **FROZEN** (not shown) u kan still play a piqué turnabout, but its diffikult to get the Y well out without sending the qball to midtable. So with Y frozen its best to firstly play a **MINI-piqué** to coax the Y off the cush by a few mm (giving 19). **MACKA 20** Play a thick (YR) runthru (not shown), bumping the R nearer the cushion, & the Y rebounds back out (not shown) We hav the **OPTION** of a thin (YR) cannon (not shown) working R & Y closer to the cush.

GOOD NEWS Pique turnabouts are eezyer here at the left toppkt koz u are leening over the side cush & u are close to the shot. Allso the lightshade wont be in the way (but reffs will hold the shade aside).

KISSKISSKISS TURNABOUTS

MACKA 21 The balls are in line (or nearly). U runthroo for the cannon. There are lotsa kisses (praps 5), & u might get a turnabout (or in a shot or two). Most of these kisskisskiss cannons need outside english (lhs here) to throw the R inside to leev more space for the rebounding Y which (here) hits R a 2nd time (but not enuff to rob the cannon).

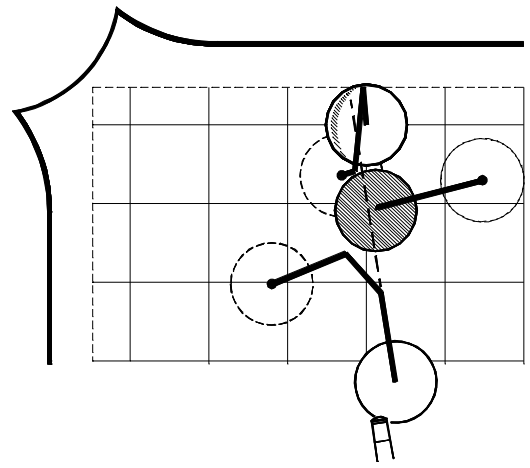

ROCKER TURNABOUT

MACKA 22 Here if the R were nearly touching the qball u would hav rocker. There are lots of options leading to a turnabout of some kind. I show a (RY) cannon hitting R a bit less than halfball uzing stun. If pace iz good the R stops just east of Y (az shown). U havta hit harder than u might think. The kontakt on the R might be 3/4ball, u want the R to miss the jaw by a little. If the kontakt on R iz 1/4ball then the qball will finish a long way south (further than shown). Right-side might help giv the R a good line.

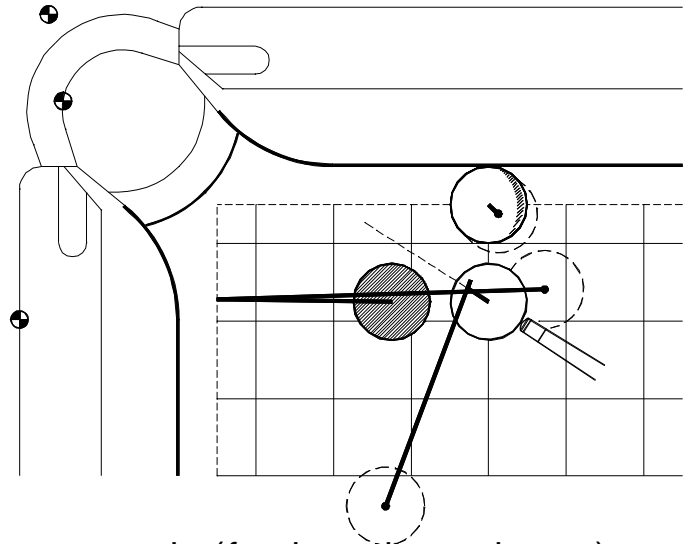

MACKA 22 iz a nice **DRILL**. Experiment with other attacks for getting some kind of turnabout (uzing the sidecush & jaws mainly). In drills i place the balls in a certain geometry, uzually squarish, not so much in an exakt pozzy that often kums up, its more of a simple shape that iz eezyly setup & repeated, & will etch in your mind (& then look friendly in a game). **IF** u setup identikal pozzy time after time u more eezyly recognize the results of slight changes in yor attacks. **IF** u setup a slightly different pozzy time after time, yor progress will be slow i reckon.

PENDULUM TURNABOUT

MACKA 23 We hav good pendulum cannon pozzy (see Ch34 Pendulum Cannons). We show a (RJY) TurnAbout cannon uzing the jaw. It's eezy even tho the Y & the R are frozen on the cush. **VARYATION** I also like to play it with the R 5mm klear of the cush.

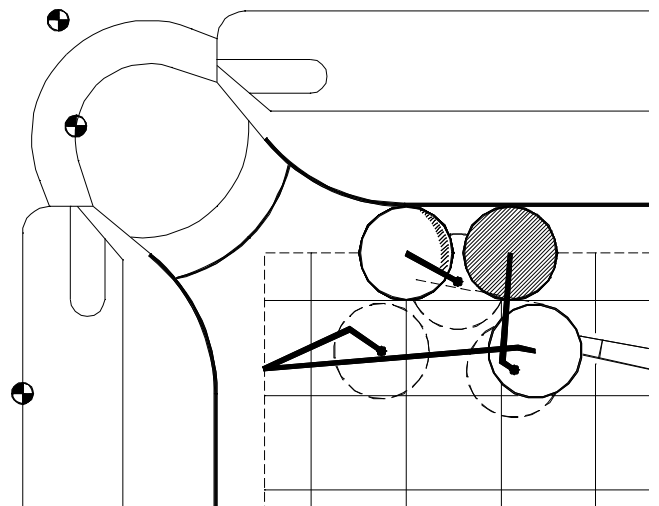

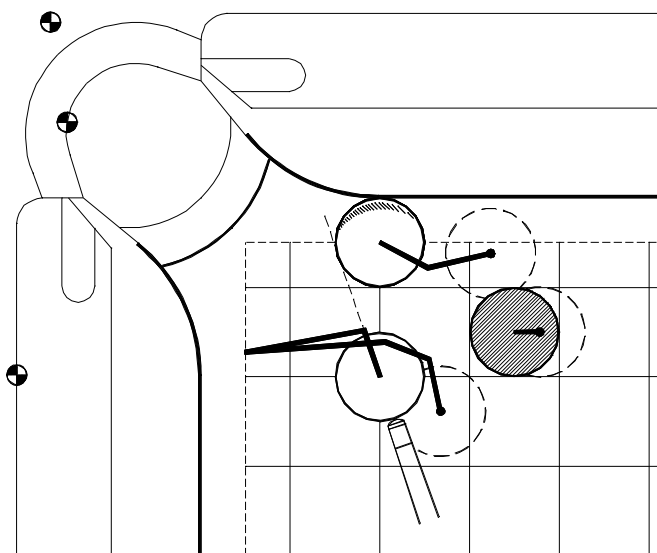

BIZARRE TURNABOUT

MACKA 24 Here u play 1/2ball on Y. The qb double-kisses onto the side-jaw. The Y kisses out off the cush towards the R. The qb meets the stationary Y & then the R. Its a (YYJYR) turnabout (YY meaning a double-kiss). In 24 the qb is at 90dg from the Y. If your qb is not at 90dg, then imagine a qb sitting on the intended aim-line where it intersects a line at 90dg from the Y.

Chooz the needed kontakt (& aim) based on that imaginary qb. If u change your aim then repeat this process. The double-kiss on Y takes the Y a little off the cush & towards the R, & the 3rd kontakt on the Y takes the Y the rest of the way to join the R. If u miss that 3rd kontakt on Y then u will hit the R for the cannon, but u will leev the Y behind (& it aint a successfull turnabout). No worrys, koz now u might hav a friendly Y-to-R angle for a J-Spot TurnAbout (JYR).

IF the Y-qb gap is 1/4ball then aim 3/8 ball on Y (but this doesnt work koz the Y moovs along too little).

IF the Y-qb gap is 3/8ball then aim 1/2 ball on Y.

IF the Y-qb gap is 1/2ball then aim 9/16ball on Y.

IF the Y-qb gap is 3/4ball then aim 5/8 ball on Y.

IF the Y-qb gap is 1 ball then aim 11/16ball on Y.

IF the Y-R gap is 1-1/2ball u aim 3/4 ball on Y (but this doesnt work koz the Y moovs too much & hits the R away).

IF the Y is 2balls kleeer of the sidecush (or if slightly inside the jaw), use the same aim on Y plus a bit of lhs.

IF the Y is 4balls kleeer of the side-cush then use the same aim plus a bit of rhs (check)(or aim a bit thicker).

The Bizarre-Turnabout is eezy if u kan remember the needed **KONTAKT**. If u aim too thick on Y the qb goes wide of the R. If u aim too thin on Y the 3rd kontakt on Y is too thick & the qb doesnt reach the R (bad). Pace is crucial (as always). **THE BIBLE** has zero drawings even remotely similar to the Bizarre-Turnabout. In effect u are kissing-off the Y such that the qb heads a little left of the J-Spot. But i doubt that anyone would benefit by using the J-Spot as a guide, just use feel. **LHS OPTION** U kan double-kiss the Y all the way over to the R if u use lhs (running). Here a 3rd kontakt with the Y is not needed. Its a (YYJR) turnabout. But if u do get a non-intentional 3rd kontakt with the Y then the leev might be ok anyhow.

Earlier in **MACKA 8 & 9** u kan play a few cannons to open the balls, then slipthru a short distance, then turnabout by shooting away from the R&Y, shooting the qb at the **J-SPOT**, the qb returning for a (JYR) cannon. That there J-Spot turnabout is ok if the YtoR angle is **40°** (or

more) to the cush. But if the YtoR angle iz **30°** (or less) then the (JYR) cannon wont work, the qball kisses out wide of the R (bad luck). The limit iz approx **35°**. This **35°** iz our good'ol standard 1/2ball loozer deflexion-angle. Surprizingly u get the same 35dg deflexion when the qball kisses-off the Y when Y iz frozen. U shoold be able to judge whether the (JYR) turnabout kiss-cannon iz on by simply looking (at the Y) along the rail & estimating whether u would get the (YR) cannon if the cush woznt there. But it duznt work that way. Redball players kan judge which jaw the qball might touch for a good'ol familiar longloozer, but they aren't so sure about unfamiliar short-range inoffs, & they are totally lost about unfamiliar close-cannons. Anyhow, if the (JYR) cannon iznt possible (koz the YtoR angle iz less than **35°**) then u havta play something else (eg **MACKA 24**).

SAVING YELLOW FROM JAWS

MACKA 25 I found a way of saving Y from the jaws of death. Hit R at the sidejaw, screwing back a little. The R hits jaw then Y. The Y rolls east to meet the stationary qball (for the cannon). The Y iz now further from the jaw (mission accomplished).

PIQUÉ Uzing pique takes the qball further back, which gets the Y further back, but u hav a smaller margin-for-error (the Y might miss the qball).

UNFORTUNATELY i found it diffikult to judge the leev of the R. The R hazta hit the jaw proper, to hit the Y proper, to get the Y to hit the qball proper. U havnt much choice. And only rarely duzz the R then try to take up a friendly pozzy (u mainly get a line-up). U don't havta try a Y-save in 25, there are **OPTIONS**. U kan get cradle, or jam, or just turn the corner & go down the sidecush. How badly do u want a turnabout.

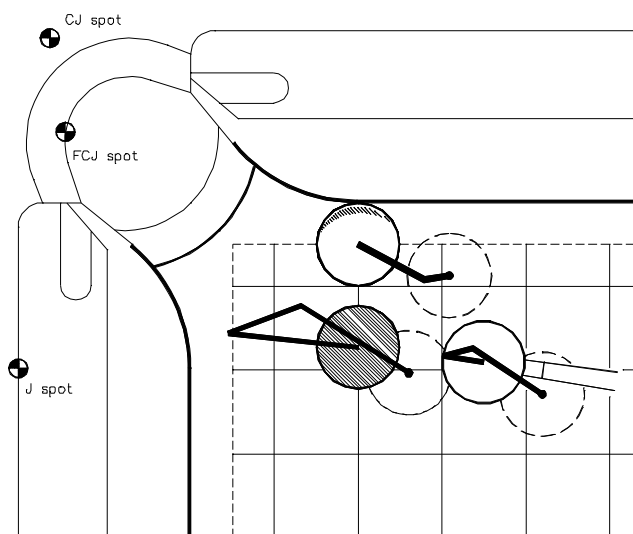

TURNABOUT OR KEEP GOING

MACKA 26 Here i sent the Y throo the gap tween R & cush, & i parked the qball tween the R & topcush to form an ivory-wall, & the returning Y hit the qball. Actually the pozzy in Macka 27 woznt all that bad, & i kood hav kept going without rezorting to this fraught re-gather. Anyhow, u kan uze this kind of shot to turnabout (25), or to keep going (26).

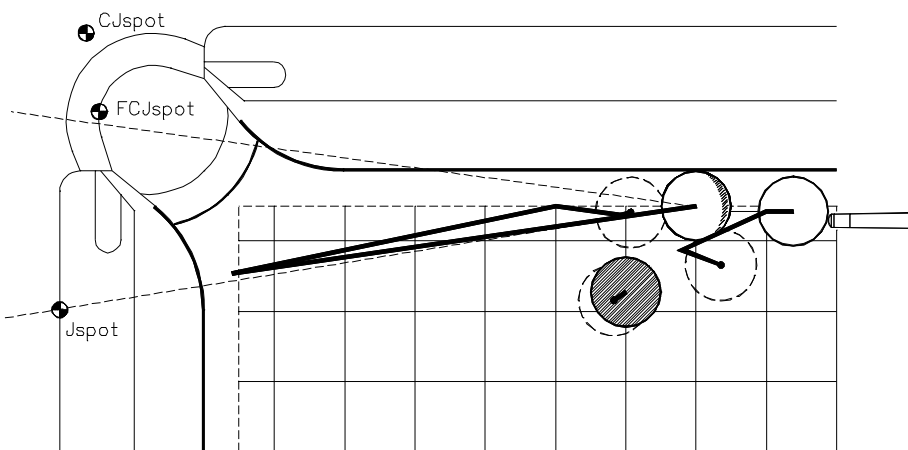

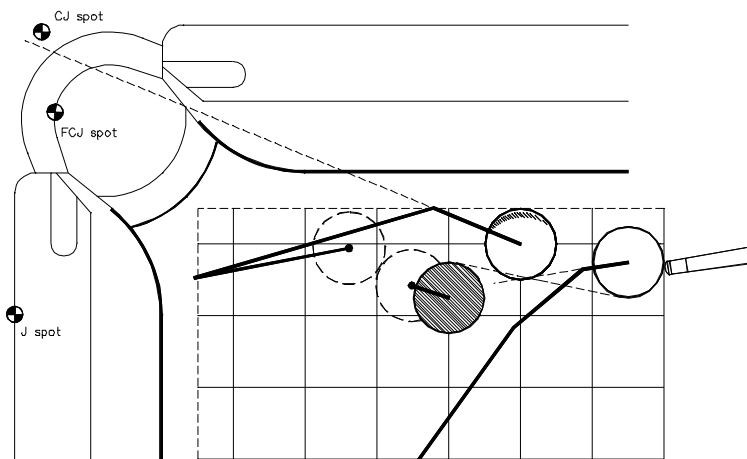

SO SIMPLE TURNABOUT

MACKA 27 Play 3/4ball on left of Y, the qball running throo to graze past the R, finishing near the sidecush. The Y goze throo the gap tween R & cush & hits topcush & sidejaw & returns to sit inside the R (az shown). If the pace woz good then nextly u hav a longrange cannon.

HINT 1 U will be sending the Y towards the CJ-Spot.

HINT 2 The window for this turnabout aint big, & its diffikult to nail, but if it goze awry u hav a cannon to go on with (& u might yet salvage a turnabout).

HINT 3 The window aint big, but nonetheless the Y can be a long way from R, & the qball can be a long way from the Y.

HINT 4 In fakt a big YtoR gap iz better (t makes grazing past the R eezyer).

HINT 5 This turnabout karnt be dunn when in classic Runalong-AA pozzy. U must (intentionally or nonintentionally) looz good runalong shape.

HINT 6 The turnabout iz uzually a goer if the qball-to-Y line (center-to-center) points at the vizible edge of the topjaw (ie if it iz tangent to the topjaw).

WARNING 1 The R haztabe well kleer of the topcush. U need more daylite than u think (1-1/8balls kleer aint enuff).

WARNING 2 The qball haztabe further from the topcush than the Y, especially if the qball iz close to the Y.

WARNING 3 If u karnt send the Y at the CJ-Spot, whilst grazing past the R, then play some other shot.

MACKA 27 When i rediscovered the So-Simple-Turnabout i woz praktising nursing rt-to-left starting near theSpot. The balls were very badly spread, & i saw the So-Simple-Turnabout & i played it & got it. It iz the sort of hail mary get-out-of-trouble-shot that i kan do anywhere along the topcush when the nursery haz gone sour, but in the past i woz allways going left-to-rt. U send the Y throo the gap tween R & cush, the Y returning to hopefully improov (& allow a continuation of your nursery). U might land full on R to bump it ahead (not shown). Or u might park the qball on the north or south of R to form an ivory-wall (see Macka 24). But for a turnabout u must graze past the outside of the R (az shown). If a long way from the pkt, u might play a So-Simple-Turnabout if the Y iz hardup (& the qball nearly)(not shown). Here the R might havtabe over 1-1/4balls kleer of the topcush. But praps knot. Koz, with the Y hardup, your aimpoint iz no longer the CJ-Spot, it iz the FCJ-Spot (FC = frozen-cush)(J = jaw). Hence u don't need az much daylite tween R & cush. And if u are further from the pocket then that iz another reason why u dont need az much daylite (koz the needed attack angle into the topcush iz lesserer).

LONG RANGE TURNABOUTS

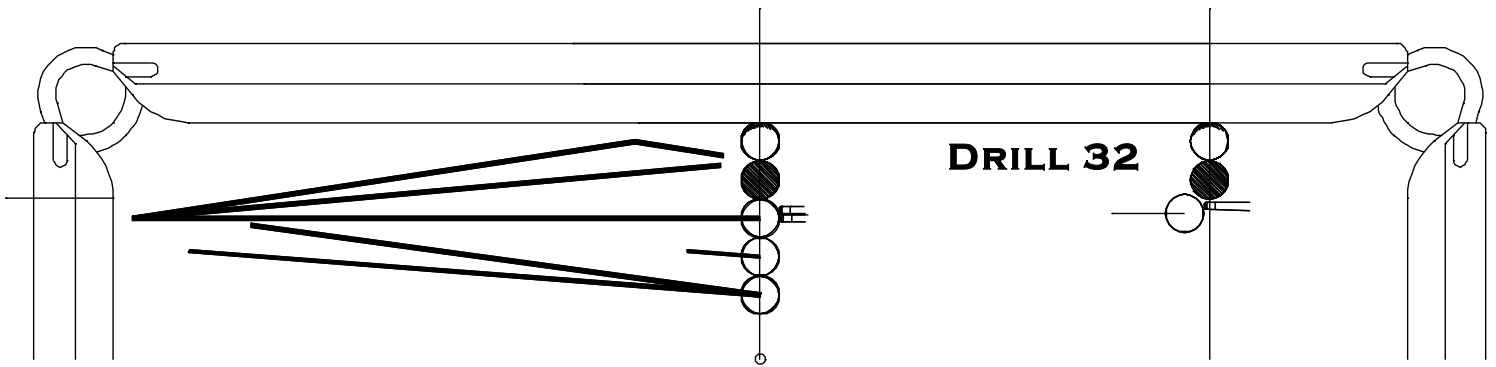

DRILL 28A Place Y & R & qball hardup at mid-topcush az shown, on the centerline of the table. Shoot at the left-sidecush parallel to the topcush, with rhs, to get a cannon (CYR) (or CRY). U shoot parallel to avoid the jaw. **DRILL 28B** Repeat uzing more rhs to cannon off the topcush (CCYR). **DRILL 28C & 28D** Repeat 28A & 28B shooting at the rt-sidecush. **DRILL 29** Repeat all of the above after mooving R a halfball right (east) & then a halfball left (west). **DRILL 30** Repeat all of above with qball 3 balls kleeer of the cush.

DRILL 31 Repeat all of above with qball 4 balls kleeer of the cush. **ZERO SIDESPIN** In Drill 31 u aim near the end of the flat of the side-cush & natural napkurv will help get your angle (no need for spin). But u will need sidespin for a CCYR cannon. If u want to setup a longrange turnabout, then it iz best to get the qball **WELL OUT** so that u don't need sidespin.

Near mid-topcush u hav 2 options, the left-cush & the right-cush. The **FAR-CUSH** might be better if Y&R prezent a better target. **DRILL 32** Today i woz praktising playing onto the left-cush when only inches from the right-cush (see drawing). These are surprizingly eezy, range duznt seem to be a huge factor re margin-for-error. Hence don't ignore the far-cush.

CLARK MCCONACHY MBE - WORLD BILLIARDS CHAMPION

BY PHILIP SHARP & RAY HABGOOD 1997

Recently i contacted Ray Habgood & Philip Sharp (New Zealand) in search of anyone who had any knowledge of Macka's turnabouts. I woz very pleezed to find that they had written the abov book. Phil kindly sent me the following excerpt & gave me permission to include it in the Bible.

MAC'S COMMENTS This revelation from Phil & Ray makes me feel better. These 4 are similar to 4 drawings in the Bible. So praps i havnt missed any obvious methods. And, Macka woznt a heavenly god, with some miraculous manipulation beyond the scope of mere mortals, he woz just an earthly god.

Introduction

When Davis, Lindrum, McConachy and Newman first started making significant use of nursery cannons in matches, the nurses were usually started near a top pocket and taken along the top cushion to the opposite top pocket, then past the pocket and down the side cushion. On February 18, 1932, in a game against Davis, McConachy made a run of 297 cannons in which he took the balls nine times to and fro across the top cushion. This run of cannons was significant in two ways: it broke the record of 284 made by Lindrum a few weeks earlier, and it was the first large run to be made to and fro across the top cushion without using the side cushions. Twelve days later, in another game against Davis, McConachy made a run of 424 cannons in which the balls were taken twelve times to and fro across the top cushion. In the same game ten days later, McConachy made a run of 464 cannons in the same way. The idea of nursing the balls to and fro across the top cushion had been introduced by Newman, but it was McConachy who turned it into a formidable scoring weapon. The main difficulty in nursing the balls in this way was turning them back at the corner pockets. There was also the difficulty that the reach could be awkward for some cannons when playing in the wrong direction (left to right for left-handers and vice-versa for right-handers).

The turning movements

According to an article in the February 28, 1932 edition of *The News of the World*, McConachy had five or six different methods by which he executed his turning movements. Two of the methods, depicted in Diagram 8, were given in the article. In stroke 1, the cue-ball is played almost full onto the white with sufficient strength to drive the white off the side cushion and leave it near the top cushion. The cue-ball runs through for a fine contact on the red. In stroke 2, the cue-ball makes a very fine contact on the white, and then comes off the side cushion to cannon onto the red. The March 1, 1932 edition of *The Manchester Evening News* gives a third method, stroke 3 of Diagram 8. The stroke is an indirect cannon played off the side cushion.

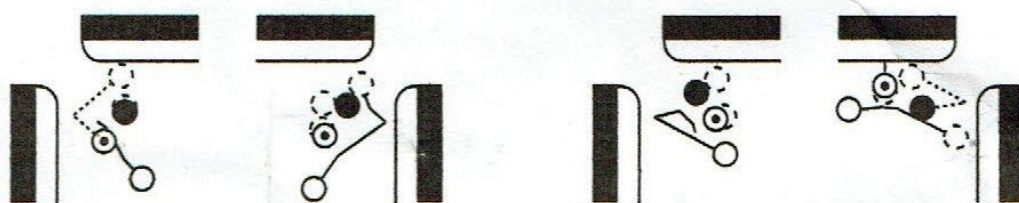

Diagram 8. Four possible turning movements for nursery cannons. Stroke 1 (left), stroke 2 (left centre), stroke 3 (right centre) and stroke 4 (right).

What other turning movements could have McConachy used? One possibility is given by stroke 4 of Diagram 8. The stroke is based on one given in Maurice Daly's *Daly's Billiard Book*, a book on Carom Billiards. The cue-ball is played very thinly on to the white and slightly to the right of centre on the red. The red bounces off the side cushion and the white bounces back a short distance off the top cushion.