

City of Ironwood
213 S. Marquette St.
Ironwood, MI 49938



IRONWOOD

MICHIGAN | *Find Your North*

Phone: (906) 932-5050
Fax: (906) 932-5745
www.cityofironwood.org

AGENDA
REGULAR IRONWOOD CITY COMMISSION MEETING
MONDAY, APRIL 26, 2021
Regular Meeting - 5:30 P.M.

TO BE HELD VIA ZOOM

(Please visit the City website at www.cityofironwood.org or the notice posted at the Memorial Building for Zoom Webinar login instructions.)

- A. Regular Meeting Called to Order.
Pledge of Allegiance.
- B. Recording of the Roll.
- C. Approval of the Consent Agenda.*

All items with an asterisk () are considered to be routine by the City Commission and will be enacted by one motion. There will be no separate discussion of those items unless a Commission member or citizen so requests, in which event the item will be removed from the General Order of Business and considered in its normal sequence on the agenda.*

- *1) Approval of Minutes – Regular City Commission Meeting of April 12, 2021.
- *2) Review and Place on File:
 - a. Economic Development Corporation (EDC) Meeting Minutes of February 5, 2020, June 3, 2020, July 1, 2020, August 5, 2020, October 7, 2020, and January 13, 2021.
 - b. Pat O'Donnell Civic Center Meeting Minutes of April 5, 2021.
 - c. Ironwood Housing Commission Meeting Minutes of April 13, 2021.

- D. Approval of the Agenda
- E. Review and Place on File:
 - 1. Revenue & Expenditure Report.
 - 2. Cash and Investment Summary Report.
- F. Approval of Monthly Check Register Report.
- G. Citizens wishing to address the Commission on Items on the Agenda. (Three Minute Limit).



This Institution is an Equal Opportunity Provider, Employer and Housing Employer/Lender



- H. Citizens wishing to address the Commission on Items not on the Agenda (Three Minute Limit)
- I. PRESENTATION: Jason Alonen, Code Enforcement Officer (RE: 2021 Blight Process Update)
- J. UPDATE: COVID-19 Response.

OLD BUSINESS

- K. Discuss and Consider scheduling a show cause hearing for a zoning violation by Tula Toilets & Septic, LLC, 500 W. Cloverland Dr., Ironwood, MI (52-16-483-080) for Monday, May 10, 2021 at 5:25 p.m.
- L. Discuss and consider approving quotation from Fabick Cat for repairs to the 2005-430D Backhoe Loader #85 in the amount of \$12,365.61.
- M. Discuss and consider resuming charges for City water/sewer and refuse late payment fees, water turn on/off fees.
- N. Discuss and consider approving engineering service agreement with Coleman Engineering for the USDA Rural Development Funding Application for the Phase V Water and Sewer Project.
- O. Discuss and consider awarding the bid for the installation of children's playground equipment north of US 2 (Lowell St./Midland).

NEW BUSINESS

- P. Discuss and Consider approving the sale of Ironwood Public Safety Department duty weapon (Officer Michael Rimkus) to the Ironwood Professional Police Association for \$1.00 to be presented to Officer Michael Rimkus upon his upcoming retirement.
- Q. Discuss "No Parking" traffic control order and street striping status on Norrie Street between Lowell Street and Hemlock Street.
- R. Discuss and City of Ironwood of dog and cat's ordinance.
- S. Discuss and Consider authorizing bids for an asphalt hot box.
- T. Discuss and Consider approving the purchase of a downtown ornamental streetlight from Graybar in the amount of \$5,247.94, plus shipping.
- U. Discuss and Consider authorizing payment for emergency repairs to the Highlift Booster Pump #1 to Kleiman Pump & Well Drilling for \$17,047.24.
- V. Manager's Report.
- W. Other Matters.
- X. Adjournment.

Proceedings of the Ironwood City Commission Meeting

A Regular Meeting of the Ironwood City Commission was held via Zoom on Monday, April 12, 2021 at 5:30 P.M., along with a regular Public Hearing at 5:25 P.M..

1. Mayor Burchell called the public hearing to order at 5:25 P.M.

2. Recording of the Roll

The following members who were in attendance indicated the physical location from which they were remotely participating in the meeting were as follows: Commissioner Cayer (City of Ironwood, Gogebic County, State of Michigan), Commissioner Corcoran (City of Ironwood, Gogebic County, State of Michigan), Commissioner Mildren (City of Ironwood, Gogebic County, State of Michigan), Commissioner Semo (City of Ironwood, Gogebic County, State of Michigan), and Mayor Burchell (City of Ironwood, Gogebic County, State of Michigan).

PRESENT: Commissioner Cayer, Corcoran, Mildren, Semo, and Mayor Burchell.

ABSENT: None.

3. Mayor Burchell opened the Public Hearing at 5:26 P.M.

4. Public Hearing: To hear comment on a blight violation of Corey and Cynthia Sandy at 39 Newport Heights S. (Parcel #52-24-178-240).

Blight Enforcement Officer Jason Alonen addressed the City Commission regarding the blight violation at 39 Newport Heights S. Mr. Alonen showed several pictures of the property and stated the homeowners had cleaned up the front yard. The backyard still had junk in it and there was an unlicensed camper in the side yard.

Kevin Benner, of 15 Newport Heights thanked the City Staff for how quickly the front yard got cleaned up.

Dan Kauppi, of 12 Newport Heights stated he has lived in the neighborhood for 26 years and has complained about this property over the years.

Aleen Fuchs, of 624 E. Bonnie also addressed the City Commission informing them that her dog was killed by the two (2) husky's that live at this property. She also stated there was approximately 10 dogs that were taken and then returned to the homeowner. Ms. Fuchs wanted an update on what transpired between animal control and the homeowner. Further discussion of this matter took place.

Joe Braspenick, of 33 Newport Heights stated for two (2) years he has been complaining about the dog waste and smell that is coming from this property. No other comments were received.

5. Mayor Burchell closed the Public Hearing at 5:45 P.M.

A. Mayor Burchell called the regular meeting order at 5:45 P.M.

B. Recording of the Roll.

The following members who were in attendance indicated the physical location from which they were remotely participating in the meeting were as follows: Commissioner Cayer (City of Ironwood, Gogebic County, State of Michigan), Commissioner Corcoran (City of Ironwood, Gogebic County, State of Michigan), Commissioner Mildren (City of Ironwood, Gogebic County, State of Michigan), Commissioner Semo (City of Ironwood, Gogebic County, State of Michigan), and Mayor Burchell (City of Ironwood, Gogebic County, State of Michigan).

PRESENT: Commissioner Cayer, Corcoran, Mildren, Semo, and Mayor Burchell.

ABSENT: None.

C. Approval of the Consent Agenda.*

*1) Approval of Minutes – Regular City Commission Meeting Minutes of 3/22/21.

*2) Review and Place on File:

a. Downtown Ironwood Development Authority (DIDA) Meeting Minutes of 9/24/20, 10/22/20, 11/19/20, 12/17/20, and 1/28/21.

Motion was made by Corcoran, seconded by Cayer to approve the Consent Agenda as presented. Unanimously passed by roll call vote.

D. Approval of the Agenda

Motion was made by Cayer, seconded by Corcoran to approve the Agenda as presented. Unanimously passed by roll call vote.

E. Citizens wishing to address the Commission on Items on the Agenda. (Three Minute Limit).

There none.

F. Citizens wishing to address the Commission on Items not on the Agenda (Three Minute Limit)

Kaitlyn Holcome, of 221 S. Curry Street questioned the City Commission regarding the Cemetery. It was then discovered she was referring to the touchless faucets that were installed last year.

G. UPDATE: COVID-19 Response.

Public Safety Director Andrew DiGiorgio mentioned that the Western UP Health Department would be holding vaccination clinics every Tuesday for the next seven (7) weeks. If someone needs a vaccination, he urged them to call the Western UP Health Department at 667-0200 to schedule an appointment.

Community Development Director Tom Bergman noted he is still waiting for the guidelines for the new programs. He further added notices were sent out to all the local restaurant businesses.

Finance Director Paul Linn mentioned he is also waiting for the US Treasury to give guidance on what funds can be spent on.

OLD BUSINESS

H. Discuss and Consider adopting Resolution #021-011 Ordering Removal and Abatement of the Hazard and Nuisance of Corey and Cynthia Sandy residence located at 39 Newport Heights S. (Parcel #52-24-178-240).

***Motion** was made by Cayer, seconded by Mildren to adopt Resolution #021-011 Ordering Removal and Abatement of the Hazard and Nuisance of Corey and Cynthia Sandy residence located at 39 Newport Heights S. (Parcel #52-24-178-240) if not cleaned up by May 3rd. Unanimously passed by roll call vote.*

I. Discuss and Consider awarding bid for the Ironwood Memorial Building and Mausoleum Tuck Pointing Project to RAM Construction Services in the amount of \$19,000.00.

***Motion** was made by Corcoran, seconded by Mildren to award the bid for the Ironwood Memorial Building and Mausoleum Tuck Pointing Project to RAM Construction Services in the amount of \$19,000.00. Unanimously passed by roll call vote.*

J. Discuss and Consider awarding bid for Mine Shaft Safety Fencing and Jessievile Elevated Storage Tank Fencing to JCS, Inc. in the amount of \$28,866.00.

***Motion** was made Corcoran, seconded by Mildren to award the bid for Mine Shaft Safety Fencing and Jessievile Elevated Storage Tank Fencing to JCS, Inc. in the amount of \$28,866.00. Unanimously passed by roll call vote.*

K. Discuss and Consider awarding bid for Patching and Painting of Memorial Building Gymnasium to Vukovich Construction in the amount of \$37,400.00.

***Motion** was made by Mildren, seconded by Cayer to award the bid for Patching and Painting of Memorial Building Gymnasium and balcony to Vukovich Construction in the amount of \$37,400.00. Unanimously passed by roll call vote.*

L. Discuss and Consider awarding bid for Well Rehabilitation (Well #203) to Binz Brothers in the amount of \$37,000.

***Motion** was made by Corcoran, seconded by Cayer to award the bid for Well Rehabilitation (Well #203) to Binz Brothers in the amount of \$37,000.00. Unanimously passed by roll call vote.*

- M. Discuss and Consider awarding bid for Miners' Memorial Heritage Park Mountain Bike Trail Construction and Wayfinding Signs (Phase II) to Flowtrack Mountain Bike Trails, LLC in the amount of \$264,364.40, contingent upon concurrence and approval of the Michigan DNR Trust Fund.

Community Development Director Tom Bergman explained to the City Commission the City has already received notification of approval from the Michigan DNR Trust Fund for Phase I and Phase II of the Miners' Memorial Heritage Park Mountain Bike Trail Construction including Wayfinding Signs and Parking Lot. He also mentioned the local match of 30% would be met with \$66,000.00 coming from the Ironwood Tourism Council, \$40,000.00 from SISU Dirt Crew, and \$14,000.00 of in-kind work provided by the City of Ironwood for a total of \$120,000.00.

***Motion** was made by Corcoran, seconded by Mildren to award the bid for the Miners' Memorial Heritage Park Mountain Bike Trail Construction and Wayfinding Signs (Phase II) to Flowtrack Mountain Bike Trails, LLC in the amount of \$264,364.40 and remove the contingency. Unanimously passed by roll call vote.*

- N. Discuss and consider awarding bid to Jakes Excavation in the amount of \$1,668,324.34 for 2021 Water and Sewer Project.

***Motion** was made by Mildren, seconded by Corcoran to award the bid to Jakes Excavation in the amount of \$1,668,324.34 for 2021 Water and Sewer Project. Unanimously passed by roll call vote.*

- O. Discuss and consider approving Engineering Service Agreement with HDR of St. Louis Park, Minnesota for the design and project management services for the City of Ironwood Water Treatment Plant Project.

***Motion** was made by Corcoran, seconded by Cayer to approve the Engineering Service Agreement with HDR of St. Louis Park, Minnesota for the design and project management services for the City of Ironwood Water Treatment Plant Project and authorize the mayor to sign same. Unanimously passed by roll call vote.*

NEW BUSINESS

- P. Discuss and consider approving request from Friends of the Miners' Memorial Heritage Park (FMMHP) to construct a storage garage along the compost site road within the Miners' Memorial Heritage Park.

***Motion** was made by Mildren, seconded by Cayer to approve the request from Friends of the Miners' Memorial Heritage Park (FMMHP) to construct a storage garage along the compost site road within the Miners' Memorial Heritage Park, or two (2) other designated sites. Unanimously passed by roll call vote.*

- Q. Discuss and consider approving quote for a truck box for vehicle #23 (2007-GMC-1 ton Pick Up) from Monroe Truck Equipment, Inc. in the amount of \$5,544.00.

***Motion** was made by Semo, seconded by Cayer to approve the quote for a truck box for vehicle #23 (2007-GMC-1 ton Pick Up) from Monroe Truck Equipment, Inc. in the amount of \$5,544.00. Unanimously passed by roll call vote.*

R. Other Matters.

Commissioner Corcoran noted she was riding around Ironwood and noticed there is additional blight on Copper, Oak, and Ironwood Streets. She also suggested extra garbage cans be placed around town and to be proactive and give the property owners a heads up on cleaning up.

Commissioner Cayer thanked Steve Frank for picking up garbage around town.

Commissioner Mildren thanked the residents who keep their property looking nice.

Mayor Burchell felt it would be wonderful if we could step in before the blighted property becomes a problem.

S. Adjournment.

***Motion** was made by Cayer, seconded by Semo to adjourn the meeting at 6:50 P.M. Unanimously passed by roll call vote.*

Annette Da Lio-Burchell, Mayor

Karen M. Gullan, City Clerk



IRONWOOD
MICHIGAN | *Find Your North*

**Proceedings of the Economic Development Corporation Meeting
Wednesday, February 5, 2019~~20~~**

2020 A Regular Meeting of the Economic Development Corporation (EDC) was held on Wednesday, February 5, 2019~~20~~ at 10:00 A.M. in the Women’s Club Room, Second Floor of the Municipal Memorial Building in the City of Ironwood, Michigan.

1. Chair Wyssling called the meeting to order at 10:00 a.m.
2. Election of Chair and Vice Chair.
 - A. Ramme nominated Wyssling as Chair.
Ruppe made motion to elect Wyssling as Chair. Second by Korpela. All in favor.
 - Lemke nominated Ramme as Vice-Chair.
Lemke made motion to elect Ramme as Vice-Chair. Second by Korpela. All in favor.
3. Recording of the Roll

MEMBER	Present		EXCUSED	NOT EXCUSED
	YES	NO		
Thorsen, Gina		X	X	
Lemke, Joseph	X			
Korpela, Nancy	X			
Sclafani, Velda		X	X	
Ramme, Dave	X			
Ruppe, Mark	X			
Schonberg, Bob		X	X	
Wyssling, John	X			
Gary Burnett		X	X	
Quorum	5	4	Quorum	

Also Present: Community Development Director Tom Bergman and Community Development Strategist Tim Erickson.

4. Approval of the November 6, 2019 Meeting Minutes:

Motion by Korpela to accept the November 6, 2019 meeting minutes. **Second** by Lemke.
Motion Carried 5 to 0.

5. Approval of the Agenda

Motion by Korpela to accept the Agenda. **Second** by Ramme. **Motion Carried 5 to 0.**

6. Citizens wishing to address the Corporation regarding Items on the Agenda (Three-minute limit):
None.

7. Citizens wishing to address the Corporation regarding items not on the Agenda (Three-minute limit): None.

8. Goal Setting for 2020

- A. Director Bergman presented some economic development-based projects to focus on. He discussed retail target market analysis with accommodation focus, industrial analysis. The Corporation talked about doing a review the retail target market analysis accommodation, housing (higher end), and industrial needs to support existing industry; TIF District; Mentorship/Business Retention; Marketing for remote workers (Tech Maker Space); Redevelopment Ready Communities.

Motion by Korpela to accept the goals. **Second** by Ramme. **Motion Carried 5 to 0.**

9. Approve Meeting Schedule for 2020 (Jan. 8, Feb. 5, Mar. 4, Apr. 1, May 6, June 3, July 1, Aug. 5, Sept. 2, Oct. 7, Nov. 4, Dec. 3)

Motion by Ruppe to approve the meeting schedule. **Second** by Korpela. **Motion Carried 5 to 0.**

10. Items for Discussion and Consideration:

A. Redevelopment Ready Communities Priority Sites.

I. Update on Zoning Ordinance (Marihuana Ordinance).

1. Director Bergman gave an overview of how the marihuana ordinance process has been going. He encouraged the EDC members to come to the next Planning Commission meeting as they will be discussing the ordinance.

B. Comprehensive Plan Implementation Status of Priority Action Items:

I. Strategy 6.4 Workforce Development.

1. EDA Grant for Emergency Economic Development Coordinator.

- a. Director Bergman said that the county municipalities are working on getting a grant to fund an economic development coordinator

to help start a county wide economic development organization housed at the College.

2. Retention Program Visits

- a. Vicki Schwab with the MEDC made a visit recently.

II. Strategy 6.2(b) Implement Endowment Fund Program for Economic Development.

1. Update on Project Gogebic strategic planning session.

- a. The document has been complete and will be presented to the public soon.

III. Strategy 6.3(g & h) Develop/Continue a Business Incubator and Entrepreneurial Support Spaces.

1. Korpela discussed collaborating with Invent@NMU and Invest U.P.

11. Other Business: Ruppe asked if the EDC has any outstanding revolving loan funds. Bergman said that Director Linn can give an update and that the debts are working toward being forgiven.

12. Next Meeting: March 4, 2020 at 10:00 a.m.

13. Adjournment. **Motion** by Ruppe to adjourn at 10:54 a.m. **Second** by Lemke. **Motion Carried 5 to 0.**

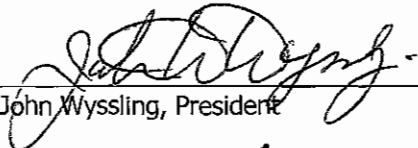

John Wyssling, President

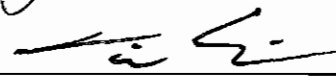

Tim Erickson, Community Development Assistant



IRONWOOD

MICHIGAN | *Find Your North*

Proceedings of the Economic Development Corporation Meeting Wednesday, June 3, 2020

A Regular Meeting of the Economic Development Corporation (EDC) was held on Wednesday, June 3, 2020 at 10:00 A.M. via ZOOM

1. Chair Wyssling called the meeting to order at 10:00 a.m.
2. Recording of the Roll

MEMBER	Present		EXCUSED	NOT EXCUSED
	YES	NO		
Thorsen, Gina	X			
Lemke, Joseph	X			
Korpela, Nancy	X			
Sclafani, Velda	X			
Ramme, Dave		X	X	
Ruppe, Mark		X	X	
Schonberg, Bob		X	X	
Wyssling, John	X			
Gary Burnett	X			
Quorum	6	3	Quorum	

Also Present: Community Development Director Tom Bergman and Community Development Strategist Tim Erickson.

3. Approval of the February 5, 2020 Meeting Minutes:
Motion by Thorsen to accept the February 5, 2020 meeting minutes. **Second** by Korpela.
Motion Carried 6 to 0.
4. Approval of the Agenda
Motion by Thorsen to accept the Agenda. **Second** by Lemke. **Motion Carried 6 to 0.**
5. Citizens wishing to address the Corporation regarding Items on the Agenda (Three-minute limit):
None.

6. Citizens wishing to address the Corporation regarding items not on the Agenda (Three-minute limit): None.

7. Audience with Paul Linn to discuss outstanding revolving loans.

A. Director Bergman gave an update on the status of the revolving loan funds. They discussed the need to have the loans forgiven and asked why the debts weren't transferred to the Northern Initiatives.

Motion by Korpela to accept the goals. **Second** by Ramme. **Motion Carried 5 to 0.**

8. Items for Discussion and Consideration:

A. COVID-19 Business Update: Director Bergman gave an update on how the memorial building will be opening. He also discussed the role that Community Development has been taking to help businesses. He also gave an update with the creation of the new Economic Development Organization for the region.

9. Other Business:

10. Next Meeting: July 1, 2020 at 10:00 a.m.

11. Adjournment. **Motion** by Lemke to adjourn at 10:38 a.m. **Second** by Thorsen. **Motion Carried 6 to 0.**



John Wyssling, President

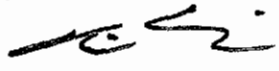

Tim Erickson, Community Development Assistant



IRONWOOD

MICHIGAN | *Find Your North*

Proceedings of the Economic Development Corporation Meeting Wednesday, July 1, 2020

A Regular Meeting of the Economic Development Corporation (EDC) was held on Wednesday, July 1, 2020 at 10:00 A.M. via ZOOM

1. Chair Wyssling called the meeting to order at 10:00 a.m.
2. Recording of the Roll

MEMBER	Present		EXCUSED	NOT EXCUSED
	YES	NO		
Thorsen, Gina		X	X	
Lemke, Joseph		X	X	
Korpela, Nancy	X			
Sclafani, Velda	X			
Ramme, Dave	X			
Ruppe, Mark		X	X	
Schonberg, Bob		X	X	
Wyssling, John	X			
Gary Burnett	X			
Quorum	5	4	Quorum	

Also Present: Community Development Director Tom Bergman and Community Development Strategist Tim Erickson.

3. Approval of the June 3, 2020 Meeting Minutes:
Motion by Ramme to accept the June 3, 2020 meeting minutes. **Second** by Korpela. **Motion Carried 5 to 0.**
4. Approval of the Agenda
Motion by Ramme to accept the Agenda. **Second** by Korpela. **Motion Carried 5 to 0.**
5. Citizens wishing to address the Corporation regarding Items on the Agenda (Three-minute limit):
None.

6. Citizens wishing to address the Corporation regarding items not on the Agenda (Three-minute limit): None.
7. Items for Discussion and Consideration.
 - A. COVID-19 Business Update: Director Bergman gave an update with the Downtown funding grant through the MEDC. The DIDA applied for it but was not successful in securing funding. He talked about a new grant through the MEDC that the city will be applying for to help businesses in the City of Ironwood. Public safety has been working with business to help them keep their customers and employees safe.
 - B. Update on TIF District for Downtown: Director Bergman said that the City Commission budgeted \$15,000 to provide funding for the development of the TIF plan. The DIDA is budgeting \$5,000 in hopes of getting an MEDC Redevelopment Ready Communities grant of \$20,000. He talked about the need to start the TIF district when the property values are at their lowest point. He discussed the need to get buy in from the other local taxing entities as a reason for the lengthy process.
 - C. Adult Use Marihuana Establishment Ordinance Update: Director Bergman stated that the process is starting again. The City Commission is looking at changes to the ordinance. July 27th is the first opportunity for a public hearing and potential adoption. He talked about the City Commission to allow 90 days to allow staff to create policy guidelines after adoption. He brought up nuisance ordinance that will help to reduce odor issues in the City of Ironwood. The Michigan Supreme Court allows municipalities to regulate the Medical Marijuana operations under zoning.
8. Other Business: None.
9. Next Meeting: August 5, 2020 at 10:00 a.m.
10. Adjournment. **Motion** by Ramme to adjourn at 10:18 a.m. **Second** by Scafani. **Motion Carried 5 to 0.**

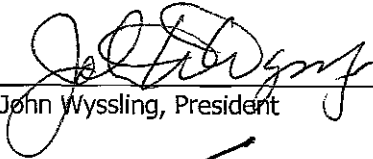

John Wyssling, President



Tim Erickson, Community Development Assistant



IRONWOOD
MICHIGAN | *Find Your North*

**Proceedings of the Economic Development Corporation Meeting
Wednesday, August 5, 2020**

A Regular Meeting of the Economic Development Corporation (EDC) was held on Wednesday, August 5, 2020 at 10:00 A.M. via ZOOM

1. Chair Wyssling called the meeting to order at 10:05 a.m.
2. Recording of the Roll

MEMBER	Present		EXCUSED	NOT EXCUSED
	YES	NO		
Thorsen, Gina	X			
Lemke, Joseph	X			
Korpela, Nancy	X			
Sclafani, Velda	X			
Ramme, Dave	X			
Ruppe, Mark		X	X	
Schonberg, Bob		X	X	
Wyssling, John	X			
Gary Burnett		X	X	
Quorum	6	3	Quorum	

Also Present: Community Development Director Tom Bergman and Community Development Strategist Tim Erickson.

3. Approval of the July 1, 2020 Meeting Minutes:
Motion by Ramme to accept the July 1, 2020 meeting minutes. **Second** by Thorsen. **Motion Carried 6 to 0.**
4. Approval of the Agenda
Motion by Thorsen to accept the Agenda. **Second** by Ramme. **Motion Carried 6 to 0.**
5. Citizens wishing to address the Corporation regarding Items on the Agenda (Three-minute limit):
None.

6. Citizens wishing to address the Corporation regarding items not on the Agenda (Three-minute limit): None.
7. Audience with Stave Lehto, Jr. Employer Specialist with Michigan Works: Director Bergman allowed Steve to address the Corporation. He introduced himself and discussed his role with Michigan Works.
8. Items for Discussion and Consideration.
 - A. COVID-19 Business Update: Director Bergman discussed the Michigan Business Restart Program. He stated that there have been about 25 applicants from the City of Ironwood so far.
 - B. Update on TIF District for Downtown: Director Bergman spoke with Jen Tucker with the MEDC. The City Commission has budgeted \$15,000 and the DIDA has budgeted \$5,000 for the TIF plan. Tucker said that the zoning ordinance needs to be completed before the TIF plan is started.
 - C. Adult Use Marihuana Establishment Ordinance Update: Director Bergman discussed two workshops that had been conducted with the City Commission. The map has been revised to provide more buffers.
9. Other Business: None.
10. Next Meeting: September 2, 2020 at 10:00 a.m.
11. Adjournment. **Motion** by Ramme to adjourn at 10:29 a.m. **Second** by Thorsen. **Motion Carried 6 to 0.**

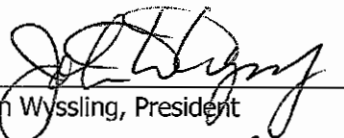

John Wyssling, President



Tim Erickson, Community Development Assistant



IRONWOOD

MICHIGAN | *Find Your North*

Proceedings of the Economic Development Corporation Meeting Wednesday, October 7, 2020

A Regular Meeting of the Economic Development Corporation (EDC) was held on Wednesday, October 7, 2020 at 10:00 A.M. via ZOOM

1. Chair Wyssling called the meeting to order at 10:04 a.m.
2. Recording of the Roll

MEMBER	Present		EXCUSED	NOT EXCUSED
	YES	NO		
Thorsen, Gina	X			
Lemke, Joseph		X	X	
Korpela, Nancy	X			
Sclafani, Velda	X			
Ramme, Dave	X			
Ruppe, Mark		X	X	
Schonberg, Bob		X	X	
Wyssling, John	X			
Gary Burnett		X	X	
Quorum	5	4	Quorum	

Also Present: Community Development Director Tom Bergman and Community Development Strategist Tim Erickson.

3. Approval of the August 5, 2020 Meeting Minutes:
Motion by Ramme to accept the August 5, 2020 meeting minutes. **Second** by Korpela. **Motion Carried 6 to 0.**
4. Approval of the Agenda
Motion by Ramme to accept the Agenda. **Second** by Thorsen. **Motion Carried 6 to 0.**
5. Citizens wishing to address the Corporation regarding Items on the Agenda (Three-minute limit):
None.

6. Citizens wishing to address the Corporation regarding items not on the Agenda (Three-minute limit): None.
7. Items for Discussion and Consideration.
 - A. COVID-19 Business Update: Director Bergman said that there wasn't too much to update for future grant opportunities. He doesn't expect the Federal government to provide any stimulus until after the election. Erickson discussed some issues with supply chain for local businesses but also said that consumer demand was up. They also talked about the real estate market.
 - B. Update on TIF District for Downtown: Director Bergman said that the Zoning Ordinance update needs to be completed before the TIF District can be started.
 - C. Adult Use Marihuana Establishment Ordinance Update: Director Bergman said that he is working on the application process. He also said that an odor nuisance ordinance and civil infraction ordinance will be presented at the next City Commission meeting. He discussed a lengthy application process for commercial marijuana facilities.
 - D. Zoning Ordinance Update (Industrial District Discussion): Director Bergman said that they were making progress with the Zoning Ordinance and will be coming to the EDC with some questions and direction. He asked the Corporation if the industrial park should expand to two zoning districts to separate lower impact industrial with higher impact industrial. The EDC discussed the need for both types of activities. They discussed creating a spec building for manufacturing or other light industrial manufacturing.
 - E. Update on Michigan Small Business Restart Grant: Director Bergman said that the City of Ironwood had over 30 businesses that received a grant.
8. Other Business: None.
9. Next Meeting: November 4, 2020 at 10:00 a.m.
10. Adjournment. **Motion** by Thorsen to adjourn at 10:29 a.m. **Second** by Ramme. **Motion Carried 6 to 0.**

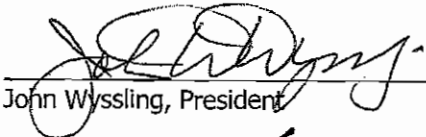

John Wyssling, President

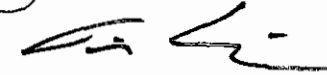

Tim Erickson, Community Development Assistant



IRONWOOD

MICHIGAN | *Find Your North*

Proceedings of the Economic Development Corporation Meeting Wednesday, January 13, 2021

A Regular Meeting of the Economic Development Corporation (EDC) was held on Wednesday, January 13, 2020 at 10:00 A.M. via ZOOM

1. Chair Wyssling called the meeting to order at 10:05 a.m.
2. Recording of the Roll

MEMBER	Present		EXCUSED	NOT EXCUSED
	YES	NO		
Thorsen, Gina	X			
Lemke, Joseph	X			
Korpela, Nancy	X			
Ramme, Dave	X			
Ruppe, Mark		X	X	
Schonberg, Bob	x			
Wyssling, John	X			
Gary Burnett	X			
Quorum	7	1	Quorum	

Also Present: Community Development Director Tom Bergman and Community Development Strategist Tim Erickson.

3. Approval of the November 4, 2020 Meeting Minutes:
Motion by Thorsen to accept the November 4, 2020 meeting minutes. **Second** by Korpela.
Motion Carried 6 to 0.
4. Approval of the Agenda
Motion by Lemke to accept the Agenda. **Second** by Thorsen. **Motion Carried 6 to 0.**
5. Citizens wishing to address the Corporation regarding Items on the Agenda (Three-minute limit):
None.

6. Citizens wishing to address the Corporation regarding items not on the Agenda (Three-minute limit): None.

7. Items for Discussion and Consideration.

A. 2021 Goals.

- I. Redevelopment Ready Communities Development and Priority Sites.
- II. MEDC Grants (i.e. Build to Suit Grant).
- III. Internal Marketing (Outreach and education for Hospitality Industry).

1. The EDC discussed adding the TIF District to the goals.

Adjournment. **Motion** by Schonberg to approve the 2021 goals with the addition of the TIF District for Downtown. **Second** by Thorsen. **Motion Carried 6 to 0.**

B. COVID-19 Business Update: Director Bergman discussed the financial opportunities for businesses to apply to receive relief funding. He discussed doing some press releases when funding becomes available. Thorsen asked about the health of the restaurant industry in Ironwood. Bergman talked about potentially create a short-term goal for when restaurants can open.

C. Update on TIF District for Downtown: Director Bergman said that the zoning ordinance needs to be updated first.

D. Adult Use Marihuana Establishment License Application Update: Director Bergman said that he had 16 total requests from 8 different applicants. The City has 45 days of review.

E. Zoning Ordinance Update: Director Bergman said that the zoning ordinance is about 75% complete. He is currently working on the zoning map and district language with the consultants. The Corporation will be receiving a draft with some highlighted areas to review and give input.

8. Other Business: None.

9. Next Meeting: February 3, 2021 at 10:00 a.m.

10. Adjournment. **Motion** by Korpela to adjourn at 10:35 a.m. **Second** by Lemke. **Motion Carried 5 to 0.**

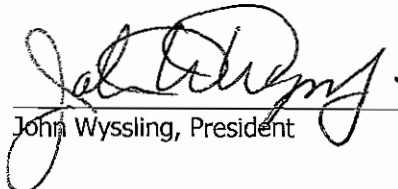
John Wyssling, President

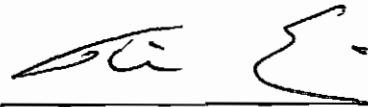

Tim Erickson, Community Development Assistant

Civic Center Meeting Minutes

4/5/21

1. Meeting called to order by Collins at 5:03 pm.
2. Roll Call: Collins, Gullan, Mildren, Moderson, Panosso, Re, Sommer, and Mgr. Sivula present.
3. Motion to approve the agenda made by Gullan, seconded by Moderson. Motion approved.
4. Motion to approve the minutes (no financials available) was made by Mildren, seconded by Gullan. Motion approved.
5. Citizens wishing to address the Board on items on the agenda: N/A
6. Citizens wishing to address the Board on items not on the agenda: N/A
7. Old Business:
 - A. Electrical Work and Approval of Bid: Discussion about the electrical work and subsequent bill(s) was held. Discussion included but wasn't limited to the work done for the ATM, jukebox/sound system, outlets, and the cost of the job(s).
 - i. Motion to approve both bills 1. \$1,385.00 and 2. \$480.00 for a total of \$1,865.00 was made by Mildren, seconded by Re. Roll call vote was as follows: Collins-yes, Gullan-yes, Moderson-yes, Panosso-yes, Sommer-yes, Re-yes, Mildren-yes. Motion approved.
 - B. Exterior Block Update: Discussion about the exterior block in the Northeast corner was held. Discussion included but wasn't limited to water issues still persisting in that corner, collaboration between Civic Center, City of Ironwood, Signal, and MMRMA continue in order to find solutions that best mitigate the water issues.
 - C. Rink Systems Inc.: Discussion about Rink Systems Inc. was held. Discussion included but wasn't limited to work still needs to be finished, clean-up done, and work being postponed due to worker quarantine.
 - i. Civic Center still needs insulation between the concessions area and the ice rink to mitigate heat loss; options are being investigated.

8. New Business:

- A. Budget Review and Approval: Discussion of the budget was held, but no action was taken. Per advice of City of Ironwood Treasurer, further discussion and approval will occur next month.
- B. Appliance and Furniture Update: Discussion and update of the appliances and furniture was held. Discussion included but wasn't limited to payments submitted/received, arrival/delivery dates, and Webstaurantstore.com's bid was lower than the approved amount because the correct benches were unavailable; new bill was \$14,126.01.
 - i. Appliances: will arrive in May.
 - ii. Furniture: no arrival date available.
- C. Painting of Rink Line Bids: Discussion of bids for the painting of the rink lines was held. Discussion included but wasn't limited to process and materials needed to paint the rink lines, two bids have been submitted, and when the painting can take place.

9. Other matters:

- A. Gullan—construction of the bench flooring will begin next week.
- B. Mildren—ideas for summer use: roller skating, roller blading, roller hockey, etc. and how that will affect the new painting of the lines and slab surface.
- C. Collins—each system within the Civic Center has been updated to the most state-of-the-art technology and everything is still coming together.

10. Next Regular Meeting Monday May 3rd at 5:00 pm at the Ironwood Memorial Building.

11. Adjournment: Motion to adjourn at 5:46 pm was made by Re, seconded by Gullan.

Motion approved.

**IRONWOOD HOUSING COMMISSION
REGULAR MEETING MINUTES
APRIL 13, 2021
PIONEER PARK APARTMENTS – COMMUNITY ROOM
515 E. VAUGHN STREET – IRONWOOD, MI. 49938**

The regular meeting of the Ironwood Housing Commission was held on April 13, 2021 in the Community Room at Pioneer Park Apartments at 515 E. Vaughn Street, Ironwood, MI. 49938.

Present: Annabelle O'Brien
Jim Peterson
Pat Niksich

Absent: Anne Davey
Adrienne Chase

1. Call to Order

The meeting was call to order by President O'Brien. Followed by the Pledge of Allegiance.

2. Minutes of March 9, 2021 Meeting

Motion by Niksich, Seconded by Peterson, Unanimously approved through roll call vote to approve minutes of the March 9, 2021 Meeting.

3. Old Business – None

4. New Business

4.1.1 Ironwood Housing Commission Commissioner's Handbook

Motion by Peterson, Seconded by Niksich, Unanimously approved through roll call vote to approve the newly updated Commissioner Handbook as of April 13, 2021.

5. Consent Agenda – “Information Only”

A-Current Vacancy Report

B-Account A/R Balance Report as of March 29, 2021

C-Bank Account Reconciliation Report as of Feb. 28, 2021

D-Supplementary Stmt. of Income & Expense as of February 28, 2021.

The Director provided information to the Board of Commissioners on the current Vacancy Report, the current A/R balance report as of March 29, 2021, the Bank Account Reconciliation report as of February 28, 2021, the Supplementary Statement of Income & Expense as of February 28, 2021. This report includes Revenue to Date, Expense to Date and the total unrestricted Net Position as of February 28, 2021.

6. Disbursements of Checks 20986 – 21028

Motion by Niksich, Seconded by Peterson, Unanimously approved through roll call vote to approve the Disbursements of checks 20986-21028.

7. Commissioner Comments

Niksich commented that she was glad the Commissioner Handbook was updated. The Director commented that the Commissioner Handbook was updated according to the Ironwood Housing Commissions most current By-Laws and with HUD's rules and regulations.

8. Public Comments

O'Brien commented on the possibility of installing a dog run in the back yard. The Director commented that she was going to have additional dog stations installed on the property. Doleshal commented on that she is not a smoker but maybe we should look into installing a smoking shack on the West side of the building for smokers. Thomas commented on that we should look into installing small windows on the wooden doors to the exits into the stairwells so people won't get hit with the door when opened. Peterson commented on that we should pass out notices to tenants so they are aware of how Public participation in meetings is handled.

9. Adjournment

Motion by Peterson, Seconded by Niksich, Unanimously approved through roll call vote to adjourn the meeting. The meeting adjourned at 4:45 p.m.

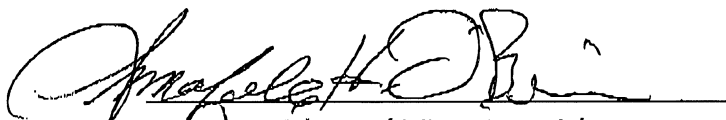

President / Vice-President

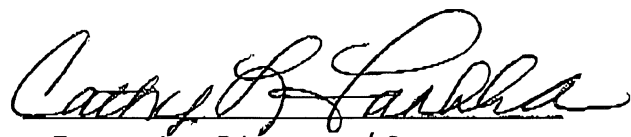

Executive Director / Secretary



City of Ironwood
213 S. Marquette St.
Ironwood, MI 49938

Phone: (906) 932-5050
Fax: (906) 932-5745
www.cityofironwood.org

IRONWOOD

MICHIGAN | *Find Your North*

SUMMARY OF MARCH 2021 FINANCIAL REPORTS

The Revenue and Expenditure Report and the Cash and Investment Summary Report are included in the agenda packet for April 26, 2021. Following is a summary of each report.

Revenue and Expenditure Report

As of March 31, 2021, we are approximately 75% through our current fiscal year. The revenues and expenditures of most funds are in-line with this benchmark. Major Funds with large variations from the 75% benchmark (and applicable reasoning) are as follows:

1. Major and Local Street Funds: Expenditures at approximately 53% - We have a large amount budgeted for street construction and maintenance. This activity will pick over the next few months. Winter maintenance and snow hauling expenditures are less than normal due to below average snowfall.
2. Water Fund: Expenditures at 63% - We have a large amount budgeted for service line replacement, which is required by the State of Michigan. This effort has begun and will continue in the spring. We have also submitted grant applications to help fund this work.
3. Sewer Fund: Expenditures at 64% - We have a large amount budgeted for sewer main replacement. This project has recently started.

Cash and Investment Summary Report

The Cash and Investment Summary Report shows the activity for the month of March, sorted by fund. Notable items are as follows:

1. General Fund Cash: Account balance increased due to receiving a large grant reimbursement for the Downtown Square Project.
2. Retiree Health Care Fund – MERS Investments: Account balance increased due to the recording of the third quarter investment gain.



This Institution is an Equal Opportunity Provider, Employer and Housing Employer/Lender



GL NUMBER	DESCRIPTION	2020-21 AMENDED BUDGET	YTD BALANCE	
			03/31/2021 NORMAL (ABNORMAL)	% BDGT USED
Fund 101 - GENERAL FUND				
Revenues				
101-000.000-403.000	CURRENT PROPERTY TAXES	1,800,000.00	1,350,000.00	75.00
101-000.000-410.000	PERSONAL PROPERTY TAX	5,000.00	0.00	0.00
101-000.000-426.000	PAYMENTS IN LIEU OF TAXES	7,000.00	0.00	0.00
101-000.000-448.000	COLLECTION FEES	72,000.00	103,830.41	144.21
101-000.000-448.002	SCHOOL TAX COL FEES	12,000.00	13,008.64	108.41
101-000.000-448.003	GOISD TAX COL FEES	3,000.00	3,078.00	102.60
101-000.000-451.000	BUSINESS LICENSES AND PERMITS	10,000.00	10,620.00	106.20
101-000.000-467.000	CABLE TV FRANCHISE FEE	52,000.00	26,642.60	51.24
101-000.000-477.000	RENTAL REGISTRATION FEES	500.00	30.00	6.00
101-000.000-478.000	MARIHUANA LICENSE/APPLICATION FEES	0.00	24,000.00	100.00
101-000.000-499.000	PUBLIC SAFETY REVENUES	45,000.00	46,421.56	103.16
101-000.000-499.001	SALVAGE REVENUES	10,000.00	3,707.00	37.07
101-000.000-528.000	OTHER FEDERAL GRANTS	19,000.00	193,448.00	1,018.15
101-000.000-530.000	FEDERAL GRANTS	1,343,000.00	1,285,511.13	95.72
101-000.000-532.000	STATE GRANTS	285,000.00	7,000.00	2.46
101-000.000-533.000	MMRMA GRANTS	6,000.00	0.00	0.00
101-000.000-534.000	GRANTS - OTHER	9,500.00	5,000.00	52.63
101-000.000-573.000	LOCAL COMM. STABILIZATION SHARE APPROP	5,000.00	26,133.86	522.68
101-000.000-575.000	SALES & USE TAX-STATE	665,000.00	584,909.00	87.96
101-000.000-577.000	LIQOUR LICENSES	6,000.00	6,940.55	99.01
101-000.000-612.000	ZONING APPLICATION FEE	1,000.00	5,750.00	575.00
101-000.000-614.000	OTHER CHARGES/FEES	0.00	183.70	100.00
101-000.000-617.000	DEED PREPARATION FEES	1,000.00	0.00	0.00
101-000.000-619.000	MISC REC PENALTY FEE	0.00	223.41	100.00
101-000.000-625.000	BLDG INSPECTION PERMITS	7,000.00	5,325.00	76.07
101-000.000-633.000	ADMINISTRATION-WATER & SEWER	72,000.00	54,000.00	75.00
101-000.000-634.000	ADMINISTRATION-EQUIPMENT FUND	12,000.00	9,000.00	75.00
101-000.000-635.000	ADMINISTRATION-STREET FUNDS	18,000.00	13,500.00	75.00
101-000.000-636.000	MARKETING FEES - ITC	20,000.00	12,409.11	62.05
101-000.000-637.000	IWD HOUSING COMM ADMIN FEE	3,500.00	4,008.98	114.54
101-000.000-640.000	TAX/ASSESS REVENUES	1,000.00	2,300.00	230.00
101-000.000-642.001	ORDINANCE VIOLATION FEE	6,000.00	10,182.85	169.71
101-000.000-651.000	USE AND ADMISSION FEES	3,200.00	1,601.00	50.03
101-000.000-651.005	DEPOT PARK FEES	200.00	50.00	25.00
101-000.000-651.006	NORRIE PARK PAVILLION RENT FEES	100.00	25.00	25.00
101-000.000-652.000	CURRY PARK FEES	15,000.00	12,954.00	86.36
101-000.000-664.000	INTEREST AND DIVIDENDS	50,000.00	41,949.77	83.90
101-000.000-667.000	RENTAL INCOME - AUDITORIUM	2,000.00	800.00	40.00
101-000.000-668.000	RENTS-MEMORIAL BUILDING	71,200.00	56,514.41	79.37
101-000.000-670.000	RENTS GARAGE	81,000.00	60,750.00	75.00
101-000.000-671.000	RENTS OTHER CITY PROPERTY	5,300.00	903.00	17.04
101-000.000-673.000	SALES OF FIXED ASSETS	0.00	4,500.00	100.00
101-000.000-674.000	BRANDING MERCHANDISE SALES	1,000.00	215.00	21.50
101-000.000-675.000	CONTRIBUTIONS AND DONATION	0.00	100.00	100.00
101-000.000-675.023	DONATIONS - IRON BELLE TRAIL	4,000.00	7,240.00	181.00
101-000.000-675.024	DONATIONS - MINERS PARK BIKE TRAILS	53,000.00	40,000.00	75.47
101-000.000-689.002	USE OF RESTRICTED FUND BALANC	18,000.00	0.00	0.00
101-000.000-689.003	USE OF ASSIGNED FUND BALANCE	374,000.00	0.00	0.00
101-000.000-689.005	USE OF COMMITTED FUND BALANCE	586,000.00	0.00	0.00
101-000.000-690.000	REFUND AND REBATES-INSURANCE	0.00	79,163.00	100.00
101-000.000-692.000	MISCELLANEOUS INCOME	0.00	2,576.89	100.00
101-000.000-692.002	HUNTING REGISTRATION	500.00	120.00	24.00
101-000.000-694.000	CASH OVER/SHORT	0.00	80.00	100.00
TOTAL REVENUES		5,761,000.00	4,115,705.87	71.44

Expenditures

101.000	CITY COMMISSION	43,000.00	33,416.91	77.71
172.000	CITY MANAGER	121,000.00	75,584.87	62.47
191.000	ELECTIONS	12,000.00	9,125.88	76.05
191.192	ELECTIONS COVID-19	0.00	120.95	100.00
201.000	FINANCIAL DEPT	182,000.00	125,085.94	68.73
205.000	CITY TREASURER	44,000.00	27,376.37	62.22
209.000	CITY ASSESSOR	126,000.00	94,490.75	74.99
210.000	COMPUTER/EQUIPMENT	89,000.00	79,417.74	89.23
210.192	COMPUTER/IT COVID-19	0.00	2,576.10	100.00
215.000	CITY CLERK	180,000.00	120,305.22	66.84
247.000	BOARD OF REVIEW	2,000.00	1,124.87	56.24
249.000	BUILDING INSPECTION	51,000.00	25,818.53	50.62
265.000	MEMORIAL BUILDING	342,000.00	115,995.76	33.92
265.192	MEMORIAL BUILDING COVID-19	0.00	6,529.96	100.00
339.000	VOLUNTEER FIRE RELATED ACTIVITIES	19,000.00	11,077.20	58.30
345.000	PUBLIC SAFETY DEPARTMENT	1,165,000.00	833,217.78	71.52
345.192	PUBLIC SAFETY COVID-19	0.00	7,931.07	100.00
346.000	DRUG ENFORCEMENT	5,000.00	6,808.90	136.18
400.000	COMMUNITY DEVELOPMENT	221,000.00	126,061.60	57.04

04/20/2021 12:55 PM
 User: PAUL
 DB: Ironwood

REVENUE AND EXPENDITURE REPORT FOR CITY OF IRONWOOD
 PERIOD ENDING 03/31/2021
 % Fiscal Year Completed: 75.07

GL NUMBER	DESCRIPTION	2020-21 AMENDED BUDGET	YTD BALANCE		% BGD USED
			NORMAL	03/31/2021 (ABNORMAL)	
Fund 101 - GENERAL FUND					
Expenditures					
412.000	CODE ENFORCEMENT	253,000.00		164,674.93	65.09
412.192	CODE ENFORCEMENT COVID-19	0.00		360.09	100.00
448.000	STREET LIGHTING	93,000.00		63,503.18	68.28
529.000	OTHER SANITATION ACTIVITIES	37,000.00		16,216.70	43.83
529.001	GAS PLANT SITE	7,000.00		579.55	8.28
716.000	MARKETING - ITC	20,000.00		13,877.41	69.39
716.192	MARKETING - ITC COVID-19	0.00		360.09	100.00
720.000	COMMUNITY ASSISTANCE	0.00		513.47	100.00
720.001	COMMUNITY ASSISTANCE - CIVIC CENTER	0.00		4,533.21	100.00
720.002	COMMUNITY ASSISTANCE - LIBRARY	0.00		36.16	100.00
751.000	PARKS MAINTENANCE	148,000.00		58,104.03	39.26
751.002	PARKS - MINE SHAFT SAFETY	22,000.00		116.20	0.53
751.005	CURRY PARK	52,000.00		122.91	0.24
751.007	DEPOT PARK	0.00		3,564.28	100.00
751.009	MT ZION ENHANCEMENT PROJECT	13,000.00		74.64	0.57
751.010	BELTLINE TRAIL GRANT PROJECT - PHASE 1	73,000.00		4,191.50	5.74
751.011	MINERS PARK BIKE TRAIL GRANT PROJECT	197,000.00		4,789.68	2.43
751.012	DOWNTOWN SQUARE	1,500,000.00		1,449,400.23	96.63
751.013	BELTLINE TRAIL GRANT PROJECT - PHASE 2	20,000.00		0.00	0.00
751.192	PARKS MAINTENANCE COVID-19	0.00		6,985.65	100.00
757.001	NON-MOTORIZED TRAIL - IRON BELLE	16,000.00		19,241.30	120.26
851.000	INSURANCE-FRINGS-DUES	38,000.00		28,915.59	76.09
890.000	PROGRAMS	9,000.00		8,560.00	95.11
893.000	LABOR RELATIONS	5,000.00		264.50	5.29
965.000	APPROPRIATIONS TO OTHER FUNDS	656,000.00		235,948.39	35.97
TOTAL EXPENDITURES		5,761,000.00		3,787,000.09	65.74
Fund 101 - GENERAL FUND:					
TOTAL REVENUES		5,761,000.00		4,115,705.87	71.44
TOTAL EXPENDITURES		5,761,000.00		3,787,000.09	65.74
NET OF REVENUES & EXPENDITURES		0.00		328,705.78	100.00

04/20/2021 12:55 PM
 User: PAUL
 DB: Ironwood

REVENUE AND EXPENDITURE REPORT FOR CITY OF IRONWOOD
 PERIOD ENDING 03/31/2021
 % Fiscal Year Completed: 75.07

GL NUMBER	DESCRIPTION	2020-21 AMENDED BUDGET	YTD BALANCE	
			03/31/2021 NORMAL (ABNORMAL)	% BDGT USED
Fund 202 - MAJOR STREET FUND				
Revenues				
202-000.000-530.000	FEDERAL GRANTS	311,000.00	308,882.15	99.32
202-000.000-545.000	STS ROUTINE MAINT	170,000.00	142,377.83	83.75
202-000.000-546.000	STATE GRANTS - ACT 51	692,000.00	540,855.09	78.16
202-000.000-546.001	METRO PA 48 REV	9,000.00	0.00	0.00
202-000.000-547.000	SNOW FUNDS	40,000.00	60,067.65	150.17
202-000.000-688.000	TRANSFER FROM GENERAL FUND	30,000.00	0.00	0.00
202-000.000-688.004	TRANSFER FROM DIDA	1,200.00	900.00	75.00
202-000.000-689.003	USE OF ASSIGNED FUND BALANCE	270,800.00	0.00	0.00
202-000.000-692.000	MISCELLANEOUS INCOME	0.00	287.70	100.00
TOTAL REVENUES		1,524,000.00	1,053,370.42	69.12
Expenditures				
446.000	HIGHWAY, STREETS, BRIDGES	652,000.00	421,596.85	64.66
447.001	STREETSCAPING	2,500.00	125.93	5.04
447.002	STREETSCAPING-US	100.00	6,300.60	6,300.60
447.003	STREETSCAPING-BR	13,200.00	12,054.20	91.32
485.002	TRAFFIC SIGNALS-US	1,000.00	269.79	26.98
486.001	SURFACE MAINTENANCE	261,000.00	22,458.13	8.60
486.002	SURFACE MAINTENANCE-US	8,900.00	1,305.67	14.67
486.003	SURFACE MAINTENANCE-BR	3,800.00	3,635.74	95.68
488.001	SWEEPING MAJOR	44,100.00	14,221.93	32.25
488.002	SWEEPING -US	5,500.00	0.00	0.00
488.003	SWEEPING -BR	1,800.00	0.00	0.00
491.001	DRAINAGE - BACKSLOPES	19,800.00	20.88	0.11
491.002	DRAINAGE AND BACKSLOPES-US	1,200.00	0.00	0.00
494.001	TRAFFIC SIGNS	15,500.00	8,761.10	56.52
494.002	TRAFFIC SIGNS-US	2,000.00	255.66	12.78
494.003	TRAFFIC SIGNS-BR	3,300.00	0.00	0.00
495.003	FLOWER BASKET WATERING-BR	7,400.00	10,193.52	137.75
497.001	WINTER MAINTENANCE	126,900.00	85,083.50	67.05
497.002	WINTER MAINTENANCE-US	43,100.00	21,917.16	50.85
497.003	WINTER MAINTENANCE-BR	28,500.00	19,223.46	67.45
498.001	SNOW HAULING	86,000.00	26,156.01	30.41
498.002	SNOW HAULING-US	32,900.00	13,199.55	40.12
498.003	SNOW HAULING-BR	31,500.00	14,702.18	46.67
502.000	LEAVE AND BENEFITS	63,800.00	35,687.65	55.94
503.000	GENERAL AND ADMINISTRATIVE	40,600.00	27,550.19	67.86
503.172	ADM/ CM	8,500.00	6,105.33	71.83
503.192	GENERAL/ADMIN COVID-19	0.00	21.18	100.00
569.000	DEBT RETIREMENT	19,100.00	19,480.91	101.99
TOTAL EXPENDITURES		1,524,000.00	770,327.12	50.55
Fund 202 - MAJOR STREET FUND:				
TOTAL REVENUES		1,524,000.00	1,053,370.42	69.12
TOTAL EXPENDITURES		1,524,000.00	770,327.12	50.55
NET OF REVENUES & EXPENDITURES		0.00	283,043.30	100.00

04/20/2021 12:55 PM
 User: PAUL
 DB: Ironwood

REVENUE AND EXPENDITURE REPORT FOR CITY OF IRONWOOD
 PERIOD ENDING 03/31/2021
 % Fiscal Year Completed: 75.07

GL NUMBER	DESCRIPTION	2020-21 AMENDED BUDGET	YTD BALANCE		% BDGT USED
			NORMAL	03/31/2021 (ABNORMAL)	
Fund 203 - LOCAL STREET FUND					
Revenues					
203-000.000-546.000	STATE GRANTS - ACT 51	258,000.00		201,895.69	78.25
203-000.000-546.001	METRO PA 48 REV	18,000.00		0.00	0.00
203-000.000-547.000	SNOW FUNDS	30,000.00		66,838.14	222.79
203-000.000-664.000	INTEREST AND DIVIDENDS	0.00		214.01	100.00
203-000.000-688.000	TRANSFER FROM GENERAL FUND	559,000.00		216,129.08	38.66
TOTAL REVENUES		865,000.00		485,076.92	56.08
Expenditures					
446.000	HIGHWAY, STREETS, BRIDGES	200,000.00		105,975.08	52.99
486.001	SURFACE MAINTENANCE	206,100.00		62,463.64	30.31
488.001	SWEEPING MAJOR	8,800.00		1,841.89	20.93
491.001	DRAINAGE - BACKSLOPES	4,500.00		326.01	7.24
494.001	TRAFFIC SIGNS	15,100.00		19,935.74	132.02
497.001	WINTER MAINTENANCE	163,300.00		97,774.13	59.87
498.001	SNOW HAULING	34,200.00		8,379.91	24.50
502.000	LEAVE AND BENEFITS	59,500.00		35,602.17	59.84
503.000	GENERAL AND ADMINISTRATIVE	43,800.00		28,536.78	65.15
503.172	ADM/ CM	8,500.00		6,105.41	71.83
503.192	GENERAL/ADMIN COVID-19	0.00		21.16	100.00
569.000	DEBT RETIREMENT	121,200.00		118,115.00	97.45
TOTAL EXPENDITURES		865,000.00		485,076.92	56.08
Fund 203 - LOCAL STREET FUND:					
TOTAL REVENUES		865,000.00		485,076.92	56.08
TOTAL EXPENDITURES		865,000.00		485,076.92	56.08
NET OF REVENUES & EXPENDITURES		0.00		0.00	0.00

04/20/2021 12:55 PM
 User: PAUL
 DB: Ironwood

REVENUE AND EXPENDITURE REPORT FOR CITY OF IRONWOOD
 PERIOD ENDING 03/31/2021
 % Fiscal Year Completed: 75.07

GL NUMBER	DESCRIPTION	2020-21 AMENDED BUDGET	YTD BALANCE		% BDGT USED
			NORMAL	03/31/2021 (ABNORMAL)	
Fund 216 - VOLUNTEER FIRE DEPARTMENT					
Revenues					
216-000.000-647.001	POP MACHINE REVENUE	100.00		0.00	0.00
216-000.000-689.003	USE OF ASSIGNED FUND BALANCE	1,900.00		0.00	0.00
TOTAL REVENUES		2,000.00		0.00	0.00
Expenditures					
339.000	VOLUNTEER FIRE RELATED ACTIVITIES	2,000.00		119.00	5.95
TOTAL EXPENDITURES		2,000.00		119.00	5.95
Fund 216 - VOLUNTEER FIRE DEPARTMENT:					
TOTAL REVENUES		2,000.00		0.00	0.00
TOTAL EXPENDITURES		2,000.00		119.00	5.95
NET OF REVENUES & EXPENDITURES		0.00		(119.00)	100.00

04/20/2021 12:55 PM
 User: PAUL
 DB: Ironwood

REVENUE AND EXPENDITURE REPORT FOR CITY OF IRONWOOD
 PERIOD ENDING 03/31/2021
 % Fiscal Year Completed: 75.07

GL NUMBER	DESCRIPTION	2020-21 AMENDED BUDGET	YTD BALANCE		% BGD USED
			NORMAL	03/31/2021 (ABNORMAL)	
Fund 271 - LIBRARY FUND					
Revenues					
271-000.000-403.000	CURRENT PROPERTY TAXES	90,000.00		67,500.00	75.00
271-000.000-410.000	PERSONAL PROPERTY TAX	300.00		0.00	0.00
271-000.000-426.000	PAYMENTS IN LIEU OF TAXES	300.00		0.00	0.00
271-000.000-528.000	OTHER FEDERAL GRANTS	0.00		331.12	100.00
271-000.000-530.000	FEDERAL GRANTS	0.00		1,990.67	100.00
271-000.000-551.000	UNITED WAY GRANT	0.00		500.00	100.00
271-000.000-566.000	STATE GRANTS-LIBRARY	3,000.00		2,306.32	76.88
271-000.000-566.002	BANFIELD GRANT	2,000.00		2,000.00	100.00
271-000.000-566.011	CREATIVE PROGRAMS	0.00		30.40	100.00
271-000.000-566.027	LSTA SUMMER GRANT	2,000.00		0.00	0.00
271-000.000-566.029	MCACA MINI GRANT	700.00		650.00	92.86
271-000.000-566.030	MICHIGAN HUMANITIES H.O.P.E. GRANT	5,100.00		5,100.00	100.00
271-000.000-573.000	LOCAL COMM. STABILIZATION SHARE APPROP	300.00		907.70	302.57
271-000.000-590.000	ERWIN TOWNSHIP CONTRACT	1,000.00		1,000.00	100.00
271-000.000-642.000	CHARGES SALES & SERVICE	1,500.00		332.65	22.18
271-000.000-647.000	FUND RAISING REVENUE	3,000.00		40.50	1.35
271-000.000-649.000	NON-RESIDENT FEES	2,000.00		722.00	36.10
271-000.000-650.000	SALES OF BOOKS	400.00		39.00	9.75
271-000.000-651.000	USE AND ADMISSION FEES	200.00		15.00	7.50
271-000.000-656.000	FINES AND FORFEITURES	1,000.00		232.77	23.28
271-000.000-657.000	PENAL FINES	15,000.00		0.00	0.00
271-000.000-664.000	INTEREST AND DIVIDENDS	500.00		24.54	4.91
271-000.000-675.000	CONTRIBUTIONS AND DONATION	3,500.00		3,248.12	92.80
271-000.000-675.001	DONATIONS- BLDG FUND	500.00		255.50	51.10
271-000.000-675.006	DONATIONS ANNUAL APPEAL	4,500.00		9,087.45	201.94
271-000.000-675.008	BOOK \$ APPEAL	300.00		210.00	70.00
271-000.000-675.010	DONATIONS - FRIENDS OF LIBRAR	4,600.00		2,604.00	56.61
271-000.000-675.012	STARK FOUNDATION	3,400.00		3,400.00	100.00
271-000.000-687.000	REFUNDS AND REBATES	300.00		845.00	281.67
271-000.000-689.002	USE OF RESTRICTED FUND BALANC	7,500.00		0.00	0.00
271-000.000-689.003	USE OF ASSIGNED FUND BALANCE	1,000.00		0.00	0.00
TOTAL REVENUES		153,900.00		103,372.74	67.17
Expenditures					
790.000	LIBRARY	153,900.00		102,230.80	66.43
790.192	LIBRARY COVID-19	0.00		127.01	100.00
TOTAL EXPENDITURES		153,900.00		102,357.81	66.51
Fund 271 - LIBRARY FUND:					
TOTAL REVENUES		153,900.00		103,372.74	67.17
TOTAL EXPENDITURES		153,900.00		102,357.81	66.51
NET OF REVENUES & EXPENDITURES		0.00		1,014.93	100.00

04/20/2021 12:55 PM
 User: PAUL
 DB: Ironwood

REVENUE AND EXPENDITURE REPORT FOR CITY OF IRONWOOD
 PERIOD ENDING 03/31/2021
 % Fiscal Year Completed: 75.07

GL NUMBER	DESCRIPTION	2020-21 AMENDED BUDGET	YTD BALANCE		% BDGT USED
			NORMAL	03/31/2021 (ABNORMAL)	
Fund 273 - NEIGHBORHOOD ENHANCEMENT PROGRAM					
Revenues					
273-000.000-529.000	HOMEOWNERS SHARE GRANT	16,000.00		5,230.00	32.69
273-000.000-532.000	STATE GRANTS	30,000.00		0.00	0.00
273-000.000-688.000	TRANSFER FROM GENERAL FUND	1,000.00		0.00	0.00
TOTAL REVENUES		47,000.00		5,230.00	11.13
Expenditures					
690.000	COMM DEV REHAB	47,000.00		30.00	0.06
TOTAL EXPENDITURES		47,000.00		30.00	0.06
Fund 273 - NEIGHBORHOOD ENHANCEMENT PROGRAM:					
TOTAL REVENUES		47,000.00		5,230.00	11.13
TOTAL EXPENDITURES		47,000.00		30.00	0.06
NET OF REVENUES & EXPENDITURES		0.00		5,200.00	100.00

04/20/2021 12:55 PM
 User: PAUL
 DB: Ironwood

REVENUE AND EXPENDITURE REPORT FOR CITY OF IRONWOOD
 PERIOD ENDING 03/31/2021
 % Fiscal Year Completed: 75.07

GL NUMBER	DESCRIPTION	2020-21 AMENDED BUDGET	YTD BALANCE		% BDGT USED
			NORMAL	03/31/2021 (ABNORMAL)	
Fund 352 - 2015 STREET BOND DEBT SERVICE FUND					
Revenues					
352-000.000-403.000	CURRENT PROPERTY TAXES	180,000.00		139,500.00	77.50
352-000.000-573.000	LOCAL COMM. STABILIZATION SHARE APPROP	0.00		1,879.68	100.00
352-000.000-664.000	INTEREST AND DIVIDENDS	0.00		583.08	100.00
TOTAL REVENUES		180,000.00		141,962.76	78.87
Expenditures					
557.000	ADMINISTRATION & OVERHEAD	4,000.00		469.35	11.73
569.000	DEBT RETIREMENT	176,000.00		176,525.00	100.30
TOTAL EXPENDITURES		180,000.00		176,994.35	98.33
Fund 352 - 2015 STREET BOND DEBT SERVICE FUND:					
TOTAL REVENUES		180,000.00		141,962.76	78.87
TOTAL EXPENDITURES		180,000.00		176,994.35	98.33
NET OF REVENUES & EXPENDITURES		0.00		(35,031.59)	100.00

04/20/2021 12:55 PM
 User: PAUL
 DB: Ironwood

REVENUE AND EXPENDITURE REPORT FOR CITY OF IRONWOOD
 PERIOD ENDING 03/31/2021
 % Fiscal Year Completed: 75.07

GL NUMBER	DESCRIPTION	2020-21 AMENDED BUDGET	YTD BALANCE		% BDGT USED
			NORMAL	03/31/2021 (ABNORMAL)	
Fund 401 - MEMORIAL BUILDING DEBT SERVICE FUND					
Revenues					
401-000.000-664.000	INTEREST AND DIVIDENDS	0.00		19.40	100.00
401-000.000-689.002	USE OF RESTRICTED FUND BALANC	2,000.00		0.00	0.00
TOTAL REVENUES		2,000.00		19.40	0.97
Expenditures					
145.000	BUILDING FUND	2,000.00		300.00	15.00
TOTAL EXPENDITURES		2,000.00		300.00	15.00
Fund 401 - MEMORIAL BUILDING DEBT SERVICE FUND:					
TOTAL REVENUES		2,000.00		19.40	0.97
TOTAL EXPENDITURES		2,000.00		300.00	15.00
NET OF REVENUES & EXPENDITURES		0.00		(280.60)	100.00

04/20/2021 12:55 PM
 User: PAUL
 DB: Ironwood

REVENUE AND EXPENDITURE REPORT FOR CITY OF IRONWOOD
 PERIOD ENDING 03/31/2021
 % Fiscal Year Completed: 75.07

GL NUMBER	DESCRIPTION	2020-21 AMENDED BUDGET	YTD BALANCE		% BDGT USED
			NORMAL	03/31/2021 (ABNORMAL)	
Fund 593 - CIVIC CENTER					
Revenues					
593-000.000-403.000	CURRENT PROPERTY TAXES	94,000.00		86,056.10	91.55
593-000.000-410.000	PERSONAL PROPERTY TAX	300.00		0.00	0.00
593-000.000-426.000	PAYMENTS IN LIEU OF TAXES	300.00		0.00	0.00
593-000.000-573.000	LOCAL COMM. STABILIZATION SHARE APPROP	500.00		939.84	187.97
593-000.000-647.001	POP MACHINE REVENUE	600.00		0.00	0.00
593-000.000-647.003	JUKEBOX REVENUE	200.00		0.00	0.00
593-000.000-651.000	USE AND ADMISSION FEES	11,000.00		0.00	0.00
593-000.000-651.001	SKATE SHARPENING	1,500.00		0.00	0.00
593-000.000-651.002	CONCESSION REVENUES	13,000.00		0.00	0.00
593-000.000-664.000	INTEREST AND DIVIDENDS	100.00		78.30	78.30
593-000.000-667.000	RENTAL INCOME	3,000.00		0.00	0.00
593-000.000-669.000	ADVERTISING REVENUES	500.00		0.00	0.00
593-000.000-673.000	SALES OF FIXED ASSETS	0.00		2,023.50	100.00
593-000.000-675.000	CONTRIBUTIONS AND DONATION	0.00		51,059.91	100.00
593-000.000-692.000	MISCELLANEOUS INCOME	0.00		102.00	100.00
TOTAL REVENUES		125,000.00		140,259.65	112.21
Expenditures					
805.000	CIVIC CENTER	125,000.00		78,208.62	62.57
805.192	CIVIC CENTER COVID-19	0.00		1,449.13	100.00
TOTAL EXPENDITURES		125,000.00		79,657.75	63.73
Fund 593 - CIVIC CENTER:					
TOTAL REVENUES		125,000.00		140,259.65	112.21
TOTAL EXPENDITURES		125,000.00		79,657.75	63.73
NET OF REVENUES & EXPENDITURES		0.00		60,601.90	100.00

04/20/2021 12:55 PM
 User: PAUL
 DB: Ironwood

REVENUE AND EXPENDITURE REPORT FOR CITY OF IRONWOOD
 PERIOD ENDING 03/31/2021
 % Fiscal Year Completed: 75.07

GL NUMBER	DESCRIPTION	2020-21 AMENDED BUDGET	YTD BALANCE		% BDGT USED
			NORMAL	03/31/2021 (ABNORMAL)	
Fund 640 - EQUIPMENT FUND					
Revenues					
640-000.000-530.000	FEDERAL GRANTS	0.00		58,200.00	100.00
640-000.000-644.000	EQUIPMENT RENTAL	619,000.00		485,196.49	78.38
640-000.000-664.000	INTEREST AND DIVIDENDS	5,000.00		140.33	2.81
640-000.000-673.000	SALES OF FIXED ASSETS	0.00		36,088.00	100.00
640-000.000-690.001	INSURANCE CLAIMS RECEIVED	0.00		2,361.40	100.00
TOTAL REVENUES		624,000.00		581,986.22	93.27
Expenditures					
557.000	ADMINISTRATION & OVERHEAD	263,000.00		153,957.38	58.54
557.172	ADM/ CM	2,900.00		2,035.06	70.17
557.192	ADMIN/OH COVID-19	0.00		1,183.66	100.00
895.000	DIRECT EQUIPMENT EXPENSE	220,100.00		159,341.90	72.40
896.000	DEPRECIATION	138,000.00		90,824.04	65.81
TOTAL EXPENDITURES		624,000.00		407,342.04	65.28
Fund 640 - EQUIPMENT FUND:					
TOTAL REVENUES		624,000.00		581,986.22	93.27
TOTAL EXPENDITURES		624,000.00		407,342.04	65.28
NET OF REVENUES & EXPENDITURES		0.00		174,644.18	100.00

04/20/2021 12:55 PM
 User: PAUL
 DB: Ironwood

REVENUE AND EXPENDITURE REPORT FOR CITY OF IRONWOOD
 PERIOD ENDING 03/31/2021
 % Fiscal Year Completed: 75.07

GL NUMBER	DESCRIPTION	2020-21 AMENDED BUDGET	YTD BALANCE	% BDGT USED
			03/31/2021 NORMAL (ABNORMAL)	
Fund 675 - WATER UTILITY FUND				
Revenues				
675-000.000-532.000	STATE GRANTS	500.00	0.00	0.00
675-000.000-602.000	WATER CHARGES-USAGE	1,689,000.00	1,275,439.85	75.51
675-000.000-613.000	TURN ON/OFF FEES	30,000.00	1,125.00	3.75
675-000.000-615.000	UTILITY BILL PENALTIES	27,500.00	991.67	3.61
675-000.000-616.000	NSF FEE	1,500.00	825.00	55.00
675-000.000-618.000	GARBAGE CHARGES	375,000.00	281,972.35	75.19
675-000.000-619.000	MISC REC PENALTY FEE	200.00	0.00	0.00
675-000.000-620.000	GARBAGE TAGS	300.00	397.50	132.50
675-000.000-664.000	INTEREST AND DIVIDENDS	5,000.00	1,823.73	36.47
675-000.000-689.004	USE OF UNRESTRICTED NET ASSETS	90,000.00	0.00	0.00
675-000.000-692.000	MISCELLANEOUS INCOME	0.00	70.00	100.00
TOTAL REVENUES		2,219,000.00	1,562,645.10	70.42
Expenditures				
521.000	GARBAGE COLLECTION	351,800.00	227,597.49	64.70
550.000	WELLS	500.00	0.00	0.00
551.000	PUMPING	289,600.00	213,601.06	73.76
553.000	TRANSMISSION AND DISTRIBUTION	302,700.00	162,763.41	53.77
553.001	TRANSMISSION AND DIST - WATER BREAKS	67,600.00	101,626.12	150.33
553.002	TRANSMISSION AND DIST - EMERGENCY RESP.	0.00	895.09	100.00
553.003	SERVICE LINES	270,800.00	53,416.60	19.73
554.000	METER SETS, REMOVALS & REPAIRS	87,400.00	48,837.49	55.88
556.000	CUSTOMER ACCOUNTING & COLLECT	84,700.00	57,085.83	67.40
557.000	ADMINISTRATION & OVERHEAD	401,600.00	223,865.08	55.74
557.172	ADM/ CM	9,300.00	6,105.43	65.65
557.192	ADMIN/OH COVID-19	0.00	673.74	100.00
896.000	DEPRECIATION	353,000.00	291,851.73	82.68
TOTAL EXPENDITURES		2,219,000.00	1,388,319.07	62.57
Fund 675 - WATER UTILITY FUND:				
TOTAL REVENUES		2,219,000.00	1,562,645.10	70.42
TOTAL EXPENDITURES		2,219,000.00	1,388,319.07	62.57
NET OF REVENUES & EXPENDITURES		0.00	174,326.03	100.00

04/20/2021 12:55 PM
 User: PAUL
 DB: Ironwood

REVENUE AND EXPENDITURE REPORT FOR CITY OF IRONWOOD
 PERIOD ENDING 03/31/2021
 % Fiscal Year Completed: 75.07

GL NUMBER	DESCRIPTION	2020-21 AMENDED BUDGET	YTD BALANCE	% BGD USED
			03/31/2021 NORMAL (ABNORMAL)	
Fund 676 - SEWER UTILITY FUND				
Revenues				
676-000.000-610.000	SEWER CHARGES-USAGE	2,025,000.00	1,566,776.92	77.37
676-000.000-615.000	UTILITY BILL PENALTIES	28,000.00	0.00	0.00
676-000.000-664.000	INTEREST AND DIVIDENDS	0.00	1,382.40	100.00
676-000.000-692.000	MISCELLANEOUS INCOME	0.00	5,085.88	100.00
TOTAL REVENUES		2,053,000.00	1,573,245.20	76.63
Expenditures				
554.000	METER SETS, REMOVALS & REPAIRS	84,400.00	45,818.77	54.29
556.000	CUSTOMER ACCOUNTING & COLLECT	81,700.00	56,603.90	69.28
557.000	ADMINISTRATION & OVERHEAD	292,500.00	152,637.48	52.18
557.172	ADM/ CM	9,300.00	6,105.37	65.65
557.192	ADMIN/OH COVID-19	0.00	587.22	100.00
560.000	COLLECTION & TRANSMISSION	613,100.00	314,054.82	51.22
560.192	COLLECTION & TRANSMISSION - COVID-19	0.00	849.56	100.00
571.000	OM & R-WASTEWATER	719,000.00	538,633.53	74.91
572.000	CAPITAL - WASTEWATER	253,000.00	189,376.47	74.85
TOTAL EXPENDITURES		2,053,000.00	1,304,667.12	63.55
Fund 676 - SEWER UTILITY FUND:				
TOTAL REVENUES		2,053,000.00	1,573,245.20	76.63
TOTAL EXPENDITURES		2,053,000.00	1,304,667.12	63.55
NET OF REVENUES & EXPENDITURES		0.00	268,578.08	100.00

04/20/2021 12:55 PM
 User: PAUL
 DB: Ironwood

REVENUE AND EXPENDITURE REPORT FOR CITY OF IRONWOOD
 PERIOD ENDING 03/31/2021
 % Fiscal Year Completed: 75.07

GL NUMBER	DESCRIPTION	2020-21 AMENDED BUDGET	YTD BALANCE		% BDGT USED
			NORMAL	03/31/2021 (ABNORMAL)	
Fund 711 - CEMETERY FUND					
Revenues					
711-000.000-626.000	CHARGES FOR CEMETERY SERVICES	38,000.00		37,810.00	99.50
711-000.000-627.000	CHARGES CEM PERPETUAL CARE	4,000.00		3,025.00	75.63
711-000.000-664.000	INTEREST AND DIVIDENDS	6,000.00		102.67	1.71
711-000.000-675.000	CONTRIBUTIONS AND DONATION	0.00		2,500.00	100.00
711-000.000-688.000	TRANSFER FROM GENERAL FUND	52,000.00		19,819.31	38.11
TOTAL REVENUES		100,000.00		63,256.98	63.26
Expenditures					
276.000	CEMETERY	74,500.00		49,787.30	66.83
276.192	CEMETERY COVID-19	0.00		723.43	100.00
277.000	PERPETUAL CARE	25,500.00		12,746.25	49.99
TOTAL EXPENDITURES		100,000.00		63,256.98	63.26
Fund 711 - CEMETERY FUND:					
TOTAL REVENUES		100,000.00		63,256.98	63.26
TOTAL EXPENDITURES		100,000.00		63,256.98	63.26
NET OF REVENUES & EXPENDITURES		0.00		0.00	0.00

04/20/2021 12:55 PM
 User: PAUL
 DB: Ironwood

REVENUE AND EXPENDITURE REPORT FOR CITY OF IRONWOOD
 PERIOD ENDING 03/31/2021
 % Fiscal Year Completed: 75.07

GL NUMBER	DESCRIPTION	2020-21 AMENDED BUDGET	YTD BALANCE		% BGD USED
			NORMAL	03/31/2021 (ABNORMAL)	
Fund 899 - DOWNTOWN DEVELOPMENT AUTHORITY					
Revenues					
899-000.000-403.000	CURRENT PROPERTY TAXES	12,000.00		9,000.00	75.00
899-000.000-534.000	GRANTS - OTHER	5,000.00		4,000.00	80.00
899-000.000-675.000	CONTRIBUTIONS AND DONATION	3,000.00		1,298.00	43.27
899-000.000-692.000	MISCELLANEOUS INCOME	1,000.00		1,167.00	116.70
TOTAL REVENUES		21,000.00		15,465.00	73.64
Expenditures					
735.000	DOWNTOWN DEVELOPMENT	21,000.00		9,928.18	47.28
TOTAL EXPENDITURES		21,000.00		9,928.18	47.28
Fund 899 - DOWNTOWN DEVELOPMENT AUTHORITY:					
TOTAL REVENUES		21,000.00		15,465.00	73.64
TOTAL EXPENDITURES		21,000.00		9,928.18	47.28
NET OF REVENUES & EXPENDITURES		0.00		5,536.82	100.00

CASH SUMMARY BY ACCOUNT FOR CITY OF IRONWOOD
 FROM 03/01/2021 TO 03/31/2021
 FUND: ALL FUNDS
 CASH AND INVESTMENT ACCOUNTS

Fund Account	Description	Beginning Balance 03/01/2021	Total Debits	Total Credits	Ending Balance 03/31/2021
Fund 101	GENERAL FUND				
002.000	CASH IN BANK	5,158,856.85	630,819.38	210,422.60	5,579,253.63
002.005	FIRE INSURANCE TRUST	20,875.90	8.84	0.00	20,884.74
014.000	INVESTMENTS - MI CLASS	284.93	0.00	0.00	284.93
	GENERAL FUND	<u>5,180,017.68</u>	<u>630,828.22</u>	<u>210,422.60</u>	<u>5,600,423.30</u>
Fund 203	LOCAL STREET FUND				
006.023	2012 Street Bond Debt Service	1,826.85	0.77	0.00	1,827.62
Fund 216	VOLUNTEER FIRE DEPARTMENT				
002.000	CASH IN BANK	3,419.57	0.00	0.00	3,419.57
Fund 271	LIBRARY FUND				
002.000	CASH IN BANK	146,670.67	1,541.45	12,752.13	135,459.99
002.271	CASH - ANNUAL APPEAL	78,000.00	0.00	0.00	78,000.00
002.272	CASH - BUILDING FUND	42,000.00	0.00	0.00	42,000.00
014.271	INVESTMENTS - MI CLASS - ANNUAL	696.79	0.00	0.00	696.79
014.272	INVESTMENTS - MI CLASS - BUILDING	883.57	0.00	0.00	883.57
	LIBRARY FUND	<u>268,251.03</u>	<u>1,541.45</u>	<u>12,752.13</u>	<u>257,040.35</u>
Fund 273	NEIGHBORHOOD ENHANCEMENT PROGRAM				
002.000	CASH IN BANK	5,230.00	0.00	30.00	5,200.00
Fund 274	HUD FUND				
002.000	CASH IN BANK	320,000.00	0.00	0.00	320,000.00
Fund 352	2015 STREET BOND DEBT SERVICE FUND				
002.000	CASH IN BANK	52,332.81	2,069.34	13.87	54,388.28
Fund 401	MEMORIAL BUILDING DEBT SERVICE FUND				
002.000	CASH IN BANK	4,234.71	1.79	0.00	4,236.50
Fund 593	CIVIC CENTER				
002.000	CASH IN BANK	124,577.11	1,123.37	19,932.77	105,767.71
006.025	2013 CAP IMP BOND DEBT SERVIC	12,944.04	4.47	2,562.09	10,386.42
	CIVIC CENTER	<u>137,521.15</u>	<u>1,127.84</u>	<u>22,494.86</u>	<u>116,154.13</u>
Fund 640	EQUIPMENT FUND				
014.000	INVESTMENTS - MI CLASS	459.33	0.00	0.00	459.33
Fund 675	WATER UTILITY FUND				
002.000	CASH IN BANK	1,174,515.84	196,670.10	149,536.37	1,221,649.57
002.001	REPAIR, REPLACE, IMPROVE CASH	303,217.13	0.00	0.00	303,217.13
006.015	WATER REDEMPTION (1,2,3,4)	224,491.97	95.33	0.00	224,587.30
006.016	WATER RESERVE (1,2,3,4)	229,070.55	97.31	0.00	229,167.86
014.000	INVESTMENTS - MI CLASS	945.97	0.00	0.00	945.97
	WATER UTILITY FUND	<u>1,932,241.46</u>	<u>196,862.74</u>	<u>149,536.37</u>	<u>1,979,567.83</u>
Fund 676	SEWER UTILITY FUND				
002.000	CASH IN BANK	1,785,700.09	199,551.01	126,228.22	1,859,022.88
002.001	REPAIR, REPLACE, IMPROVE CASH	71,167.13	0.00	0.00	71,167.13
006.018	SEWER REDEMPTION (1,2,3,4)	131,359.67	55.79	0.00	131,415.46
006.019	SEWER RESERVE (1,2,3,4)	183,462.58	77.92	0.00	183,540.50
014.000	INVESTMENTS - MI CLASS	575.85	0.00	0.00	575.85
	SEWER UTILITY FUND	<u>2,172,265.32</u>	<u>199,684.72</u>	<u>126,228.22</u>	<u>2,245,721.82</u>
Fund 701	TRUST AND AGENCY FUND				

CASH SUMMARY BY ACCOUNT FOR CITY OF IRONWOOD
 FROM 03/01/2021 TO 03/31/2021
 FUND: ALL FUNDS
 CASH AND INVESTMENT ACCOUNTS

Fund Account	Description	Beginning Balance 03/01/2021	Total Debits	Total Credits	Ending Balance 03/31/2021
002.000	CASH IN BANK	231,019.67	5,612.77	209,424.71	27,207.73
Fund 711	CEMETERY FUND				
002.000	CASH IN BANK	500,000.00	2,040.00	2,040.00	500,000.00
014.000	INVESTMENTS - MI CLASS	265.86	0.00	0.00	265.86
	CEMETERY FUND	<u>500,265.86</u>	<u>2,040.00</u>	<u>2,040.00</u>	<u>500,265.86</u>
Fund 732	POLICE & FIREMEN'S RETIREMENT				
002.000	CASH IN BANK	336,109.83	9,204.24	34,004.86	311,309.21
Fund 733	RETIREE HEALTHCARE FUND				
002.000	CASH IN BANK	8,432.59	10,704.54	9,548.82	9,588.31
002.003	MERS INVESTMENTS	1,934,878.82	74,923.86	10,000.00	1,999,802.68
	RETIREE HEALTHCARE FUND	<u>1,943,311.41</u>	<u>85,628.40</u>	<u>19,548.82</u>	<u>2,009,390.99</u>
Fund 899	DOWNTOWN DEVELOPMENT AUTHORITY				
002.000	CASH IN BANK	29,911.85	0.54	116.67	29,795.72
	TOTAL - ALL FUNDS	<u>13,118,418.53</u>	<u>1,134,602.82</u>	<u>786,613.11</u>	<u>13,466,408.24</u>

Check Date	Check	Vendor Name	Description	Amount
Bank RIVER RIVER VALL				
03/01/2021	142638	POSTMASTER - IRONWOOD	POSTAGE	95.52
			POSTAGE	95.52
				<u>191.04</u>
03/04/2021	142639	POSTMASTER - IRONWOOD	POSTAGE	68.58
			POSTAGE	68.58
				<u>137.16</u>
03/04/2021	142640	1STAYD CORP	ORANGE NITRILE GLOVES-DPW	60.72
03/04/2021	142641	AIRGAS USA, LLC	COMPRESSED GAS CD/AR - DPW	134.29
03/04/2021	142642	AUTOMATED BUSINESS EQUIPMENT	SERV CONTRACT FOLDING/STUFFING MACHINE	900.00
03/04/2021	142643	BAKER & TAYLOR BOOKS INC	BOOKS LIBRARY	187.96
			BOOKS LIBRARY	206.56
				<u>394.52</u>
03/04/2021	142644	CENGAGE LEARNING, INC/GALE	BOOKS LIBRARY	24.79
03/04/2021	142645	CHARTER COMMUNICATIONS	PHONE & INTERNET - MEM BLDG	407.08
03/04/2021	142646	CHIEF OIL CO	HEATING FUEL 144 GALS @\$2.40-CEMETERY	345.60
03/04/2021	142647	COMPUTER DOCTORS	10 - MICROSOFT WINDOWS - PSD	1,320.00
			MONTHLY ONLINE BACKUP CHARGES	2,608.54
			COMPUTER SERVICES	22.50
			COMPUTER SERVICES	90.00
				<u>4,041.04</u>
03/04/2021	142648	DAILY GLOBE	NEP HOUSING REHAB 110 W NORRIE	85.15
			NEP HOUSING REHAB 414 ALBANY	85.15
			PROGRESS-EDUCATION - LIBRARY	106.00
			PUBLIC NOTICES	325.00
			PAVEMENT MARKING BIDS	85.15
			CITY ENTRANCE SIGNS BID	85.15
			MARIJUANA AMENDMENTS MTG	85.15
			SITE PLAN THREE TWINS-MARIJUANA ESTB	85.15
			CONDITIONAL USE THREE TWINS	85.15
			MINE SHAFT SAFETY FENCING BID	116.20
			PLAYGROUND IMPROVEMENT BID	116.20
				<u>1,259.45</u>
03/04/2021	142649	ECONO SIGNS	NO PARKING, STOP SPEED, DEAD END&STREET SI	4,579.95
03/04/2021	142650	GIOVANOINI TRUE VALUE HDWR	2 - CLIP LIGHTS - WATER DEPT	10.78
03/04/2021	142651	GOGEBIC COUNTY TREASURER	CHARGEBACKS-BROWNFIELD CAPTURE	191.84
03/04/2021	142652	INCREDIBLE BANK-CREDIT CARD	CREDIT CARD PAYMENT	2,581.35
03/04/2021	142653	IRONWOOD WATER & SEWER UTIL	AURE-235-01	70.16
			MARS-213-01	1,176.92
			MCLW-123-01	1,123.08
				<u>2,370.16</u>
03/04/2021	142654	IRONWOOD-HURLEY ROTARY CLUB	MEALS & DUES - S ERICKSON	59.00
03/04/2021	142655	JACK DOHENY SUPPLIES INC	PARTS ROLLER & RING-VACTOR	739.10
			HANDLE - VACTOR	283.04

Check Date	Check	Vendor Name	Description	Amount
03/10/2021	142679	CHARTER COMMUNICATIONS	PHONE - LIBRARY 200 PENOKEE - DPW E4932 SPRING CREEK RD	97.02 271.53 342.74 <u>711.29</u>
03/10/2021	142680	COMPUTER DOCTORS	MAINT GIS SERVER COMPUTER SERVICE	95.50 71.25 <u>166.75</u>
03/10/2021	142681	DEAN LAW OFFICE, P.C.	LEGAL SERVICES - FEB 2021	1,138.50
03/10/2021	142682	GALLS, LLC	3-SWITCH MODULE - PSD UNIFORM - PSD UNIFORM - PSD UNIFORM - PSD UNIFORM - PSD UNIFORM - PSD	56.85 214.24 12.83 333.86 59.50 70.81 <u>748.09</u>
03/10/2021	142683	GIOVANONI TRUE VALUE HDWR	FIX HOT WTR LINES MEN'S BATHROOM-PSD FIX LEAK ON BOILER - PSD	384.85 136.27 <u>521.12</u>
03/10/2021	142684	GOGEBIC-IRON WASTEWATER AUTH	WASTEWATER TREATMENT-MAR	80,890.00
03/10/2021	142685	IRON COUNTY MINER	BUSINESS CARDS - J ALONEN	39.00
03/10/2021	142686	IRONWOOD WATER & SEWER UTIL	CLEM-205-01	144.72
03/10/2021	142687	JOHN DEERE FINANCIAL	PAINTING SUPPLIES - CIVIC CTR	142.02
03/10/2021	142688	KENNETH ZUPAN	MAILBOX DAMAGE	30.00
03/10/2021	142689	LAYMAN, RON	UB refund for account: TAMW-000138-0000-	235.28
03/10/2021	142690	MICHELLE MARIE RIGONI-SIVULA	CUSTODIAL SERVICES - MEM BLDG CUSTODIAL SERVICES - MEM BLDG CUSTODIAL SERVICES - MEM BLDG	235.80 235.80 235.80 <u>707.40</u>
03/10/2021	142691	MICHIGAN STATE UNIVERSITY	BOOK - LIBRARY	100.00
03/10/2021	142692	NORTH AMERICAN, INC.	NEW OVERHEAD DOOR - PSD	4,826.00
03/10/2021	142693	NORTHERN MI ASSOC CHIEFS OF POLICE	DUES NOTICE - A. DIGIORGIO	75.00
03/10/2021	142694	POLICH, GREG	UB refund for account: AURE-000137-0000-	373.74
03/10/2021	142695	QUILL CORP	CUSTODIAL SUPPLIES - PSD OFFICE SUPPLIES - PSD CUSTODIAL SUPPLIES - PSD CUSTODIAL SUPPLIES - PSD BROOM - OFFICE SUPPLIES - PSD OFFICE SUPPLIES - PSD	33.73 15.99 19.29 40.03 5.99 107.24 <u>222.27</u>
03/10/2021	142696	RANGE CORP	MISS DIG - MARCH 2021	48.20
03/10/2021	142697	STATE OF MICHIGAN-MI ST POLICE	SOR - PSD SOR - PSD	90.00 30.00 <u>120.00</u>
03/10/2021	142698	STEELE, ROBERT	UB refund for account: AYER-000300-0000-	293.46

CHECK REGISTER FOR CITY OF IRONWOOD
 CHECK DATE FROM 03/01/2021 - 03/31/2021

Check Date	Check	Vendor Name	Description	Amount
03/10/2021	142699	SUPERIOR RANGE SHOOTERS CLUB, INC	ANNUAL CORP MEMBERSHIP-PSD	500.00
03/10/2021	142700	TRI-STATE BUSINESS SYSTEMS INC	TONER CONTRACT - PSD	147.74
03/10/2021	142701	U P ASSESSORS ASSOCIATION	DUES - J ALONEN R-9569	15.00
03/10/2021	142702	U P REGION OF LIBRARY	ANNUAL SUBSCRIPTION RENEWAL-LIBRARY	174.28
03/10/2021	142703	VANDENBURG PROPERTIES	UB refund for account: LOWN-000101-0000-	1,345.45
03/10/2021	142704	WIECHMAN, ROBERT	UB refund for account: DOUG-000430-0000-	269.68
03/10/2021	142705	XCEL ENERGY	STREET LIGHTS	6,464.49
			GROUP POWER BILL	9,122.72
				<u>15,587.21</u>
03/16/2021	142706	POSTMASTER - IRONWOOD	POSTAGE - CYCLE B - WATER PORTION	88.02
			POSTAGE - CYCLE B - SEWER PORTION	88.02
				<u>176.04</u>
03/17/2021	142707	GOGEBIC CO REGISTER OF DEEDS	REGISTER MSHDA MORTGAGE-101 W. NORRIE ST	30.00
03/23/2021	142708	POSTMASTER - IRONWOOD	POSTAGE	92.88
			POSTAGE	92.88
				<u>185.76</u>
03/26/2021	142709	44 NORTH	HRA, FSA & COBRA BUNDLED FEES-MAR	1,012.00
03/26/2021	142710	ADVANCED DISPOSAL SERVICES	DUMPSTER CHARGES FEB 2021	309.31
03/26/2021	142711	AIRGAS USA, LLC	CYLINER RENTAL	32.27
03/26/2021	142712	ASPIRUS CLINICS, INC	DRUG SCREENING- J ROBERTS	25.00
			DRUG SCREENING- J MONETTE	25.00
				<u>50.00</u>
03/26/2021	142713	AUTO VALUE IRONWOOD	MAINT SUPPLIES - DPW	93.89
			MAINT SUPPLIES - DPW	43.47
				<u>137.36</u>
03/26/2021	142714	AUTOMATED COMFORT CONTROLS, INC	HEATING ISSUES @ MEM BLDG	470.00
03/26/2021	142715	BAKER & TAYLOR BOOKS INC	BOOKS LIBRARY	197.48
			BOOKS LIBRARY	23.63
			BOOKS LIBRARY	221.87
			BOOKS LIBRARY	194.58
				<u>637.56</u>
03/26/2021	142716	BLOOMFIELD TWP PUB. LIBRARY-GF	LOST DVD - LIBRARY	35.00
03/26/2021	142717	BLUE CARE NETWORK OF MICHIGAN	HOSPITALIZATION - APRIL	31,001.99
03/26/2021	142718	BLUE CROSS,BLUE SHIELD OF MI	HOSPITALIZATION - APRIL	3,651.65
03/26/2021	142719	BLUE CROSS,BLUE SHIELD OF MI	HOSPITALIZATION - APRIL	4,003.44
03/26/2021	142720	BLUE CROSS,BLUE SHIELD OF MI	HOSPITALIZATION - APRIL	2,733.10
03/26/2021	142721	BS&A SOFTWARE, INC.	CEMETERY MANAGEMENT PROGRAM	850.00
03/26/2021	142722	C & M OIL CO.	55 GALS DEF - DPW	115.50
03/26/2021	142723	CENGAGE LEARNING, INC/GALE	BOOKS LIBRARY	23.39
			BOOKS LIBRARY	298.87
			BOOKS LIBRARY	11.05
			BOOKS LIBRARY	23.39
				<u>356.70</u>

Check Date	Check	Vendor Name	Description	Amount
03/26/2021	142724	CHARTER COMMUNICATIONS	TV & INTERNET - WATER OFFICE TV, INTERNET & PHONE - C.C.	76.97 297.50 <hr/> 374.47
03/26/2021	142725	COLLABORATIVE SUMMER LIBRARY PRGM	SUMMER PROGRAM SUPPLIES-LIBRARY	110.26
03/26/2021	142726	COMPUTER DOCTORS	COMPUTER SERVICES COMPUTER SERVICES WEBCAM OFFLINE - MT ZION COMPUTER SERVICE DOMAIN HOSTING ANNUAL RENEWAL	295.55 112.50 22.50 22.50 259.00 <hr/> 712.05
03/26/2021	142727	COMPUTER DOCTORS	NEW COMPUTER - CIVIC CTR	789.00
03/26/2021	142728	CORE & MAIN LP	32 - IPERL 5/8" WATER METERS	4,085.00
03/26/2021	142729	CRAMBLIT'S WELDING, LLC	GROUND CLAMP&CABLE SET CONNECTORS #93	351.00
03/26/2021	142730	DELTA DENTAL OF MICHIGAN	DENTAL - APRIL	1,845.16
03/26/2021	142731	DWD ENTERPRISES OF EAU CLAIRE, LLC	HOSE REEL SWIVEL - #92	174.50
03/26/2021	142732	EAGLE WASTE & RECYCLING, INC -	CURBSIDE TRASH & RECYCLING-FEB RECYCLING FEB - LIBRARY RECYCLING FEB - MEM BLDG RECYCLING FEB - PSD	29,213.45 4.32 4.32 4.32 <hr/> 29,226.41
03/26/2021	142733	ETNA SUPPLY	6-FERNCO 8X8 FLEX COUPLINGS-SWR 2-SPLIT COUPLING - SWR 800' -3/4" SOFT COIL COPPER&COUPLINGS	181.80 30.00 4,040.00 <hr/> 4,251.80
03/26/2021	142734	G.T.C. AUTO PARTS INC	ALTERNATOR - #27 MAIN SUPPLIES & PARTS - DPW MAINT SUPPLIES - DPW CORE RETURN - ALTERNATOR #27	145.42 64.37 191.83 (25.00) <hr/> 376.62
03/26/2021	142735	GOGEBIC RANGE SOLID WASTE	REMOVAL OF MATTRESSES-COMPOST SITE	46.50
03/26/2021	142736	HAWKINS, INC	CHLORINE & LPC-AM - PUMP STN	2,338.89
03/26/2021	142737	HIGH PERFORMANCE PRODUCTS	SUPPLIES - DPW	258.20
03/26/2021	142738	HOLIDAY COMPANIES	GAS USAGE	6,182.77
03/26/2021	142739	INTERSTATE POWER SYSTEMS, INC	INSP ENGINE-HEAD GASKET LEAK-PUMP STN REGASKET CYLINDER HEADS - PUMP STN	1,991.26 17,167.99 <hr/> 19,159.25
03/26/2021	142740	IRONWOOD TOWNSHIP	4972 E JACKSON RD - C.C.	176.84
03/26/2021	142741	IRONWOOD WATER & SEWER UTIL	MARS-SEW-01 MARS-SD-01 MARS-PRKS-01 MARS-CEM-01	21.67 13.33 30.00 23.75 <hr/> 88.75
03/26/2021	142742	JOHN DEERE FINANCIAL	TAPE RULE & TRUCK SIDE BOARDS-DPW	163.66
03/26/2021	142743	LAHTI TOWING & SALES, INC	TOW SNOWMOBILE - PSD	40.00

Check Date	Check	Vendor Name	Description	Amount
03/26/2021	142744	MICHIGAN RURAL WATER ASSOC	MATH REVIEW-ONLINE-J FRANKLIN S3 & S4 WTR REVIEW-ONLINE-J FRANKLIN	310.00 310.00 <hr/> 620.00
03/26/2021	142745	MICHIGAN RURAL WATER ASSOC	CORRELATOR MAINT FEE	300.00
03/26/2021	142746	MICRO MARKETING LLC	AUDIO VISUAL - LIBRARY	149.47
03/26/2021	142747	MILLER-BRADFORD & RISBERG, INC	4 - PINS #56 TUBE ASSBLT - #79	40.35 181.05 <hr/> 221.40
03/26/2021	142748	MONROE TRUCK EQUIPMENT, INC	CYLINDER & KIT #68	4,472.46
03/26/2021	142749	MUKAVITZ HEATING	SERVICE NO HEAT GARAGE	105.00
03/26/2021	142750	NELSON, RUTH	UB refund for account: MICE-000124-0000-	295.86
03/26/2021	142751	NORB'S AUTO ELECTRIC	BATTERY #27 FLASHING RED LIGHTS-#73&75 BATTERIES - #85	177.95 361.90 357.90 <hr/> 897.75
03/26/2021	142752	NORTH AMERICAN BENEFITS CO	LIFE INSURANCE - APRIL	205.90
03/26/2021	142753	NORTHWOODS VAC & CLEANING	CUSTODIAL SUPPLIES - MEM BLDG	179.75
03/26/2021	142754	NUNN, JOHN	UB refund for account: FLOR-000818-0000-	318.98
03/26/2021	142755	OREILLY AUTO PARTS	BULBS - SANDER #49	51.56
03/26/2021	142756	PETROCHOICE MIDWEST DIVISION -	15W40 OIL & HYDRAULIC FLUID-DPW	2,053.92
03/26/2021	142757	PETTY CASH	REPLENISH PETTY CASH - OCT REPLENISH PETTY CASH - NOV REPLENISH PETTY CASH - DEC REPLENISH PETTY CASH - JAN 2021 REPLENISH PETTY CASH - FEB 2021	17.98 18.06 50.58 10.54 39.94 <hr/> 137.10
03/26/2021	142758	PORTERFIELD, DAN	UB refund for account: CLOW-000520-0000-	410.43
03/26/2021	142759	QUILL CORP	WIPES & SANITIZER -LIBRARY	57.98
03/26/2021	142760	RAPID GRAFIKS AND SIGNS	AM LEGION REIMBURSE SIGN-DROP BOX	20.00
03/26/2021	142761	SAARI, JASON	UB refund for account: HARE-000141-0000-	812.85
03/26/2021	142762	SCHOONE, IAN AND ERIN	UB refund for account: FLOR-001312-0000-	288.62
03/26/2021	142763	STEIGER'S HOME CENTER	DRILL/IMPACT KIT 20V&RECIP SAW-CEMETERY DRILL/IMPACT KIT 20V&RECIP SAW-CEMETERY	339.98 0.00 <hr/> 339.98
03/26/2021	142764	SUPERIORLAND LIBRARY	2-DELL LAPTOPS- LIBRARY	1,035.08
03/26/2021	142765	SYNCB/AMAZON	36CT 5OZ ICE MELT DEWALT 20V MAX HEAT GUN DEWALT 12V MAX INFRARED THERMO KIT 2 - DEWALT 20V BATTERIES POSTAGE METER TAPES OFFICE SUPPLIES	47.95 164.36 299.98 169.00 18.74 94.55 <hr/> 794.58
03/26/2021	142766	THE BOOK FARM, INC	BOOKS LIBRARY	120.89
03/26/2021	142767	THE NEW YORK TIMES	SUBSCRIPTION - LIBRARY	16.00
03/26/2021	142768	U.S. BANK EQUIPMENT FINANCE	COPIER LEASE-MXC303W-COMM DEV COPIER LEASE MX2640N-LIBRARY	69.13 122.80 <hr/> 192.00

Check Date	Check	Vendor Name	Description	Amount
				191.93
03/26/2021	142769	VERIZON WIRELESS	CELL PHONE CHARGES	884.62
03/26/2021	142770	WEBSTAIRANT STORE	TABLES, CHAIRS&WASTE CONTAINERS-C.C.	14,126.01
03/26/2021	142771	WESTERN UP DIST HEALTH DEPT-GOGEBIC	RENEWAL FOOD SERVICE LIC.-C.C.	242.50
03/26/2021	142772	WHITE WATER ASSOCIATES, INC	WATER SAMPLE TESTING	102.00
			WATER SAMPLE TESTING	17.00
			WATER SAMPLE TESTING	240.00
			WATER SAMPLE TESTING	17.00
			WATER SAMPLE TESTING	68.00
			WATER SAMPLE TESTING	17.00
				<u>461.00</u>
03/26/2021	142773	XCEL ENERGY	E4972 JACKSON RD	24.63
			110 N LOWELL ST UNIT PAVILLON	632.86
			105 W AURORA ST-CITY SQUARE	152.13
			WELL #4 N11493 LAKE RD	21.73
			DWTWN STREET LIGHTS	173.48
			111Z NORRIE PARK RD UNIT PARK	17.42
			5788 OLD COUNTY RD	173.76
			PUMP STN & 3 WELLS	6,966.77
			219 E FREDERICK ST	68.00
				<u>8,230.78</u>
03/29/2021	142774	POSTMASTER - IRONWOOD	POSTAGE	95.81
			POSTAGE	95.81
				<u>191.62</u>

RIVER TOTALS:

Total of 137 Disbursements:

300,420.44

Bank RVTAX RIVER TAX

03/29/2021	9426	CITY OF IRONWOOD-STREET IMPROVEMENT	TAX DISBURSEMENT FEB 10-MAR 3, 2021	2,047.09
03/29/2021	9427	CITY OF IRONWOOD-TAXES	TAX DISBURSEMENT FEB 10-MAR 3, 2021	31,242.11
03/29/2021	9428	VOID		0.00
03/29/2021	9429	CRAIG MICHAELS	2020 Win Tax Refund 52-22-132-060	46.77
03/29/2021	9430	GOGEBIC COUNTY TREAS -ST EDUC.	TAX DISBURSEMENT FEB 10-MAR 3, 2021	6,043.72
03/29/2021	9431	GOGEBIC COUNTY TREAS-SUMMER TX	TAX DISBURSEMENT FEB 10-MAR 3, 2021	6,804.11
03/29/2021	9432	GOGEBIC COUNTY TREAS-SUMMER TX	LANDBANK FEB 10-MAR 3, 2021	11.23
03/29/2021	9433	GOGEBIC COUNTY TREAS-WINTER TX	TAX DISBURSEMENT FEB 10-MAR 3, 2021	144,608.28
03/29/2021	9434	VOID		0.00
03/29/2021	9435	GOGEBIC-ONT INTERMEDIATE - TAX	TAX DISBURSEMENT FEB 10-MAR 3, 2021	3,695.22
03/29/2021	9436	IRONWOOD AREA SCHOOLS-CONST 01	TAX DISBURSEMENT FEB 10-MAR 3, 2021	787.91
03/29/2021	9437	IRONWOOD AREA SCHOOLS-CONST 09	TAX DISBURSEMENT FEB 10-MAR 3, 2021	511.56
03/29/2021	9438	IRONWOOD AREA SCHOOLS-CONST 10	TAX DISBURSEMENT FEB 10-MAR 3, 2021	2,241.48
03/29/2021	9439	IRONWOOD AREA SCHOOLS-CONST 19	TAX DISBURSEMENT FEB 10-MAR 3, 2021	910.78
03/29/2021	9440	IRONWOOD AREA SCHOOLS-TAX	TAX DISBURSEMENT FEB 10-MAR 3, 2021	10,387.86
03/29/2021	9441	MORRIS, KENNETH	2020 Win Tax Refund 52-22-108-140	35.37
03/29/2021	9442	STATE OF MICHIGAN - LANDBANK	STATE SCHOOL AID FUND	1.22

RVTAX TOTALS:

Check Date	Check	Vendor Name	Description	Amount
------------	-------	-------------	-------------	--------

(2 Checks Voided)

Total of 15 Disbursements:

209,374.71

REPORT TOTALS:

(2 Checks Voided)

Total of 152 Disbursements:

509,795.15

City of Ironwood
213 S. Marquette St.
Ironwood, MI 49938



IRONWOOD
MICHIGAN | *Find Your North*

Phone: (906) 932-5050
Fax: (906) 932-5745
www.cityofironwood.org

MEMO

To: Mayor Burchell and City Commission

From: Tom Bergman, Community Development Director

Date: April 19, 2021

Meeting Date: April 26, 2021

Re: Show Cause Hearing for Violation of Zoning Ordinance at the NW Corner of Hwy. 2 and Walnut Street, Parcel #52-16-483-080

Background

Mr. Bill Leppala of Tula Toilets, property owner at the NW Corner of Hwy. 2 and Walnut Street, Parcel #52-16-483-080, is in violation of the City of Ironwood, Michigan Zoning Ordinance Section 34-152.- Permitted Uses. All permitted uses (as listed in section 34-152) in the C-3 highway commercial district must be conducted wholly in a permanent, fully enclosed building, except as otherwise stated, except public utility structures not usually so enclosed and all permitted uses shall have plans and specifications submitted in accordance with article IX of this chapter.

Section 34-7(2) sets forth enforcement procedures for violation of the zoning ordinance. The zoning administrator may issue up to two notices of ordinance violation with time allowed for compliance. If the property owner fails to comply following the issuance of two notices, the city commission shall issue a show cause hearing notice for a special hearing by interested parties upon the recommendation of the zoning administrator.

Currently the property owner is storing multiple vehicles, commercial trailers (with pump tanks), and portable toilets. There is no permanent primary structure on the property. The Zoning office has sent two letters notifying the property owner of the violations.

Attached to this memo are the two letters as well as photos of the site.

Recommendation

The staff recommendation is to set a Show Cause Hearing for the next regular City Commission Meeting on May 10, 2021 at 5:25pm.



This Institution is an Equal Opportunity Provider, Employer and Housing Employer/Lender



Photos of Tula Toilets Site (NW Corner of Hwy 2 and Walnut Street) Photos taken March 29, 2021





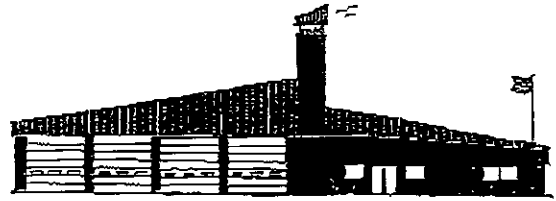
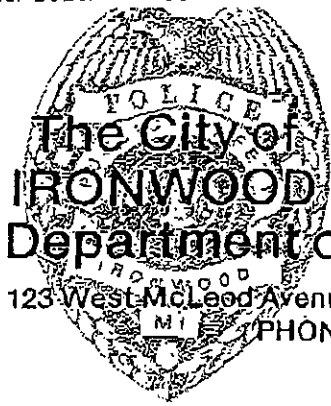

Department of Public Safety
123 West McLeod Avenue Ironwood, Michigan 49938
PHONE: 906-932-1234

Andrew DiGiorgio, Director
Ironwood Public Safety

PAPER SERVICE ATTEMPTS

Complaint No. 21-000312

Date/Time	Defendant's Name / Complete Address of Service	Served / Unexecuted	Badge Number	Officer's Signature
	215 W. Harding Ave Bill Leppala			
1-22-21 2:30PM	LOT ON WALNUT ST.	SERVED	240	

Additional information regarding attempted service:

I have personally attempted to serve the summons and complaint, together with any attachments to the above named defendant and have been unable to complete service.

Date

Public Safety Officer, IPSD



This Institution is an Equal Opportunity Provider, Employer and Housing Employer/Lender



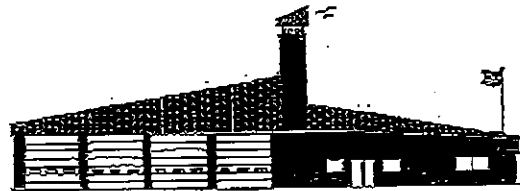
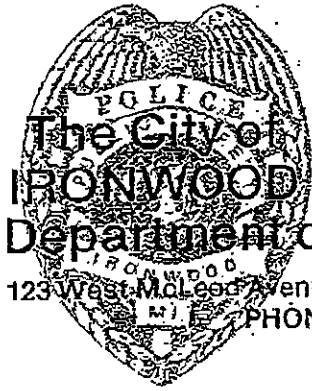

Department of Public Safety

123 West McLeod Avenue Ironwood, Michigan 49938
PHONE: 906-932-1234

RETURN OF SERVICE

COUNTY OF GOGEBIC
STATE OF MICHIGAN

I HEREBY CERTIFY AND RETURN THAT ON 1-22-21, AT Lot on Walnut St.
DATE ADDRESS

IN THE CITY OF IRONWOOD, I SERVED A CERTIFIED COPY OF Paper Service

21-000312

DESCRIPTION OF PAPERWORK

UPON Bill Leppala, KNOWN TO BE THE DEFENDANT NAMED
INDIVIDUAL SERVED

THEREIN, BY THEN AND THERE DELIVERING TO SAID DEFENDANT A CERTIFIED COPY OF THE

Paper Service 21-000312

DESCRIPTION OF PAPERWORK

IN THIS ACTION.

DATE AND TIME: 1-22-21 / 2:30pm

SIGNED: RSO Rinkus
PUBLIC SAFETY OFFICER
IRONWOOD PUBLIC SAFETY
IRONWOOD, MICHIGAN
COUNTY OF GOGEBIC

City of Ironwood
213 S. Marquette St.
Ironwood, MI 49938



IRONWOOD

MICHIGAN | *Find Your North*

Phone: (906) 932-5050
Fax: (906) 932-5745
www.cityofironwood.org

Date: January 15, 2021

TO: Tula Toilets
Bill Leppala
215 W Harding Ave.
Ironwood, MI 49938

RE: Violation of City of Ironwood Zoning Ordinance at the corner of the NW of Hwy. 2 and Walnut Street, Parcel # 52-16-483-080

Mr. Bill Leppala

This letter is to inform you that you are in violation of the City of Ironwood, Michigan Zoning Ordinance Section 34-152.- Permitted Uses. All permitted uses (as listed in section 34-152) in the C-3 highway commercial district must be conducted wholly in a permanent, fully enclosed building, except as otherwise stated, except public utility structures not usually so enclosed and all permitted uses shall have plans and specifications submitted in accordance with article IX of this chapter. Please cease the storage of commercial vehicles, trailers, and portable toilets on the premises within 14 days of the date of this letter or there will be further prosecution of the violation.

For information on this section of the ordinance please go to the following web address:

https://library.municode.com/mi/ironwood/codes/code_of_ordinances?nodeId=PTIICOOR_CH34ZO_ARTIIDI_DIV8HICODI_S34-152PEUS

If you have any questions, please contact the Ironwood Community Development Office at 906-932-5050 ext. 126.

Sincerely,

Tom Bergman
City of Ironwood
Community Development Director/Zoning Administrator



This Institution is an Equal Opportunity Provider, Employer and Housing Employer/Lender



City of Ironwood
213 S. Marquette St.
Ironwood, MI 49938



Phone: (906) 932-5050
Fax: (906) 932-5745
www.cityofironwood.org

Date: February 11, 2021

TO: Tula Toilets
Bill Leppala
215 W Harding Ave.
Ironwood, MI 49938

RE: Second Notice: Violation of City of Ironwood Zoning Ordinance at the corner of the NW of Hwy. 2 and Walnut Street, Parcel # 52-16-483-080

Mr. Bill Leppala

This is the second notice to inform you that you are in violation of the City of Ironwood, Michigan Zoning Ordinance Section 34-152.- Permitted Uses. All permitted uses (as listed in section 34-152) in the C-3 highway commercial district must be conducted wholly in a permanent, fully enclosed building, except as otherwise stated, except public utility structures not usually so enclosed and all permitted uses shall have plans and specifications submitted in accordance with article IX of this chapter. Please cease the storage of commercial vehicles, trailers, and portable toilets on the premises within 14 days from receiving this letter or there will be further prosecution of the violation.

For information on this section of the ordinance please go to the following web address:

https://library.municode.com/mi/ironwood/codes/code_of_ordinances?nodeId=PTIICOOR_CH34ZO_ARTIIDI_DIV8HICODI_S34-152PEUS

If you have any questions, please contact the Ironwood Community Development Office at 906-932-5050 ext. 126.

Sincerely,

Tom Bergman
City of Ironwood
Community Development Director/Zoning Administrator



This Institution is an Equal Opportunity Provider, Employer and Housing Employer/Lender



City of Ironwood
213 S. Marquette St.
Ironwood, MI 49938



Phone: (906) 932-5050
Fax: (906) 932-5745
www.cityofironwood.org

April 20, 2021

MEMO

TO: Scott Erickson, Ironwood City Commission
FROM: Bob Richards, DPW Supervisor
RE: Discuss & Consider Approval of Repair Cost to DPW Backhoe #85 (430D)

The City DPW Vehicle Maintenance Department contacted the Fabick Cat repair shop in Negaunee, Michigan (our closest Cat repair shop) for brakes and caliper replacement for Backhoe #85.

Fabick Cat quoted \$6,040.58 for the initial repair work. During disassembly of the brakes and rear-end housing, Fabick Cat discovered significant deterioration and damage to bearings, gaskets, vee belt, pins and more. The additional cost of this work brought the final repair cost to \$12,365.61.

The additional repairs were necessary to avoid future repairs to the items listed by Fabick Cat. After the work was completed the final bill was \$12,365.61.

It is recommended to approve the repair cost to Backhoe #85 in the amount of \$12,365.61 as completed by Fabick Cat. The funding will be from the Equipment Fund.

Included in your packet is a broken-down description of repairs, parts and labor by Fabick Cat.



Robert Richards
DPW Supervisor

4-21-21
Date



This Institution is an Equal Opportunity Provider, Employer and Housing Employer/Lender





JFTCO Inc.
335 Hwy 41
Negaunee, MI 49866
Phone: 906-475-4191

SERVICE INVOICE

For Invoice questions please call: 636-343-5900 ext. 2970	
Invoice Number	SIMQ0009866
Invoice Date	03-31-21
AMOUNT DUE	CONT'D
Credit Amount	
Customer Order Number	36811
Customer Number	1263612

SOLD TO:

102 2 SP 0.710 E0102X 10769 D7414856098 S2 P8152664 0001:0009



CITY OF IRONWOOD
200 PENOKEE RD
IRONWOOD MI 49938-3166

Please follow Remittance Advice in the detachable section.

SHIP TO:
Marquette
US Highway 41, and Brebner Rd

NEGAUNEE, MI
49866 N71US

PSOWO NUMBER	PC	LC	MC	SHIP VIA	DOC DATE	INV. SEQ. NUMBER	SALESMAN	TERMS	STORE
MQ04778	10	10	10	WILL CALL	03-10-21	7244339	HSE	2	38
MAKE	MODEL	SERIAL NUMBER		EQUIPMENT NUMBER	METER READING	MACH. I.D. NUMBER		DIV	
AA	430D ST	0BNK06820			6504.0	039227		G	
QUANTITY	ITEM	N/R*	DESCRIPTION		UNIT PRICE	EXTENSION			

INSPECT MACHINE

PRIOR TO BEGINNING YOUR SCHEDULED REPAIRS, A TRAINED FABICK CAT TECHNICIAN PERFORMED A THOROUGH OPERATIONAL AND VISUAL INSPECTION ON YOUR MACHINE. SCHEDULED OIL SAMPLE (SOS) HISTORY WAS REVIEWED AND ADDITIONAL OIL SAMPLES WERE TAKEN AS REQUIRED. THIS INSPECTION (A \$75.00 VALUE) WAS PERFORMED AT NO CHARGE TO YOU. UPON COMPLETION OF ALL APPROVED WORK, A FINAL QUALITY CHECK WAS CONDUCTED TO ENSURE YOUR REPAIR WAS COMPLETED AS REQUESTED.

SEGMENT 01 TOTAL .00 T

CLEAN MACHINE

TOTAL LABOR SEG. 02 258.00 *

SEGMENT 02 TOTAL 258.00 T

REMOVE & INSTALL AXLE

ACCEPTANCE - ALL ITEMS LISTED ABOVE WILL BE DEEMED ACCEPTED BY THE CUSTOMER UNLESS WRITTEN NOTIFICATION OF CLAIMED ERRORS OR DAMAGES IS MADE TO DEALER WITHIN 5 DAYS. No merchandise can be returned without our prior approval. All returned parts are subject to our Parts Return Policy, a copy of which is available at www.fabickcat.com or upon request. TERMS: NET DUE WITHIN THIRTY (30) DAYS OF DATE OF INVOICE. 1% per month carrying charge on all past due accounts.

*- NOT RETURNABLE
ITEMS NOT SHOWN
ARE BACK ORDERED

PLEASE PAY THIS AMOUNT	CONT'D
AMOUNT CREDITED	

To receive invoices and statements electronically, and/or to pay invoices online, visit Fabickcat.com and click on the ONLINE TOOLS Tab.

PLEASE DETACH AND RETURN WITH REMITTANCE WITHIN THIRTY (30) DAYS OF INVOICE DATE TO JOHN FABICK TRACTOR COMPANY, P.O. BOX 952121, ST. LOUIS, MO 63195-2121



JFTCO Inc.
335 Hwy 41
Negaunee, MI 49866

CITY OF IRONWOOD
200 S PENOKEE RD
IRONWOOD MI 49938-3166

CUSTOMER NUMBER	
1263612	
INVOICE NUMBER	INVOICE DATE
SIMQ0009866	03-31-21
PLEASE PAY THIS AMOUNT	CONT'D
AMOUNT CREDITED	

THANK YOU FOR YOUR BUSINESS!



JFTCO Inc.
335 Hwy 41
Negaunee, MI 49866
Phone: 906-475-4191

SERVICE INVOICE

Page No. 2

SOLD TO:

102 2 SP 0.710 E0102X I0770 D7414856098 S2 P8152664 0002:0009



CITY OF IRONWOOD
200 PENOKEE RD
IRONWOOD MI 49938-3166

For Invoice questions please call: 636-343-5900 ext. 2970	
Invoice Number	SIMQ0009866
Invoice Date	03-31-21
AMOUNT DUE	CONT'D
Credit Amount	
Customer Order Number	36811
Customer Number	1263612

Please follow Remittance Advice in the detachable section.

SHIP TO:
Marquette
US Highway 41, and Brebner Rd

NEGAUNEE, MI
49866 N71US

PSO/WO NUMBER	PC	LC	MC	SHIP VIA	DOC DATE	INV. SEQ. NUMBER	SALESMAN	TERMS	STORE
MQ04778	10	10	10	WILL CALL	03-10-21	7244339	HSE	2	38
MAKE	MODEL	SERIAL NUMBER	EQUIPMENT NUMBER	METER READING	MACH. I.D. NUMBER	DIV.			
AA	430D ST	0BNK06820		6504.0	039227	G			
QUANTITY	ITEM	N/R*	DESCRIPTION	UNIT PRICE	EXTENSION				
TOTAL LABOR				SEG. 03	1806.00 *				
SEGMENT 03 TOTAL					1806.00 T				

REPAIR BRAKE & AXLE									
1	2J-8163		SEAL	S	4.87	4.87			
2	8H-1607		SEAL	N	9.01	18.02			
4	8M-8157		SEAL O RING	S	1.73	6.92			
4	9R-2495		SEAL-O-RING	S	7.91	31.64			
1	9R-2496		SEAL	N	5.78	5.78			
1	9R-2497		SEAL	N	5.60	5.60			
1	9R-2505		SEAL	S	3.91	3.91			
8	9R-9401		DISC	S	35.83	286.64			
4	9R-9409		SEAL	N	11.52	46.08			
4	9R-9410		SEAL	S	9.95	39.80			
2	118-5839		SEAL	N	67.39	134.78			
8	230-4017		BRAKE DISC	S	46.08	368.64			
1	278-0223		HOUSING-BRAK	N	388.27	388.27			
1	278-0224		HOUSING-BRAK	N	440.96	440.96			
TOTAL PARTS				SEG. 04	1781.91 *				
TOTAL LABOR				SEG. 04	2322.00 *				

ACCEPTANCE - ALL ITEMS LISTED ABOVE WILL BE DEEMED ACCEPTED BY THE CUSTOMER UNLESS WRITTEN NOTIFICATION OF CLAIMED ERRORS OR DAMAGES IS MADE TO DEALER WITHIN 5 DAYS. No merchandise can be returned without our prior approval. All returned parts are subject to our Parts Return Policy, a copy of which is available at www.fabickcat.com or upon request. TERMS: NET DUE WITHIN THIRTY (30) DAYS OF DATE OF INVOICE. 1% per month carrying charge on all past due accounts.

*- NOT RETURNABLE
ITEMS NOT SHOWN
ARE BACK ORDERED

PLEASE PAY THIS AMOUNT	CONT'D
AMOUNT CREDITED	

To receive invoices and statements electronically, and/or to pay invoices online, visit Fabickcat.com and click on the ONLINE TOOLS Tab.

PLEASE DETACH AND RETURN WITH REMITTANCE WITHIN THIRTY (30) DAYS OF INVOICE DATE TO JOHN FABICK TRACTOR COMPANY, P.O. BOX 952121, ST. LOUIS, MO 63195-2121



JFTCO Inc.
335 Hwy 41
Negaunee, MI 49866

CITY OF IRONWOOD
200 S PENOKEE RD
IRONWOOD MI 49938-3166

CUSTOMER NUMBER	
1263612	
INVOICE NUMBER	INVOICE DATE
SIMQ0009866	03-31-21
PLEASE PAY THIS AMOUNT	CONT'D
AMOUNT CREDITED	

THANK YOU FOR YOUR BUSINESS!



JFTCO Inc.
335 Hwy 41
Negaunee, MI 49866
Phone: 906-475-4191

SERVICE INVOICE

For Invoice questions please call: 636-343-5900 ext. 2970	
Invoice Number	SIMQ0009866
Invoice Date	03-31-21
AMOUNT DUE	CONT'D
Credit Amount	
Customer Order Number	36811
Customer Number	1263612

Please follow Remittance Advice in the detachable section.

SOLD TO:

102 2 SP 0.710 E0102X I0771 D7414856098 S2 P8152664 0003:0009



CITY OF IRONWOOD
200 PENOKEE RD
IRONWOOD MI 49938-3166

SHIP TO:
Marquette
US Highway 41, and Brebner Rd

NEGAUNEE, MI
49866 N71US

PSO/WO NUMBER	PC	LC	MC	SHIP VIA	DOC DATE	INV. SEQ. NUMBER	SALESMAN	TERMS	STORE
MQ04778	10	10	10	WILL CALL	03-10-21	7244339	HSE	2	38
MAKE	MODEL	SERIAL NUMBER	EQUIPMENT NUMBER	METER READING	MACH. I.D. NUMBER	DIV.			
AA	430D ST	0BNK06820		6504.0	039227	G			
QUANTITY	ITEM	N/R*	DESCRIPTION	UNIT PRICE	EXTENSION				
1.00			INBOUND FREIGHT		12.25				
			TOTAL MISC CHGS	SEG. 04	12.25 *				
			SEGMENT 04 TOTAL		4116.16 T				

REBEARING& RESEAL AXLE									
COMPLAINT:SMALL COOLANT LEAK CAUSE:BAD GASKET ON FRONT COVER CORRECTION:REPLACE GASKET REPLACED BELTS WHILE I WAS THERE. BELTS HAD BAD WEAR AND PIECES MISSING CONTINGENT DAMAGE:NONE COMPLICATION:NONE LABOR CODE BREAKDOWN: 035-DIAGNOSIS/TROUBLESHOOTING: 010-REMOVE & INSTALL: 017-DISASSEMBLE & ASSEMBLE: 023-SALVAGE/REPAIR: 030-TEST AFTER REPAIR: 001-COMPLICATIONS: COMPLAINT:SOFT PEDAL CAUSE:WORN BRAKE DISCS CORRECTION:REPLACED BRAKE DISCS AND BEARINGS, SEALS THAT WERE BAD.									

ACCEPTANCE - ALL ITEMS LISTED ABOVE WILL BE DEEMED ACCEPTED BY THE CUSTOMER UNLESS WRITTEN NOTIFICATION OF CLAIMED ERRORS OR DAMAGES IS MADE TO DEALER WITHIN 5 DAYS. No merchandise can be returned without our prior approval. All returned parts are subject to our Parts Return Policy, a copy of which is available at www.fabickcat.com or upon request. TERMS: NET DUE WITHIN THIRTY (30) DAYS OF DATE OF INVOICE. 1% per month carrying charge on all past due accounts.

*- NOT RETURNABLE
ITEMS NOT SHOWN
ARE BACK ORDERED

PLEASE PAY THIS AMOUNT	CONT'D
AMOUNT CREDITED	

To receive invoices and statements electronically, and/or to pay invoices online, visit Fabickcat.com and click on the ONLINE TOOLS Tab.

PLEASE DETACH AND RETURN WITH REMITTANCE WITHIN THIRTY (30) DAYS OF INVOICE DATE TO JOHN FABICK TRACTOR COMPANY, P.O. BOX 952121, ST. LOUIS, MO 63195-2121



JFTCO Inc.
335 Hwy 41
Negaunee, MI 49866

CITY OF IRONWOOD
200 S PENOKEE RD
IRONWOOD MI 49938-3166

CUSTOMER NUMBER	
1263612	
INVOICE NUMBER	INVOICE DATE
SIMQ0009866	03-31-21
PLEASE PAY THIS AMOUNT	CONT'D
AMOUNT CREDITED	

THANK YOU FOR YOUR BUSINESS!



JFTCO Inc.
335 Hwy 41
Negaunee, MI 49866
Phone: 906-475-4191

SERVICE INVOICE

SOLD TO:

102 2 SP 0.710 E0102X I0772 D7414856098 S2 P8152664 0004:0009



CITY OF IRONWOOD
200 PENOKEE RD
IRONWOOD MI 49938-3166

For Invoice questions please call: 636-343-5900 ext. 2970	
Invoice Number	SIMQ0009866
Invoice Date	03-31-21
AMOUNT DUE	CONT'D
Credit Amount	
Customer Order Number	36811
Customer Number	1263612

Please follow Remittance Advice in the detachable section.

SHIP TO:
Marquette
US Highway 41, and Brebner Rd

NEGAUNEE, MI
49866 N71US

PSO/WO NUMBER	PC	LC	MC	SHIP VIA	DOC DATE	INV. SEQ. NUMBER	SALESMAN	TERMS	STORE
MQ04778	10	10	10	WILL CALL	03-10-21	7244339	HSE	2	38
MAKE	MODEL	SERIAL NUMBER	EQUIPMENT NUMBER	METER READING	MACH. I.D. NUMBER	DIV.			
AA	430D ST	0BNK06820		6504.0	039227	G			
QUANTITY	ITEM	N/R*	DESCRIPTION	UNIT PRICE	EXTENSION				
CONTINGENT DAMAGE: BRAKE DISCS WORE INTO BRAKE HOUSING ON BOTH SIDE HAD TO REPLACE COMPLICATION: NONE LABOR CODE BREAKDOWN: 035-DIAGNOSIS/TROUBLESHOOTING: 010-REMOVE & INSTALL: 017-DISASSEMBLE & ASSEMBLE: 023-SALVAGE/REPAIR: 030-TEST AFTER REPAIR: BLEED BRAKES OUT AND ADJUSTED PARKING BRAKE 001-COMPLICATIONS:									
1	2A-4576		CUP	N	27.34	27.34			
1	2L-6267		NUT	N	.61	.61			
12	2M-2570		NUT	N	2.05	24.60			
6	3B-4509		LOCKWASHER	S	.23	1.38			
1	3B-5302		COTTER PIN	N	.23	.23			
2	5M-8135		VEE BELT	S	20.76	41.52			
2	6Y-7652		CUP	S	25.25	50.50			
2	7T-6652		CONE	N	45.17	90.34			
2	8S-9151		CUP	N	30.70	61.40			
2	9R-0431		BEARING	S	25.30	50.60			
1	9R-2426		LOCK	N	44.23	44.23			
2	9R-2435		SPACER	N	2.20	4.40			
1	9R-2437		SPACER	N	2.89	2.89			
1	9R-2441		SPACER	N	2.09	2.09			
1	9R-2486		SPRING	N	48.05	48.05			
4	9R-2489		WASHER	N	12.69	50.76			
1	9R-2490		WASHER	N	24.32	24.32			
1	9R-2491		SPIDER	N	421.85	421.85			

ACCEPTANCE - ALL ITEMS LISTED ABOVE WILL BE DEEMED ACCEPTED BY THE CUSTOMER UNLESS WRITTEN NOTIFICATION OF CLAIMED ERRORS OR DAMAGES IS MADE TO DEALER WITHIN 5 DAYS. No merchandise can be returned without our prior approval. All returned parts are subject to our Parts Return Policy, a copy of which is available at www.fabickcat.com or upon request. TERMS: NET DUE WITHIN THIRTY (30) DAYS OF DATE OF INVOICE. 1% per month carrying charge on all past due accounts.

* - NOT RETURNABLE
ITEMS NOT SHOWN
ARE BACK ORDERED

PLEASE PAY THIS AMOUNT	CONT'D
AMOUNT CREDITED	

To receive invoices and statements electronically, and/or to pay invoices online, visit Fabickcat.com and click on the ONLINE TOOLS Tab.

PLEASE DETACH AND RETURN WITH REMITTANCE WITHIN THIRTY (30) DAYS OF INVOICE DATE TO JOHN FABICK TRACTOR COMPANY, P.O. BOX 952121, ST. LOUIS, MO 63195-2121



JFTCO Inc.
335 Hwy 41
Negaunee, MI 49866

CITY OF IRONWOOD
200 S PENOKEE RD
IRONWOOD MI 49938-3166

CUSTOMER NUMBER	
1263612	
INVOICE NUMBER	INVOICE DATE
SIMQ0009866	03-31-21
PLEASE PAY THIS AMOUNT	CONT'D
AMOUNT CREDITED	

THANK YOU FOR YOUR BUSINESS!



JFTCO Inc.
335 Hwy 41
Negaunee, MI 49866
Phone: 906-475-4191

SERVICE INVOICE

SOLD TO:

102 2 SP 0.710 E0102X I0773 D7414856098 S2 P8152664 0005:0009



CITY OF IRONWOOD
200 PENOKEE RD
IRONWOOD MI 49938-3166

For Invoice questions please call: 636-343-5900 ext. 2970	
Invoice Number	SIMQ0009866
Invoice Date	03-31-21
AMOUNT DUE	CONT'D
Credit Amount	
Customer Order Number	36811
Customer Number	1263612

Please follow Remittance Advice in the detachable section.

SHIP TO:
Marquette
US Highway 41, and Brebner Rd

NEGAUNEE, MI
49866 N71US

PSO/WO NUMBER	PC	LC	MC	SHIP VIA	DOC DATE	INV. SEQ. NUMBER	SALESMAN	TERMS	STORE
MQ04778	10	10	10	WILL CALL	03-10-21	7244339	HSE	2	38
MAKE	MODEL	SERIAL NUMBER	EQUIPMENT NUMBER	METER READING	MACH. I.D. NUMBER	DIV.			
AA	430D ST	0BNK06820		6504.0	039227	G			
QUANTITY	ITEM	N/R*	DESCRIPTION	UNIT PRICE	EXTENSION				
1	9R-9403		PINION	N 99.61	99.61				
2	030-1957		CONE BEARING	N 40.22	80.44				
1	225-8019		GASKET-PUMP-	S 25.57	25.57				
1	225-8287		GASKET-COVER	S 72.43	72.43				
3	238-8648		CAT ELC	S 14.00	42.00				
1	288-4212		WIPERS	S 23.56	23.56				
TOTAL PARTS				SEG. 05	1290.72 *				
TOTAL LABOR				SEG. 05	2295.00 *				
4.00	INBOUND FREIGHT				49.00				
TOTAL MISC CHGS				SEG. 05	49.00 *				
SEGMENT 05 TOTAL					3634.72 T				

REMOVE & INSTALL/REPLACE SWING BOOM

COMPLAINT: MOVEMENT IN PIN
CAUSE: WEAR
CORRECTION: REPLACE BUSHING AND PIN
CONTINGENT DAMAGE: NONE
COMPLICATION: PIN FROZE IN HAD TO BE CUT OUT
LABOR CODE BREAKDOWN

ACCEPTANCE - ALL ITEMS LISTED ABOVE WILL BE DEEMED ACCEPTED BY THE CUSTOMER UNLESS WRITTEN NOTIFICATION OF CLAIMED ERRORS OR DAMAGES IS MADE TO DEALER WITHIN 5 DAYS. No merchandise can be returned without our prior approval. All returned parts are subject to our Parts Return Policy, a copy of which is available at www.fabickcat.com or upon request. TERMS: NET DUE WITHIN THIRTY (30) DAYS OF DATE OF INVOICE. 1% per month carrying charge on all past due accounts.

*- NOT RETURNABLE
ITEMS NOT SHOWN
ARE BACK ORDERED

PLEASE PAY THIS AMOUNT	CONT'D
AMOUNT CREDITED	

To receive invoices and statements electronically, and/or to pay invoices online, visit Fabickcat.com and click on the ONLINE TOOLS Tab.

PLEASE DETACH AND RETURN WITH REMITTANCE WITHIN THIRTY (30) DAYS OF INVOICE DATE TO JOHN FABICK TRACTOR COMPANY, P.O. BOX 952121, ST. LOUIS, MO 63195-2121



JFTCO Inc.
335 Hwy 41
Negaunee, MI 49866

CUSTOMER NUMBER	
1263612	
INVOICE NUMBER	INVOICE DATE
SIMQ0009866	03-31-21
PLEASE PAY THIS AMOUNT	CONT'D
AMOUNT CREDITED	

CITY OF IRONWOOD
200 S PENOKEE RD
IRONWOOD MI 49938-3166

THANK YOU FOR YOUR BUSINESS!



JFTCO Inc.
335 Hwy 41
Negaunee, MI 49866
Phone: 906-475-4191

SERVICE INVOICE

For Invoice questions please call: 636-343-5900 ext. 2970	
Invoice Number	SIMQ0009866
Invoice Date	03-31-21
AMOUNT DUE	CONT'D
Credit Amount	
Customer Order Number	36811
Customer Number	1263612

Please follow Remittance Advice in the detachable section.

SOLD TO:

102 2 SP 0.710 E0102X I0774 D7414856098 S2 P8152664 0006:0009



CITY OF IRONWOOD
200 PENOKEE RD
IRONWOOD MI 49938-3166

SHIP TO:
Marquette
US Highway 41, and Brebner Rd

**NEGAUNEE, MI
49866 N71US**

PSO/WO NUMBER	PC	LC	MC	SHIP VIA	DOC DATE	INV. SEQ. NUMBER	SALESMAN	TERMS	STORE
MQ04778	10	10	10	WILL CALL	03-10-21	7244339	HSE	2	38
MAKE	MODEL	SERIAL NUMBER	EQUIPMENT NUMBER	METER READING	MACH. I.D. NUMBER	DIV.			
AA	430D ST	0BNK06820		6504.0	039227	G			
QUANTITY	ITEM	N/R*	DESCRIPTION	UNIT PRICE	EXTENSION				
1	3B-8489		FITTING	1.77	1.77				
1	8T-3652		NUT	13.00	13.00				
1	9R-8291		SPACER	11.96	11.96				
1	102-4560		BEARING	43.93	43.93				
1	159-0960		PIN AS	154.35	154.35				
1	176-0626		WASHER	8.08	8.08				
1	300-5442		PIN	98.36	98.36				
TOTAL PARTS				SEG. 06	331.45 *				
TOTAL LABOR				SEG. 06	810.00 *				
1.00	INBOUND FREIGHT				12.25				
TOTAL MISC CHGS				SEG. 06	12.25 *				
SEGMENT 06 TOTAL					1153.70 T				

REMOVE & INSTALL/REPLACE STABILIZER

COMPLAINT: MOVMENT IN PIN
CAUSE: WEAR
CORRECTION: REPLACED BUSHINGS AND PIN
CONTINGENT DAMAGE: NONE
COMPLICATION: FROZEN PIN HAD TO CUT OUT

ACCEPTANCE - ALL ITEMS LISTED ABOVE WILL BE DEEMED ACCEPTED BY THE CUSTOMER UNLESS WRITTEN NOTIFICATION OF CLAIMED ERRORS OR DAMAGES IS MADE TO DEALER WITHIN 5 DAYS. No merchandise can be returned without our prior approval. All returned parts are subject to our Parts Return Policy, a copy of which is available at www.fabickcat.com or upon request. TERMS: NET DUE WITHIN THIRTY (30) DAYS OF DATE OF INVOICE. 1% per month carrying charge on all past due accounts.

* - NOT RETURNABLE
ITEMS NOT SHOWN
ARE BACK ORDERED

PLEASE PAY THIS AMOUNT	CONT'D
AMOUNT CREDITED	

To receive invoices and statements electronically, and/or to pay invoices online, visit Fabickcat.com and click on the ONLINE TOOLS Tab.

PLEASE DETACH AND RETURN WITH REMITTANCE WITHIN THIRTY (30) DAYS OF INVOICE DATE TO JOHN FABICK TRACTOR COMPANY, P.O. BOX 952121, ST. LOUIS, MO 63195-2121



CITY OF IRONWOOD
200 S PENOKEE RD
IRONWOOD MI 49938-3166

CUSTOMER NUMBER	
1263612	
INVOICE NUMBER	INVOICE DATE
SIMQ0009866	03-31-21
PLEASE PAY THIS AMOUNT	CONT'D
AMOUNT CREDITED	

THANK YOU FOR YOUR BUSINESS!



JFTCO Inc.
335 Hwy 41
Negaunee, MI 49866
Phone: 906-475-4191

SERVICE INVOICE

For Invoice questions please call: 636-343-5900 ext. 2970	
Invoice Number	SIMQ0009866
Invoice Date	03-31-21
AMOUNT DUE	CONT'D
Credit Amount	
Customer Order Number	36811
Customer Number	1263612

Please follow Remittance Advice in the detachable section.

SOLD TO:

102 2 SP 0.710 E0102X I0775 D7414856098 S2 P8152664 0007:0009



CITY OF IRONWOOD
200 PENOKEE RD
IRONWOOD MI 49938-3166

SHIP TO:
Marquette
US Highway 41, and Brebner Rd

NEGAUNEE, MI
49866 N71US

PSOWO NUMBER	PC	LC	MC	SHIP VIA	DOC DATE	INV. SEQ. NUMBER	SALESMAN	TERMS	STORE
MQ04778	10	10	10	WILL CALL	03-10-21	7244339	HSE	2	38
MAKE	MODEL	SERIAL NUMBER	EQUIPMENT NUMBER	METER READING	MACH. ID. NUMBER	DIV.			
AA	430D ST	0BNK06820		6504.0	039227	G			
QUANTITY	ITEM	N/R*	DESCRIPTION	UNIT PRICE	EXTENSION				
LABOR CODE BREAKDOWN:									
2	6V-3213		RING	N	6.41	12.82			
8	9R-0158		WASHER	N	2.23	17.84			
2	9R-0411		BEARING	N	26.12	52.24			
1	9R-0424		PIN	N	126.27	126.27			
2	111-4337		WASHER	N	.92	1.84			
TOTAL PARTS				SEG. 07	211.01 *				
TOTAL LABOR				SEG. 07	540.00 *				
SEGMENT 07 TOTAL					751.01 T				

REPAIR FRONT COVER/HOUSING									
TOTAL LABOR				SEG. 08	405.00 *				
SEGMENT 08 TOTAL					405.00 T				

Supply Fee					241.02 T				

ACCEPTANCE - ALL ITEMS LISTED ABOVE WILL BE DEEMED ACCEPTED BY THE CUSTOMER UNLESS WRITTEN NOTIFICATION OF CLAIMED ERRORS OR DAMAGES IS MADE TO DEALER WITHIN 5 DAYS. No merchandise can be returned without our prior approval. All returned parts are subject to our Parts Return Policy, a copy of which is available at www.fabickcat.com or upon request. TERMS: NET DUE WITHIN THIRTY (30) DAYS OF DATE OF INVOICE. 1% per month carrying charge on all past due accounts.

*- NOT RETURNABLE
ITEMS NOT SHOWN
ARE BACK ORDERED

PLEASE PAY THIS AMOUNT	CONT'D
AMOUNT CREDITED	

To receive invoices and statements electronically, and/or to pay invoices online, visit Fabickcat.com and click on the ONLINE TOOLS Tab.

PLEASE DETACH AND RETURN WITH REMITTANCE WITHIN THIRTY (30) DAYS OF INVOICE DATE TO JOHN FABICK TRACTOR COMPANY, P.O. BOX 952121, ST. LOUIS, MO 63195-2121



JFTCO Inc.
335 Hwy 41
Negaunee, MI 49866

CITY OF IRONWOOD
200 S PENOKEE RD
IRONWOOD MI 49938-3166

CUSTOMER NUMBER	
1263612	
INVOICE NUMBER	INVOICE DATE
SIMQ0009866	03-31-21
PLEASE PAY THIS AMOUNT	CONT'D
AMOUNT CREDITED	

THANK YOU FOR YOUR BUSINESS!



JFTCO Inc.
335 Hwy 41
Negaunee, MI 49866
Phone: 906-475-4191

DATE RECEIVED 4/6/21

P.O. # 36811

SIGNATURE [Signature]

APPROVED DATE 4-8-21

ACCT # 640-885-~~WAP~~

SOLD TO:

102 2 SP 0.710 E0102X I0776 D7414856098 S2 P8152664 0008:0009



CITY OF IRONWOOD
200 PENOKEE RD
IRONWOOD MI 49938-3166

* 8 pg. Inv. 933

pc 4/16/21

SERVICE INVOICE

For Invoice questions please call: 636-343-5900 ext. 2970	
Invoice Number	SIMQ0009866
Invoice Date	03-31-21
AMOUNT DUE	12365.61
Credit Amount	
Customer Order Number	36811
Customer Number	1263612

Please follow Remittance Advice in the detachable section.

SHIP TO:
Marquette
US Highway 41, and Brebner Rd

NEGAUNEE, MI
49866 N71US

PSO/WO NUMBER	PC	LC	MC	SHIP VIA	DOC DATE	INV. SEQ. NUMBER	SALESMAN	TERMS	STORE
MQ04778	10	10	10	WILL CALL	03-10-21	7244339	HSE	2	38
MAKE	MODEL	SERIAL NUMBER		EQUIPMENT NUMBER	METER READING	MACH. I.D. NUMBER		DIV.	
AA	430D ST	0BNK06820			6504.0	039227		G	
QUANTITY	ITEM	N/R*	DESCRIPTION		UNIT PRICE	EXTENSION			
SUBTOTALS BEFORE TAXES						12365.61			
<p>PLEASE BE AWARE THAT THERE IS ANOTHER COMPANY OPERATING IN WISCONSIN WITH THE FABICK FAMILY NAME. FABICK, INC. HAS BEEN OPERATING IN THE MADISON AREA SINCE 1993 AND PROVIDES PROTECTIVE COVERINGS AND SEALANTS. FABICK, INC. IS NOT AFFILIATED WITH OR ENDORSED BY FABICK CAT OR FABICK RENTS - THE CAT RENTAL STORE. PLEASE BE SURE TO REMIT PAYMENT FOR FABICK CAT AND FABICK RENTS - THE CAT RENTAL STORE INVOICES TO THE REMIT TO ADDRESS REFLECTED IN THIS INVOICE.</p>									

ACCEPTANCE - ALL ITEMS LISTED ABOVE WILL BE DEEMED ACCEPTED BY THE CUSTOMER UNLESS WRITTEN NOTIFICATION OF CLAIMED ERRORS OR DAMAGES IS MADE TO DEALER WITHIN 5 DAYS. No merchandise can be returned without our prior approval. All returned parts are subject to our Parts Return Policy, a copy of which is available at www.fabickcat.com or upon request. TERMS: NET DUE WITHIN THIRTY (30) DAYS OF DATE OF INVOICE. 1% per month carrying charge on all past due accounts.

*- NOT RETURNABLE
ITEMS NOT SHOWN
ARE BACK ORDERED

PLEASE PAY THIS AMOUNT	12365.61
AMOUNT CREDITED	

To receive invoices and statements electronically, and/or to pay invoices online, visit Fabickcat.com and click on the ONLINE TOOLS Tab.

PLEASE DETACH AND RETURN WITH REMITTANCE WITHIN THIRTY (30) DAYS OF INVOICE DATE TO JOHN FABICK TRACTOR COMPANY, P.O. BOX 952121, ST. LOUIS, MO 63195-2121



CITY OF IRONWOOD
200 S PENOKEE RD
IRONWOOD MI 49938-3166

CUSTOMER NUMBER	
1263612	
INVOICE NUMBER	INVOICE DATE
SIMQ0009866	03-31-21
PLEASE PAY THIS AMOUNT	12365.61
AMOUNT CREDITED	

THANK YOU FOR YOUR BUSINESS!

City of Ironwood
213 S. Marquette St.
Ironwood, MI 49938



IRONWOOD
MICHIGAN | *Find Your North*

Phone: (906) 932-5050
Fax: (906) 932-5745
www.cityofironwood.org

April 21, 2021

To: Ironwood City Commission

From: Bob Tervonen, City Utilities Manager 

Re: Water Utility Bill Penalty Status

During the period of March 15, 2020 to March 31, 2021, the State of Michigan had a moratorium prohibiting water service disconnection for non-payment. This moratorium expired and municipalities are in the process of disconnecting service for delinquency. City staff are working with many accounts regarding payment agreements and referring them to various funding agencies that have received additional revenue to help with various utility accounts.

The Ironwood City Commission passed a resolution to temporarily waive reconnection fees and penalties regarding monthly water bills effective March 10, 2020. Since then, the City of Ironwood has a total lost revenue of \$82,684.55 for utility penalties not charged. I am requesting your direction regarding the temporary waiving of the reconnection fees and penalties on monthly utility bills.

Thank you for your time. Please contact me if you have any questions.



This Institution is an Equal Opportunity Provider, Employer and Housing Employer/Lender



Memo

To: Mayor & City Commission

From: Scott Erickson, City Manager

CC:

Date: April 26, 2021

Re: Discuss and Consider Approving Engineering Services Agreement with Coleman Engineering to Submit a USDA Funding Application for a Phase 5 Water and Sewer Project

Introduction

With the potential for a significant federal infrastructure package being approved in Washington D.C in the next few months, it is prudent to start a funding application with USDA Rural Development for another possible phase of water/sewer projects. The funding application will allow the City of Ironwood to be “shovel ready” if/when federal infrastructure funds are made available.

Recommendation

It is recommended to approve an engineering services agreement with Coleman Engineering to submit a USDA funding application for a future Phase 5 water and sewer project



COLEMAN ENGINEERING COMPANY

CIVIL ENGINEERING • ENVIRONMENTAL ENGINEERING • GEOTECHNICAL ENGINEERING • SURVEYING

200 EAST AYER STREET • IRONWOOD, MI 49938 • PHONE: 906-932-5048

April 15, 2021

Mr. Scott Erickson, City Manager
City of Ironwood
213 S. Marquette Street
Ironwood, MI 49938

Re: Rural Development Funding Application
Phase 5 Water and Sewer Project
Gogebic County, Michigan

Dear Mr. Erickson:

Thank you for the opportunity to provide this proposal for assisting the City of Ironwood with the development of an application for funding assistance with USDA Rural Development. As we have discussed, there are likely upcoming opportunities for federal money to become available for the infrastructure stimulus bill being discussed at the federal level right now. In order to be ready to acquire that funding through USDA Rural Development, a Preliminary Engineering Report and USDA RD Application will need to be performed ahead of time in order to move quickly when the funding is available.

The Michigan Guide 2 Rural Development form details the required elements of a Rural Development application. The Michigan Guide 2 effective as of this correspondence date is incorporated into this proposal by reference and will serve as the scope of services. Separate applications will need to be submitted for the water and sewer portions of the planned project.

Rural Development's advice is to submit applications as soon as possible to "get in line" for available funds. Through the SAW sewer project and Water Asset Management projects, improvements have been identified for the next neighborhood sewer and water reconstruction project. We will need to work cooperatively together to expedite the applications and arrive at a selected project scope that is financially feasible.

Proposed Fees

CEC proposes a lump sum fee of \$10,000.00 to complete the Scope of Services described above. This includes submission of the Preliminary Engineering Report and assumes that an Environmental Report will not be necessary due to a categorical exclusion. This fee is less than what we would normally charge; however, our excellent working relationship with the City and the urgency of the timeframes compel us to expedite this work and keep costs down to a minimum level.

Acceptance

If acceptable, please execute the attached Work Order and return a signed copy to our office.

We appreciate the opportunity to submit this proposal. As always, please contact me with any questions or comments you may have.

Sincerely,

COLEMAN ENGINEERING COMPANY

A handwritten signature in cursive script, appearing to read "Paul C. Anderson".

Paul C. Anderson, P.E.
Project Manager

PCA/map

AGREEMENT NO. 07044
PROJECT NO. _____
WORK ORDER NO. _____

EXHIBIT "A"
WORK ORDER

COLEMAN ENGINEERING COMPANY and its directors, officers, shareholders, employees, agents, affiliates, independent professional associates, consultants and subcontractors, as the case may be, (collectively, "COLEMAN") agree to perform for CLIENT, on this specific Project, the Services described below. The services shall be performed subject to and upon the terms and conditions set forth in the Professional Services Agreement (the "Agreement") dated February 16, 2007, by and between COLEMAN and CLIENT, which Agreement is hereby amended to incorporate this Work Order.

It is agreed that this Agreement, and such other documents required by it during the term of this Agreement, may be approved by a signed copy transmitted by fax or .pdf copy containing all signatures in lieu of the original signed copy, and that a copy transmitted by fax or .pdf shall be legally binding upon the parties to said Agreement(s)."

PROJECT: Rural Development Funding Application
Phase 5 Water and Sewer Project
Gogebic County, Michigan

SERVICES: As described in our proposal letter dated April 15, 2021, a copy of which is attached and made part of this contract.

FEES: Services will be completed for a lump sum amount of \$10,000.00, for the scope of work and in accordance with the assumptions and conditions set forth in our proposal letter dated April 15, 2021, a copy of which is attached and made part of this contract.

SPECIAL TERMS AND CONDITIONS:

During completion of this work, Coleman Engineering Company will not accept responsibility for the safety of individuals other than Coleman Engineering Company employees.

AUTHORIZATION

This Work Order and the scope of services (the "Services") defined herein are approved and COLEMAN is hereby directed and authorized to proceed with the Services for the designated Project in accordance with the terms and conditions of the above-referenced Agreement.

Requested By:

Accepted By:

CITY OF IRONWOOD

COLEMAN ENGINEERING COMPANY



By: Scott Erickson

By: Paul C. Anderson, P.E.

Title: City Manager

Title: Project Manager

Date: _____

Date: April 15, 2021

BID TABULATION SHEET

Name of Bidder:

Penchura					\$24,135.00
Lee Recreation, LLC					\$20,950.00
Play Environments Design					\$25,172.00
Miracle Recreation Equipment, Inc.					\$24,251.00
Sinclair Recreation					\$23,944.43

Witnesses to Bid Opening:

Bid Award Action Taken

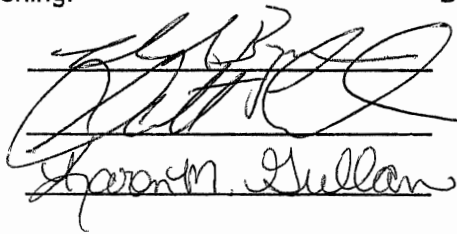
 Sharon M. Sullivan



The City of
IRONWOOD

Department of Public Safety

123 West McLeod Avenue Ironwood, Michigan 49938

PHONE: 906-932-1234

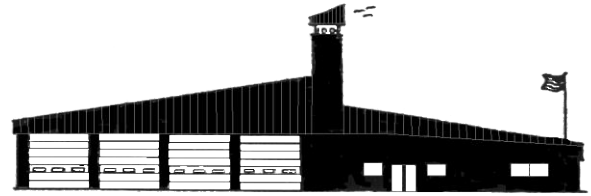

Andrew DiGiorgio

Director of Public Safety

DATE: April 22, 2021

TO: Ironwood City Commission

SUBJECT: Adopt Guidelines Allowing PSO Rimkus to Obtain his Department Issued Service / Duty Weapon upon Retirement

RECOMMENDATION:

It is my recommendation that the City Commission authorize the Director of Public Safety to allow PSO Rimkus to obtain his duty weapon upon honorably retiring in good standing.

BACKGROUND:

PSO Michael Rimkus has notified the city that he will be retiring in June 2021. PSO Rimkus has been a member in good standing with the Department for 25 years. The public interest will continue to be served by strengthening the retiree's community bond and commitment by rewarding his years of faithful service. In addition, the retention of the weapon by honorably retired officers will continue to serve as a deterrent to criminal activity in our community.

FISCAL:

The purchase of the weapon will be made by the Ironwood Professional Police Association in the amount of \$1.00.

Memo

To: Mayor & City Commission

From: Scott Erickson, City Manager

CC:

Date: April 26, 2021

Re: Discuss and Consider “No Parking” Traffic Control Order and Pavement Striping Status on Norrie Street between Lowell Street and Hemlock Street

Introduction

The Ironwood City Commission recently discussed the existing “No Parking” designation on the south side of Norrie Street between Lowell Street and Hemlock Street and the location of the centerline stripe in relation to the currently permitted parking along the north side of the street.

Upon reviewing the Manual on Uniform Traffic Control Devices (MUTCD) and standards for driving lane widths for collector streets, such as Norrie Street, the following has been determined:

1. The pavement width necessary to designate “on-street” parking for Norrie Street would require a pavement width of 31 ft to allow for two 11 ft lanes and one 9 ft parking lane. The current pavement width of Norrie Street is 28.5 ft.
2. The current centerline location on Norrie Street provides for a 15 ft. wide west bound lane and a 13.5 ft east bound lane. If the centerline striping were to be shifted further to the south this would provide for an 11 ft east bound lane (no parking on the south side) and a 17.5 ft

west bound lane (which would provide for a 6.5 ft parking lane, which is 2.5 ft short of the required 9 ft. lane)

3. Based on street design standards, Norrie Street does not have enough width to properly establish a designated parking area along the north side of the street.

Options to Consider:

1. Designate this section of Norrie Street as No Parking both sides.
2. Remove No Parking Designation
3. Leave as is
4. Move Centerline stripe 2.5 ft to the south per original striping layout
5. Other

TRAFFIC CONTROL ORDER NO. 18

Pursuant to the provisions of the Uniform Traffic Code for cities, townships and villages as adopted by the City of Ironwood, Chapter 126 of the Ironwood City Code, in particular Sections 2.53 and 2.33 of said Code, as well as all other applicable sections of said Code, the following traffic control order is hereby issued:

No parking at any time on the north side of Sutherland Street.

No parking at any time on either side of Lowell Street
between Frederick Street and Cloverland Drive. *

* No parking at any time on the south side of Norrie Street. *

No parking at any time on the north side of Arch Street
between Frederick Street and Lawrence Street.

No parking at any time on the south side of Ridge Street
between Lowell Street and Lawrence Street.

No parking at any time on the east side of Marquette Street
between McLeod Avenue and Vaughn Street.

No parking at any time on the east side of Curry Street
between Vaughn Street and the High School parking lot.

* No parking at any time on the south side of Burt Street
300 feet either side of Dr. Gallo's Clinic.

No parking at any time on the south side of Oak Street
between Balsam Street and Hazel Street.

No parking at any time on the west side of Ashland Court.

No parking at any time on the south side of Gogebic Street
between Douglas Boulevard and Lawrence Street.

THERE SHALL BE NO PARKING AT ANY TIME ON THE FOLLOWING STREETS
DURING THE PERIOD FROM NOVEMBER 1 TO MAY 1:

~~The north side of Ayer Street between Lake Street and
Marquette Street.~~

~~The north side of Ayer Street between Lawrence Street and
Hemlock Street.~~

~~The south side of McLeod Avenue between Marquette Street
and Lake Street.~~

CURRENT NORRIE STREET

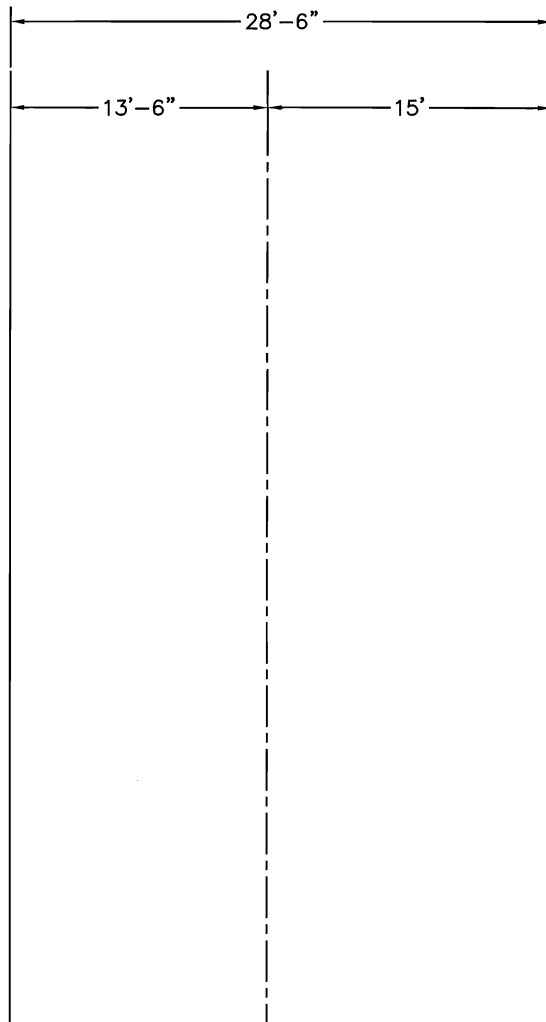

REQUIRED WIDTH FOR "DESIGNATED"
ON-STREET PARKING

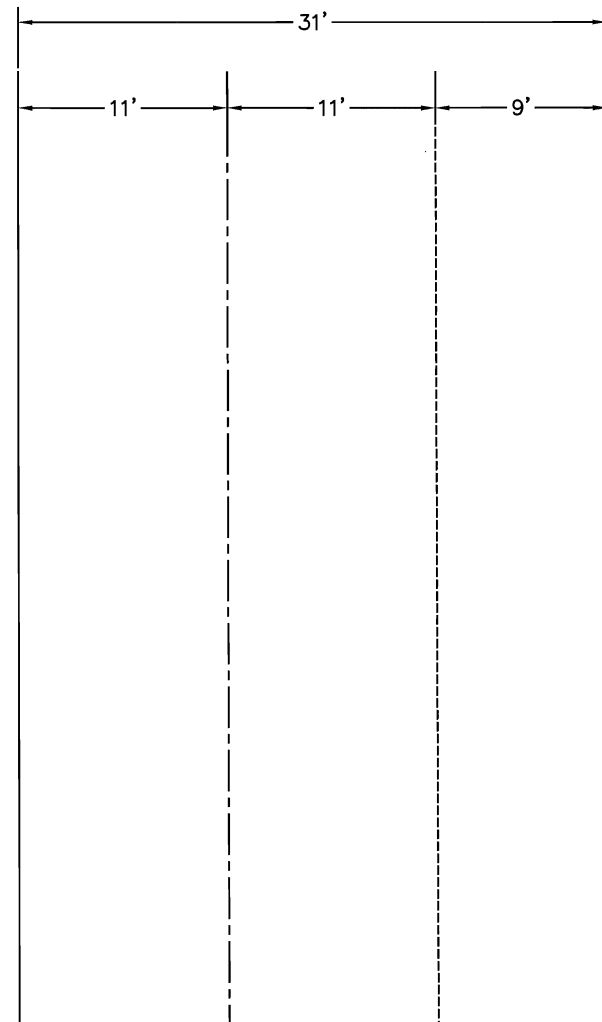

IRONWOOD
MICHIGAN | *Find Your North*

213 S. MARQUETTE ST.
IRONWOOD, MI 49938
PH: (906) 932-5050
FAX: (906) 932-5745

TITLE:

NORRIE STREET PARKING

REVISION: A

DRAWN BY: J. ALONEN

DRAWING NO.

DATE: 4/20/2021

APPROVAL BY: S. ERICKSON

S-1

Memo

To: Mayor & City Commission

From: Scott Erickson, City Manager

CC:

Date: April 26, 2021

Re: Discuss and Consider Existing City/County Ordinance(s) to Manage the Number of Dogs/Cats allowed at a Residence in the City of Ironwood.

Introduction

The Ironwood City Commission recently discussed what controls are currently in-place to manage the number of dogs/cats that are allowed in a residence in the City of Ironwood. There are two local controlling entities, the City of Ironwood and Gogebic County, that have regulatory authority regarding animal control, including dogs. Gogebic County has an animal control enforcement ordinance (also establishing an animal control officer) and the City of Ironwood has ordinance controls identified in City Ordinance Chapter 6 – Animals, Article II. Dogs/Cats and Zoning Ordinance Section 34-224(d) Prohibited Home Occupations (Kennels). Both ordinances provide direction on the management of “kennels” and other related animal nuisances but do not provide for specific limitations on the number of domestic pets that can be kept at a residence.

If the City Commission would want to consider establishing a specific limitation on the number of domestic animals that could be kept at a residence in the City of Ironwood, additional research and proposed ordinance language could be developed.

City of Ironwood
213 S. Marquette St.
Ironwood, MI 49938



IRONWOOD
MICHIGAN | *Find Your North*

Phone: (906) 932-5050
Fax: (906) 932-5745
www.cityofironwood.org

April 19, 2021

MEMO

TO: Scott Erickson, Ironwood City Commission
FROM: Bob Richards, DPW Supervisor
RE: Authorization to seek information and bids for new Asphalt Hot Box

Department of Public Works is requesting your authorization to seek information and bids for a new Asphalt Hot Box.

The purchase would allow our City Street crew to keep and maintain the proper temperature for asphalt and cold patch during the process of pot hole repairs mill/overlays. The proceeds for this purchase would come from the Equipment Fund.

Robert Richards
DPW Supervisor

Date



This Institution is an Equal Opportunity Provider, Employer and Housing Employer/Lender





2601 WEST SUPERIOR ST
 DULUTH MN 55806-1836
 Phone: 218-529-2110
 Fax: 218-722-0235

To: CITY OF IRONWOOD
 213 S MARQUETTE ST
 IRONWOOD MI 49938
 Attn: Mara Maher
 Phone: 906-932-5050
 Fax: 906-932-0263
 Email: joseph.hagen@graybar.com

Date: 04/20/2021
Proj Name: STREET LIGHT
GB Quote #: 0237770873
 Release Nbr:
 Purchase Order Nbr: STREET LIGHT
 Additional Ref#
 Valid From: 04/20/2021
 Valid To: 05/20/2021
 Contact: Joseph Hagen
 Email: joseph.hagen@graybar.com

Proposal

We Appreciate Your Request and Take Pleasure in Responding As Follows

Item	Item/Type	Quantity	Supplier	Catalog Nbr	Description	Price	Unit	Ext.Price
100		1 EA	STERNBERG	PT-B780-5P- VCOB-4L40TS- MDL05- A/6216FP5	PT-B780-5P-VCOB- 4L40TS-MDL05- A/6216FP5-.BK	\$5,037.94	1	\$5,037.94
200		1 EA		OUTBOUND FREIGHT		\$210.00	1	\$210.00

Total in USD (Tax not included): \$5,247.94

This equipment and associated installation charges may be financed for a low monthly payment through Graybar Financial Services (subject to credit approval). For more information call 1-800-241-7408 to speak with a leasing specialist.

To learn more about Graybar, visit our website at www.graybar.com 24-Hour Emergency Phone#: 1-800-GRAYBAR

Subject to the standard terms and conditions set forth in this document. Unless otherwise noted, freight terms are F.O.B. shipping point prepaid and bill. Unless noted the estimated ship date will be determined at the time of order placement.

ACCESS DOOR
GFI-LPIUC
PLANTER ARM

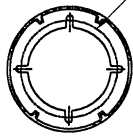

14" DIA. BC, DIAMOND PATTERN
(4) 3/4" X 18" BOLTS

STREET SIDE
DUAL FLAG HOLDER
BANNER ARMS

LED SOURCE
4L40TS-MDL05
4 LED'S,
75w, 4,000K
SYMMETRIC DISTRIBUTION

ACRYLIC ACORN

DRIVER COMPARTMENT

DUAL FLAGHOLDER

THE 1" DIA. BREAKAWAY
BANNER ARMS ARE 37" APART
FROM THE TOP OF THE UPPER
ARM, TO THE BOTTOM OF THE
LOWER ARM

BANNER ARMS SET FOR
18" X 36" BANNERS

BANNERS BY OTHERS

DESIGNED TO BREAK AT 60 MPH
WIND SPEED

SINGLE HOOKED PLANTER
ARM 40LB MAX

LOW PROFILE DUPLEX
GFI RECEPTACLE WITH
IN USE COVER

5" DIA. FLUTED ALUMINUM POLE
.250 WALL THICKNESS

POLE WELDED FOR SINGLE
UNIT CONSTRUCTION

ACCESS DOOR

18" DIA. BASE, 1" FLOOR THICKNESS
FOUR ANCHOR BOLTS

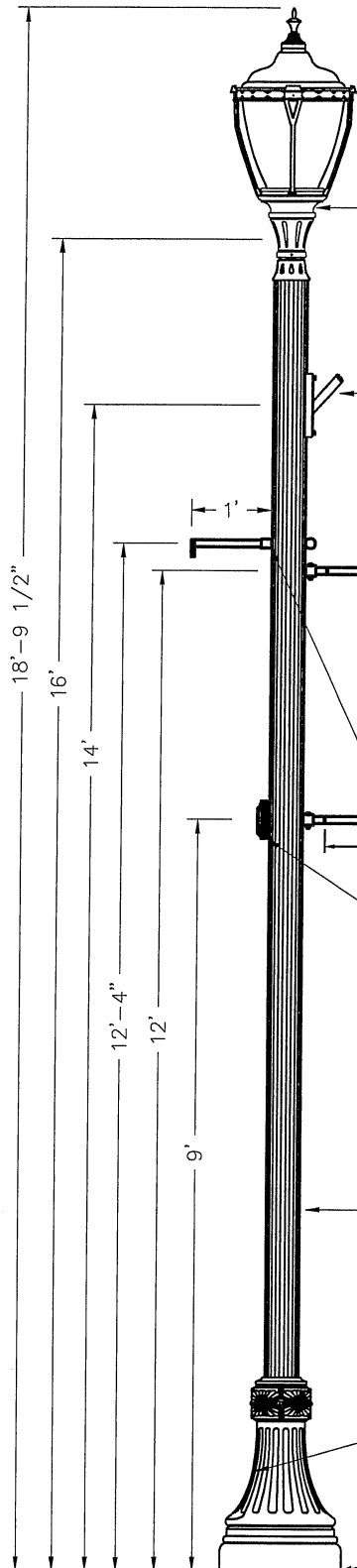

REV	REVISIONS	DATE	RVSD	IRONWOOD, MI	DRAWING NUMBER
A	ORIGINAL			IRONWOOD, MI	JG
B	ADDED PLANTER ARM, CHANGED BANNER ARMS STYLE AND GFI STYLE	6/12/20	JG	PT-B780-5P-VC0B-4L40TS-MDL05-A/6216FP5-.250/GFI LPIUC/DUAL-FH/	
C	CHANGED PLANTER ARM LOCATION PER REQUEST	6/12/20	JG	BDBA6/SHPA/BK	
				POLE HEIGHTS HAVE A TOLERANCE OF + OR - 2"	SC35337
				StembergLighting ESTABLISHED 1929 / EMPLOYEE OWNED	

City of Ironwood
213 S. Marquette St.
Ironwood, MI 49938



IRONWOOD

MICHIGAN | *Find Your North*

Phone: (906) 932-5050
Fax: (906) 932-5745
www.cityofironwood.org

April 21, 2021

MEMO

TO: Ironwood City Commission

FROM: Bob Richards, DPW Supervisor

RE: Repairs to Highlift Booster Pump #1

February 3, 2021 at approximately 8:00 p.m., the City Water Facilities Coordinator was alerted of low water system pressure. It was discovered that the lower bearing of the electric pump motor in Highlift Booster Pump #1 had released from the lower housing. This was causing water leakage and damage to the pump.

The repairs to Highlift booster #1 were determined to be urgent for factors of fire protection, flushing and possible large water main leaks. Booster Pump #1 is necessary to give the City the needed water during these unforeseen events.

Kleiman Pump and Well Drilling, Inc. was contacted to perform emergency repairs on the pump, as they are the sole service provider for the City's highlift booster pumps. It is recommended to approve payment for the repairs in the amount of \$17,047.24.



This Institution is an Equal Opportunity Provider, Employer and Housing Employer/Lender





Phone: (906) 774-1955
 Toll Free: (800) 672-7201
 email: info@kleimanwater.com

Water

INVOICE

P.O. Box 704
 Iron Mountain, MI 49801-0704

DATE	INVOICE NO.
3/15/2021	21-126

BILL TO:

CITY OF IRONWOOD
 213 SOUTH MARQUETTE
 IRONWOOD, MI 49938

DATE RECEIVED 2/17/21
 P.O. # N/A - Service call
 SIGNATURE [Signature]
 APPROVED DATE 4-21-21
 ACCT # 675-551-801

JOB DESCRIPTION:

#1 HIGHLIFT BOOSTER
 REPLACED PUMP & HAD MOTOR
 REPAIRED BY L & S ELECTRIC

Customer Phone	P.O. #	TERMS	DUE DATE	JOB NUMBER
906-932-5050		Net 30	4/14/2021	B117-21

QTY	DESCRIPTION	RATE	AMOUNT
4.5	02/08/21 LOAD/PREP FOR PUMP/MOTOR REMOVAL BY 44-60 HOUR/S TWO MEN SHOP TIME	140.00	630.00
9.25	02/09/21 PUMP/MOTOR REMOVAL BY 44-60 HOUR LABOR 2 MEN - INDUSTRIAL	190.00	1,757.50
9.25	HOURS 5TH WHEEL TRUCK	25.00	231.25
1	DAY PER DIEM-2 MEN	360.00	360.00
6	02/10/21 PUMP/MOTOR REMOVAL BY 44-60 HOUR LABOR 2 MEN - INDUSTRIAL	190.00	1,140.00
6	HOURS 5TH WHEEL TRUCK	25.00	150.00
8	02/11/20 SHOP TIME BY 44-60 CLEANED UP SHAFTS, FLANGES, PACKING GLAND, DISCHARGE HEAD, SPACER AND OTHER PARTS THAT WERE FULL OF GREASE. PUSHED BUSHING OUT OF PACKING GLAND. BROUGHT SHAFT TO MACHINE SHOP. STEAMED OFF AS MUCH GREASE AS POSSIBLE FROM UPPER PIECES. CUT NEW GASKET FOR PACKING GLAND. MACHINED 8" FLANGE FOR NEW PUMP INTAKE. HOUR/S ONE MAN SHOP TIME - 60	70.00	560.00

THANK YOU FOR YOUR BUSINESS!

- PAYMENT DUE IN FULL WITHIN 10 DAYS OF INVOICE DATE.
- 1.5% PER MONTH CARRYING CHARGE AFTER 10 DAYS.
- VISA / MASTERCARD ACCEPTED
- NO RETURNS ON PARTS AFTER 10 DAYS, SPECIAL ORDER ITEMS OR ON ELECTRICAL PARTS / COMPONENTS.
- NSF CHECKS WILL BE CHARGED A \$35.00 FEE.

Total:

Payments/Credits:

Balance Due:



Phone: (906) 774-1955
 Toll Free: (800) 672-7201
 email: info@kleimanwater.com

INVOICE

P.O. Box 704
 Iron Mountain, MI 49801-0704

DATE	INVOICE NO.
3/15/2021	21-126

BILL TO:
CITY OF IRONWOOD 213 SOUTH MARQUETTE IRONWOOD, MI 49938

JOB DESCRIPTION:
#1 HIGHLIFT BOOSTER REPLACED PUMP & HAD MOTOR REPAIRED BY L & S ELECTRIC

Customer Phone	P.O. #	TERMS	DUE DATE	JOB NUMBER
906-932-5050		Net 30	4/14/2021	B117-21
QTY	DESCRIPTION	RATE	AMOUNT	
4	HOUR/S ONE MAN SHOP TIME - 44	70.00	280.00	
	02/25/21 INSTALLED PUMP/MOTOR BY 44-60			
10.25	HOUR LABOR 2 MEN - INDUSTRIAL	190.00	1,947.50	
10.25	HOURS 5TH WHEEL TRUCK	25.00	256.25	
1	DAY PER DIEM-2 MEN	360.00	360.00	
	02/26/21 INSTALLED PUMP/MOTOR BY 44-60			
1	BRASS SLEEVE BEARING FOR 1-1/2" DIA. SHAFT, 2" HOUSING, 3-1/2" LONG	54.48	54.48	
1	REBUILT MOTOR BY L&S ELECTRIC	6,307.96	6,307.96	
1	FLANGE GASKET 8" RUBBER	4.21	4.21	
1	3/4" X 3-1/2" S/S BOLTS & NUTS - EIGHT OF EACH	40.15	40.15	
1	FLANGE 8" SLIP ON	62.12	62.12	
1	8" MPT X WELD NIPPLE - 6" LONG	251.60	251.60	
12	5/8" - 11 X 2" GRADE 8 BOLTS	1.69	20.28	
1	ROMAC XR501-6.28 X 7.60 X 7 COUPLING EPOXY COATED	375.45	375.45	
1	TUBE OF PERMATEX GASKET MAKER - 1 MIN. GASKET MAKER	12.99	12.99	
1	SHAFT THAT WAS MADE BY LOCAL MACHINE SHOP	634.20	634.20	
1	BLACK 1-1/2" LINESHAFT COUPLING	40.05	40.05	

THANK YOU FOR YOUR BUSINESS!

- PAYMENT DUE IN FULL WITHIN 10 DAYS OF INVOICE DATE.
 - 1.5% PER MONTH CARRYING CHARGE AFTER 10 DAYS.
 - VISA / MASTERCARD ACCEPTED
 - NO RETURNS ON PARTS AFTER 10 DAYS, SPECIAL ORDER ITEMS
 OR ON ELECTRICAL PARTS / COMPONENTS.
 - NSF CHECKS WILL BE CHARGED A \$35.00 FEE.

Total:
Payments/Credits:
Balance Due:

Please like us and share
 your experience with us on
 Facebook!



Phone: (906) 774-1955
 Toll Free: (800) 672-7201
 email: info@kleimanwater.com

INVOICE

P.O. Box 704
 Iron Mountain, MI 49801-0704

DATE	INVOICE NO.
3/15/2021	21-126

BILL TO:
CITY OF IRONWOOD 213 SOUTH MARQUETTE IRONWOOD, MI 49938

JOB DESCRIPTION:
#1 HIGHLIFT BOOSTER REPLACED PUMP & HAD MOTOR REPAIRED BY L & S ELECTRIC

Customer Phone	P.O. #	TERMS	DUE DATE	JOB NUMBER
906-932-5050		Net 30	4/14/2021	B117-21
QTY	DESCRIPTION	RATE	AMOUNT	
1.67	FEET OF 5/8" GRAPHITE PACKING	10.21	17.05	
8	5/8" - 11 X 1.5" GRADE 8 BOLTS	1.45	11.60	
1	36" X 3/4" - 10 THREADED ROD	16.31	16.31	
1	6" FULL FACE HIGH PRESSURE FLANGE GASKET	7.92	7.92	
4	3/4" - 10 GRADE 8 NUTS	0.85	3.40	
3	ELECTRICAL MULTIWAY TAP/SPLICE	21.24	63.72	
6.75	HOUR LABOR 2 MEN - INDUSTRIAL	190.00	1,282.50	
6.75	HOURS 5TH WHEEL TRUCK	25.00	168.75	

THANK YOU FOR YOUR BUSINESS!	Total: \$17,047.24
<ul style="list-style-type: none"> - PAYMENT DUE IN FULL WITHIN 10 DAYS OF INVOICE DATE. - 1.5% PER MONTH CARRYING CHARGE AFTER 10 DAYS. - VISA / MASTERCARD ACCEPTED - NO RETURNS ON PARTS AFTER 10 DAYS, SPECIAL ORDER ITEMS OR ON ELECTRICAL PARTS / COMPONENTS. - NSF CHECKS WILL BE CHARGED A \$35.00 FEE. 	Payments/Credits: \$0.00
Balance Due: \$17,047.24	

Please like us and share
 your experience with us on
 Facebook!